

B I P T

**BELGIAN INSTITUTE FOR POSTAL SERVICES AND
TELECOMMUNICATION.**

**COMMUNICATION OF THE BIPT OF 17 JANUARY 2012 CONTAINING
GUIDELINES FOR INFRASTRUCTURE SHARING.**

Belgian Institute for Postal Services and Telecommunications

BIPT - Ellipse Building - Building C - Boulevard du Roi Albert II 35 - 1030 Brussels

Tel. 02 226 88 88

Fax 02 226 88 77

<http://www.bipt.be>

Table of Contents

0	Glossary	1
1	Introduction	2
2	Mobile infrastructure sharing architecture	3
2.1	Passive network sharing	4
2.2	Active network sharing	5
2.3	Deeper sharing or integration	8
3	Legal situation	10
3.1	EU law	10
3.2	Belgian law	14
4	Main operational impact and pros and cons of mobile infrastructure sharing	17
4.1	Main operational impacts	17
4.2	Pros and cons of RAN sharing	18
5	Conclusions/Guidelines	23

0 Glossary

3GPP	3rd Generation Partnership Project
CFI	European Court of First Instance
CPICH	Common pilot Channel
GMSC	Gateway MSC
GWCN	Gateway core network
HLR	Home location register
HSPA	High-speed Packet Access
HSS	Home subscriber service
LTE	Long Term Evolution
MHz	Megahertz
MME	Mobility management entity
MOCN	Multi-operator core network
MORAN	Multi-operator RAN
MSC	Mobile switching centre
NOC	Network operations centre
NRA	National regulatory authority
PA	Power amplifier
PDN GW	Packet data network gateway
RAN	Radio access network
RNC	Radio network controller
RSPG	Radio Spectrum Policy Group
RSPP	Radio spectrum policy programme
SGSN	Serving GPRS support node
SGW	Serving gateway
SIM	Subscriber identity module
SMP	Significant market power
TRX	Transceiver
UMTS	Universal Mobile Telecommunications System
VLR	Visitor location register

1 Introduction

Mobile infrastructure and in particular radio access network (RAN) sharing is becoming an important topic that mobile network operators are evaluating and considering in their expansion plans and investments decisions.

In this context, in order to ensure full transparency for all market players, the BIPT decided to issue this document to clarify the main concepts associated with mobile infrastructure sharing, to outline its pros and cons, and to provide guidelines and expectations about operator behaviour in the Belgian market. It is important to note that agreements with MVNO/Full MVNO are not envisaged by the communication. The purpose of the document is to focus on infrastructure sharing between MNOs. These guidelines are related to network sharing between MNOs only.

These guidelines have been prepared by taking into account:

- European best practice and feedback from previous experiences related to mobile infrastructure sharing
- the legal situation in Europe and Belgium in relation to mobile infrastructure sharing
- general objectives of the regulatory framework

The remainder of this document is laid out as follows:

- Section 2 describes different types of architecture for mobile infrastructure sharing
- Section 3 presents the European and Belgian legal situation in relation to mobile infrastructure sharing
- Section 4 summarises the main operational impact and the pros and cons of mobile infrastructure sharing
- Section 5 presents BIPT's guidelines on mobile infrastructure sharing.

Only the provisions of the law on electronic communications and the applicable Royal Decrees (3G, 4G, spectrum trading) are legally binding. The present document presents BIPT's current interpretation of the rules, and this interpretation is subject to potentially different interpretation by courts. Only the interpretation of the courts is definitive and binding on operators. The BIPT encourages ex ante communication of infrastructure sharing plans in order to help enhance legal certainty for operators when they embark on infrastructure sharing plans.

2 Mobile infrastructure sharing architecture

In this section, we describe the different types of architecture used for mobile infrastructure sharing. Mobile infrastructure sharing can take many forms, but the main architectures can be grouped into the following three categories according to the depth of the sharing agreement:

1. passive network sharing – operators agree to share passive parts of a mobile network
2. active network sharing – this extends passive network sharing to include some active access equipment and, potentially, spectrum sharing
3. deeper sharing or integration – operators share parts of the core network in addition to the RAN, which is also referred to as gateway core network configuration (GWCN).

The main types of infrastructure sharing are presented in Figure 2.1 below.

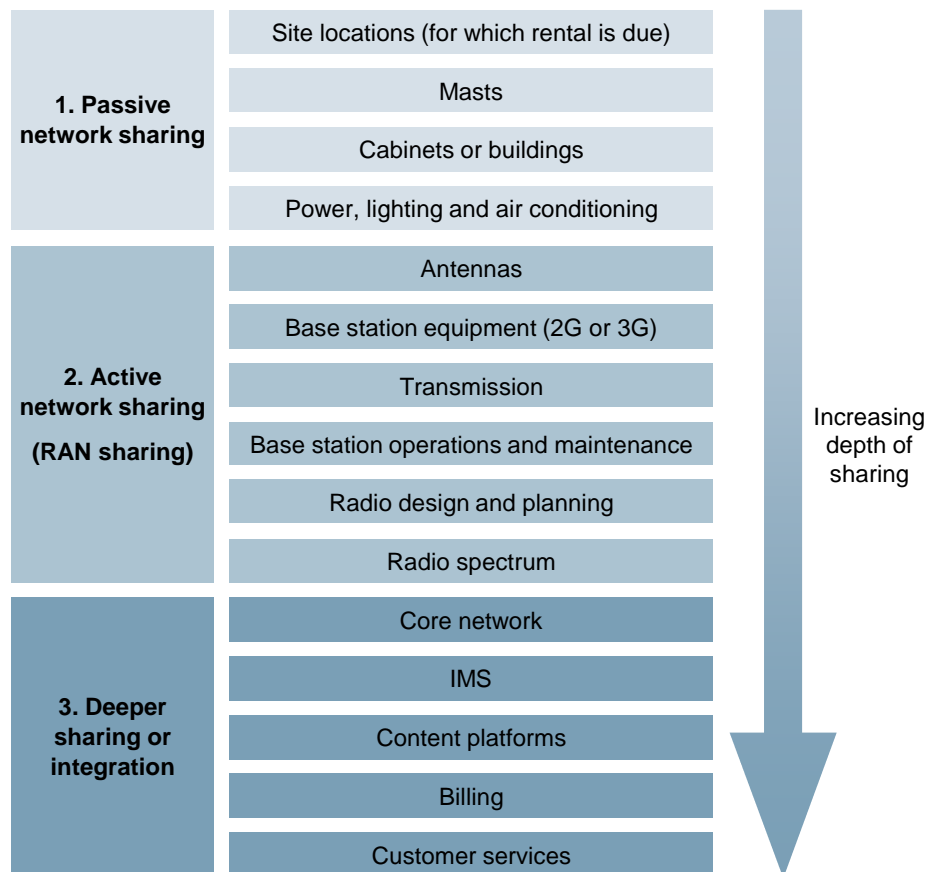

Figure 2.1: Types of infrastructure sharing by network elements to be shared [Source: Analysys Mason]

These three categories are further discussed in the following sub-sections, mainly in the context of 3G, for which we have historical data, but also in the context of emerging 4G technologies.

2.1 Passive network sharing

Passive network sharing refers to the sharing of the passive parts of a mobile network, including:

- physical space, such as the cell-site compound, masts, towers or rooftops, cabinets or shelters
- passive technical facilities, such as air conditioning, power supply, battery back-up, and alarm installation
- other cell-site services, such as security.

Passive network sharing is the most common form of wireless network infrastructure co-operation and is supported and incentivised in most countries from a regulatory standpoint. Agreements vary widely in scope, from simple site sharing (that is, sharing just the compound) to a more-comprehensive sharing of site facilities (see Figure 2.2 below). Tower companies have emerged in some countries as neutral third parties that specialise in providing a range of facilities and site sharing services to multiple operators.

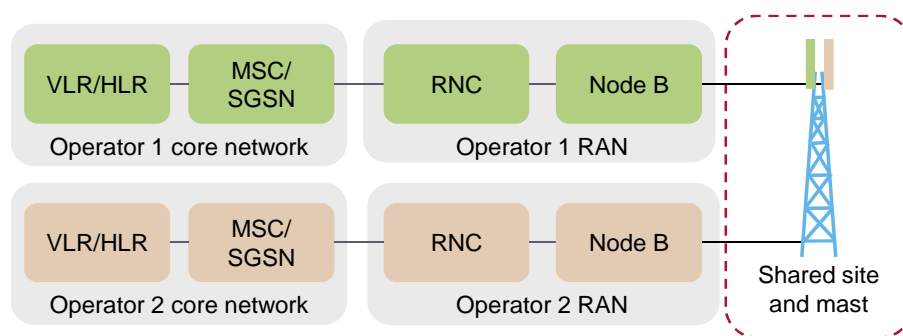

Figure 2.2: *Passive network sharing configuration [Source: Analysys Mason]*

Several operators are using passive network sharing such as Vodafone and Telefonica/O2 in the UK, Spain, Germany and Ireland; Vodafone and TIM in Italy.

The present legal system in Belgium does not work optimally for a new entrant until this operator also has some sites to offer. The operator would however be able to use national roaming whenever he reaches 20% coverage by its own infrastructure. This is a common rule that has been used by regulators in different countries and is not the subject of this document. A new entrant can nevertheless use infrastructure sharing even if he does not yet own sites on commercial basis with existing operators. In the absence of regulatory intervention and specific legislation, passive sharing requires the agreement of the host operator.

2.2 Active network sharing

Active network sharing can be split into three main types:

- basic RAN sharing, including antennas, feeder cable and transmission links
- multi-operator RAN (MORAN), in which the radio network controller (RNC) and parts of the Node B are logically partitioned between the sharing parties
- multi-operator core network (MOCN), where the operators share the RNC and Node B and pool their frequencies.

2.2.1 Basic RAN sharing

Passive network sharing can be extended to include some active equipment, such as antennas, feeder cables and transmission links (see Figure 2.3 below). These more comprehensive forms of sharing increase cost savings. Antenna sharing is technically feasible, but may be challenging if operators use different frequencies or have different network optimisation strategies. Using advanced antenna solutions may partially mitigate these issues. Feeder sharing is feasible, but results in power loss and hence reduces coverage. Operators may be able to share transmission (backhaul) between the Node B and RNC, based on T1/E1 leased lines, fibre, Ethernet, microwave or satellite. However, the following characteristics of backhaul sharing should be considered, as it:

- requires a combiner and diplexer at each end of each transmission link
- reduces opex for leased lines and for microwave spectrum fees
- is not always permitted by regulators as sharing is sometimes limited to specific areas (for example, in rural areas).

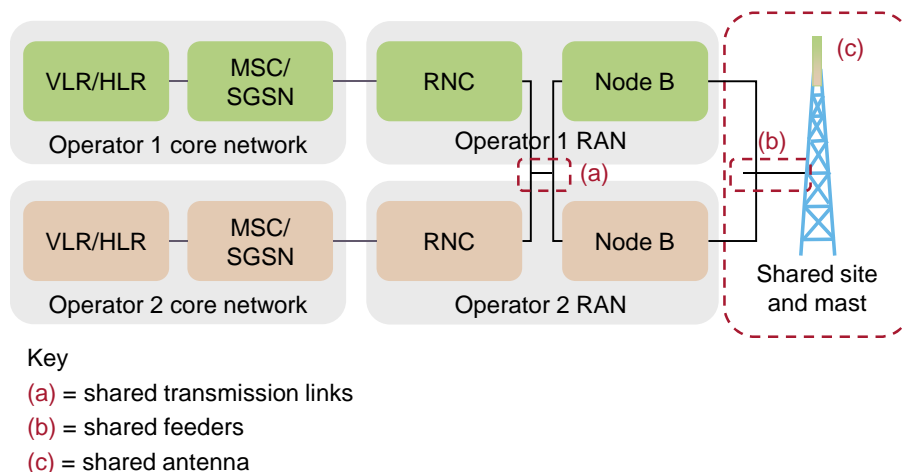

Figure 2.3: Basic RAN sharing configuration [Source: Analysys Mason]

Several worldwide operators are using basic RAN sharing.

2.2.2 Multi-operator RAN

Nokia Siemens Network launched the first MORAN solution in May 2001, but other vendors (including Ericsson and Huawei) now support this type of configuration. In this architecture, the RNC and parts of the Node B are logically partitioned between the sharing parties (see Figure 2.4 below). There are common site-level parameters, such as the antenna downtilt which is used to lower interference problems, but the operators can independently control cell-level parameters, such as the Common Pilot Channel (CPICH) which is used in the Scrambling Coding Identification phase to complete the synchronization of the W-CDMA mobile phone to the Node B. These independent cell-level parameters minimises the effect of sharing on service and coverage differentiation. If operators share the same location, there will be only small differences in the coverage. The differentiation in service provision is more related to the pricing, customer service, quality of service and policing rather than to coverage differentiation.

In the Node B, the radio and power amplifiers remain physically independent, to allow the operators to use their assigned frequencies. MORAN is device-independent, and does not require any device support to display the correct operator logo on screen. Operators also can have dedicated RANs outside the shared RAN area.

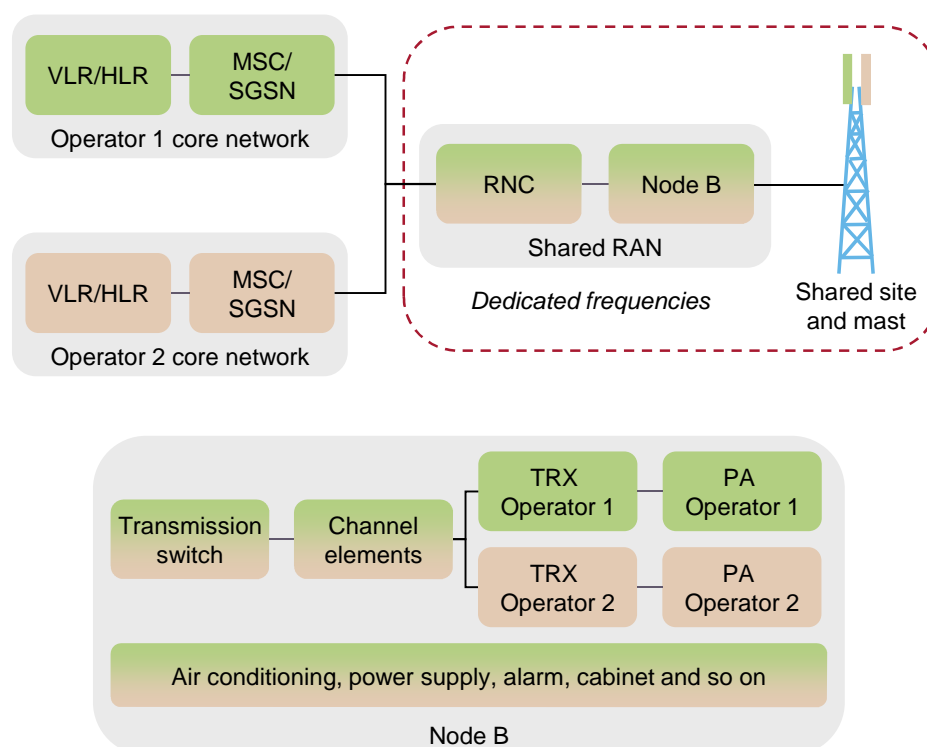

Figure 2.4: MORAN sharing configuration [Source: Analysys Mason]

The MORAN architecture is for example used in Australia and in the UK.

2.2.3 Multi-operator core network

MOCN is an active RAN-sharing solution specified in 3GPP Release 6. In this solution, operators share both the RNC and Node B and pool their frequencies (see Figure 2.5 below). Common site and cell-level parameters limit the scope for service differentiation. MOCN may be suitable where there is insufficient spectrum for operators to deploy independent carriers. Spectrum sharing (also referred to as spectrum pooling) is not permitted under many regulatory regimes, due to concern that it would limit operators' independence and would raise issues regarding the entity being awarded the spectrum not being the entity using it in practice. MOCN is device-dependent, requiring 3GPP Release 6 devices to display individual operator logos. Again, operators can have dedicated RANs outside the shared RAN area.

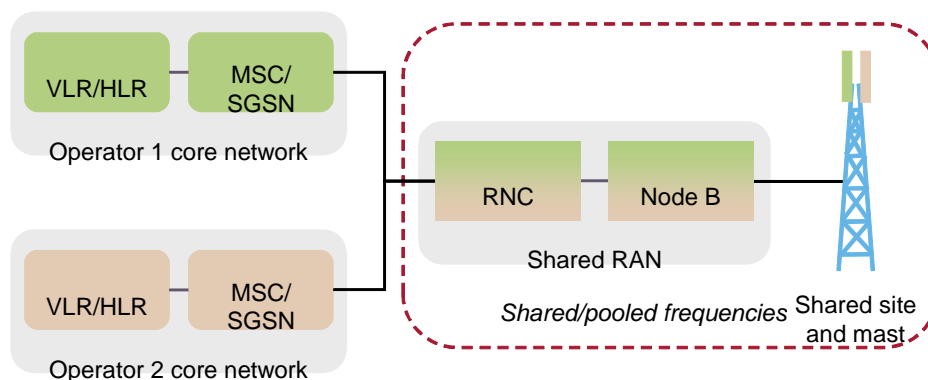

Figure 2.5: MOCN sharing configuration [Source: Analysys Mason]

Canadian operators Bell and TELUS are using MOCN for HSPA network sharing, while 3GIS in Sweden is migrating from a GWCN arrangement to MOCN.

2.2.4 MORAN and MOCN in the context of an LTE network

MORAN and MOCN configurations can also be applied to Long Term Evolution (LTE) technology. LTE introduces an all-IP architecture and a reduced number of network nodes. It is standardised in 3GPP Releases 8 and 9. The RAN consists of a single node, the eNode B. It differs from the UMTS RAN in that there is no RNC, as the functions of the RNC have largely been incorporated into the eNode B. The eNode B connects to the core network via the S1 interface. In the context of network sharing, this enables each eNode B to be connected to multiple core networks. The core network comprises the following three elements (see Figure 2.6 below).

- The mobility management entity (MME): this is the main control node for the LTE RAN and manages mobility between the LTE and 2G/3G RANs. It is also responsible for user authentication, via interaction with the home subscriber server (HSS).

spectrum of one of the sharing parties. There is a shared gateway core, comprising the GMSC, SGSN and VLR, which connects to the sharing operators' individual core networks. Network sharing is implemented using the roaming features in the core network. A SIM-based solution enables devices to identify and display the name and logo of the serving operator.

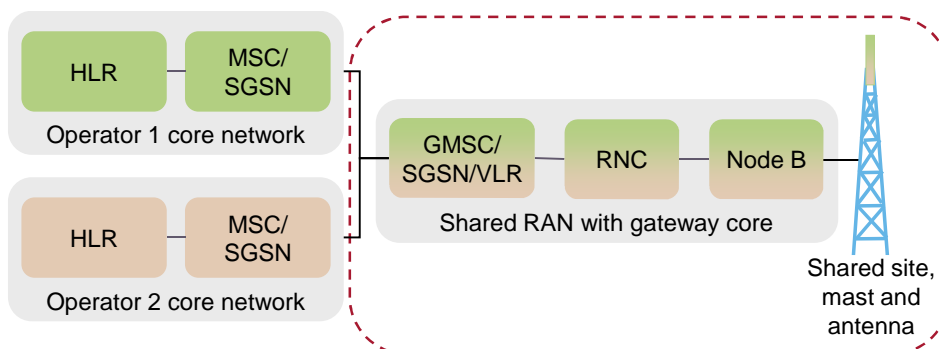

Figure 2.8: GWCN sharing configuration [Source: Analysys Mason]

A GWCN configuration is also possible for an LTE network (see Figure 2.9 below). In this case, the operators share the MME in addition to the eNode B. The user device informs the eNode B of the selected core network operator, and the eNode B relays this information to the MME, to ensure the correct operator name is displayed. This arrangement is supported in the LTE standards (3GPP Release 8).

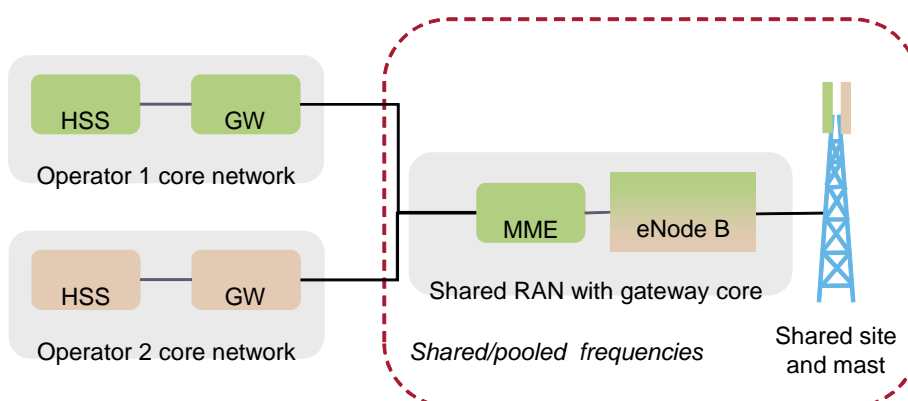

Figure 2.9: GWCN sharing configuration for an LTE network [Source: Analysys Mason]

3GIS in Sweden is the only operator that uses GWCN, but it announced in 2009 that it is migrating to MOCN.

3 Legal situation

This section considers mobile infrastructure sharing in light of European law and Belgium law provisions.

3.1 EU law

RAN sharing is permitted under EU law but limited due to application of competition law principles.

3.1.1 Infrastructure sharing is encouraged under the EU regulatory framework

Infrastructure sharing is permitted and even encouraged under the EU electronic communications regulatory framework. The new article 8.5 (d)¹ of the Framework Directive provides that national regulatory authorities (NRAs) shall promote *“efficient investment and innovation in new and enhanced infrastructures, including by ensuring that any access obligation takes appropriate account of the risk-incurred by the investing undertakings and by permitting various cooperative arrangements between investors and parties seeking access to diversify the risk of investment, whilst ensuring that competition in the market and the principle of non-discrimination are preserved”*.

The new Directive 2009/140/EC highlights in particular that *“improving facility sharing can significantly improve competition and lower the overall financial and environmental cost of deploying electronic communications infrastructure for undertakings, particularly of new access networks”*.²

Obligations to share network elements and associated facilities may also be imposed under symmetric or asymmetric ex ante regulation.

Amended Article 12 of the Framework Directive empowers NRAs, “taking full account of the principle of proportionality,” to require networks to share network elements and associated facilities *“including buildings, entries to buildings, building wiring, masts, antennae, towers and other supporting constructions, ducts conduits, manholes [and] cabinets”*. Member States must hold public consultations before imposing such requirements, and must justify them *“in order to protect the environment, public health, public security or to meet town and country planning objectives”*.

Amended Article 12 of the Access Directive provides that an NRA may impose obligations on operators that hold significant market power (SMP) to meet reasonable demands for access and, use of, specific network elements and associated facilities, including access to network

¹ This article was introduced by Directive 2009/140/EC.

² Recital (43) of Directive 2009/140/EC

elements which are not active. SMP operators may, under this article sub-section (1)(f), be required “to provide co-location or other forms of associated facilities sharing”.

3.1.2 RAN sharing agreements must comply with infrastructure based-competition and frequency regulation

Voluntary network elements sharing agreements are permitted under EU law provided that such agreements do not include sharing of frequencies or core elements of the network which would deprive network operators of their competitive autonomy.

Network elements sharing agreements must comply with the main principles of the existing EU electronic communications framework and in particular with the principle of promoting infrastructure based-competition set forth in Article 8.5 (c) of the Framework Directive. The depth of co-operation between the parties to the sharing agreement thus normally must maintain a minimum degree of independence required to allow independent control of networks and services by the respective parties. Therefore, sharing agreements should not include core elements of the network which would prevent network operators from exercising a minimum degree of control over the exploitation of their network, in a way that would distort competition.

Any such sharing arrangements also must respect provisions of the EU framework that prevent spectrum hoarding (Framework Directive Article 9.7) and ensure that transfers or leases of spectrum do not distort competition (Authorisation Directive Article 5.6).

3.1.3 RAN sharing effects on competition must be assessed on a case by case basis

Agreements which restrict competition are prohibited by European competition law and under Article 101 of the Treaty on the Functioning of the European Union (ex article 81 TEC) in particular, subject to some limited exceptions. This provision covers a wide variety of behaviors which could include network sharing agreements if undertaken in an anti-competitive manner:

Article 101

"1. The following shall be prohibited as incompatible with the internal market: all agreements between undertakings, decisions by associations of undertakings and concerted practices which may affect trade between Member States and which have as their object or effect the prevention, restriction or distortion of competition within the internal market, and in particular those which: [...] (b) limit or control production, markets, technical development, or investment;"

The application of this rule has been considered in detail in decisions concerning infrastructure sharing and national roaming agreements for the 3G networks on the UK and German markets.

In its decision of 30 April 2003 in the case O2 UK Limited/T-Mobile UK³, the Commission held that the site sharing arrangements provided in the agreement between O2 UK and T-Mobile UK did not restrict competition. The Commission considered that the co-operation would extend only to basic network elements and that T-Mobile and O2 would each “*retain independent control of the key components of their access networks as well as their core networks, including all intelligent parts of the network and the service platforms that determine the nature and range of service provided*”.⁴

The Commission warned that RAN sharing could restrict competition since “*the Parties would have a significant level of costs in common which could facilitate the coordination of market prices and output*”.⁵ However, the UK agreement did not provide for extensive RAN sharing and therefore the level of common costs arising from sharing network components was likely to be low. Consequently, the risk for the UK agreement to restrict competition was correspondingly low.⁶

The Commission expressed some concern over provisions of the agreement relating to sharing sites, mainly relating to exclusivity arrangements and rights of first refusal. It noted, nevertheless, that there did not appear to be a shortage of sites available. Moreover, it noted that “[s]ite sharing is increasingly prominent amongst mobile operators and around 26 % of all external sites are shared sites.”⁷ It thus found that these provisions did not harm competition, after the Parties slightly amended their provisions on license fees for third party leasing of sites.⁸

Another aspect of the case involved reciprocal roaming arrangements. The Commission was concerned that these arrangements restricted competition at the wholesale level with potential harmful effects in downstream retail markets. The Commission stated:

National roaming between network operators who are licensed to roll out and operate their own competing mobile networks by definition restricts competition between those operators in all related network markets on key parameters such as coverage, quality and transmission rates. It restricts competition on coverage because instead of rolling out its own network to obtain the maximum degree of coverage of territory and population, a roaming operator will rely on the degree of coverage achieved by the network of the visited operator. National roaming also restricts competition on network quality and on transmission rates, because the roaming operator will be restricted by the network quality and the transmission rates available to it on the

³ European Commission, Decision of 30 April 2003 relating to a proceeding under Article 81 of the EC Treaty and Article 53 of the EEA Agreement (Case COMP/38.370: O2 UK Limited/T-Mobile UK Limited) (2003/507/CE), OJ L200, 7 August 2003, page 59

⁴ Id., paragraph 87

⁵ Id., paragraph 88.

⁶ Id.

⁷ Id., paragraph 98.

⁸ Id., paragraph 106.

*visited network, which are a function of the technical and commercial choices made by the operator of the visited network.*⁹

This analysis could apply to other forms of infrastructure. After an extended assessment of the conditions of the sharing and its market impact, the Commission held that it could be permitted for a set period of time in order to provide better coverage, quality and transmission rates for 3G wholesale and retail services more quickly.¹⁰

This decision should be read in conjunction with the Commission's 16 July 2003 decision as regards the agreement between O2 Germany and T-Mobile concerning site sharing and national roaming in Germany.¹¹ This decision is consistent with the decision concerning the UK agreement, in that the Commission held that the site sharing arrangements did not unduly restrict competition. Again, it considered that the co-operation would extend only to basic network elements and would maintain the *"minimum degree of independence required to allow independent control of networks and services by the respective Parties"*.¹² The key finding seemed to be that T-Mobile and O2 would each:

"retain independent control of their core networks including all intelligent parts of the network and the service platforms that determine the nature and range of service provided. The Parties also retain independent control over their radio planning and the freedom to add sites, including non-shared sites, in order to increase their network coverage and capacity, which appear to be the main competitive parameters at network level, and which are likely to have an important impact on the level of services competition".¹³

The agreement included the possibility of RAN sharing arrangements, but such sharing was not presently foreseen, according to the Commission. Moreover, this possibility was not covered in sufficient detail by the Parties in the notification. Thus, the Commission did not analyse or cover this possibility in its decision.¹⁴ Just as in the previous UK decision, the Commission found that the national roaming arrangements could restrict competition. However, the Commission granted a provisional exemption in order to facilitate rapid roll-out of 3G networks and to make 3G services more widely available.¹⁵

O2 Germany appealed the Commission's decision concerning the German national roaming arrangements to the European Court of First Instance (CFI). O2 Germany argued that the

⁹ Id., paragraph 116.

¹⁰ See Conclusion, id., paragraph 149. The Commission held that the agreement "leaves scope for effective competition between the Parties." Id., paragraph 145.

¹¹ European Commission, Decision of 16 July 2003 relating to a proceeding under Article 81 of the EC Treaty and Article 53 of the EEA Agreement (Case COMP/38.369: T-Mobile Deutschland/o2 Germany: Network sharing) (2004/207/CE) Case COMP/38.369, OJ L75, 12 March 2004, page 32.

¹² Id., paragraph 102.

¹³ Id.

¹⁴ Id., paragraph 104.

¹⁵ Id., paragraph 133. The Commission considered this national roaming to be indispensable to the benefits of the overall agreement.

Commission concluded that the national roaming arrangements were inherently restrictive of competition without engaging in the economic analysis required by the ex article 81 and by in particular failing to consider what the conditions of competition would be in the absence of an agreement.

In its 2 May 2006 decision, the CFI agreed with O2 Germany and concluded that the Commission's decision

*“suffers from insufficient analysis, first in that it contains no objective discussion of what the competition situation would have been in the absence of the agreement, which distorts the assessment of the actual and potential effects of the agreement on competition and, second, in that it does not demonstrate, in concrete terms, in the context of the relevant emerging market, that the provision of the agreement on roaming have restrictive effects on competition, but is confined, in this respect, to a petitio principii and to broad and general statements”.*¹⁶

To conclude, a competitive assessment of mobile infrastructure sharing agreements must be performed *in concreto* and on a case by case basis. In addition, as highlighted by the Commission, network elements sharing agreements must maintain a “*minimum degree of independence required to allow independent control of networks and services by the respective parties*”. Network operators must “*retain independent control of their core networks including all intelligent parts of the network and the service platforms that determine the nature and range of service provided*”.

3.2 Belgian law

At the Belgian level, the provisions of the EU directive concerning the sharing of antenna sites have been transposed in section III of the Act of 13 June 2005 on electronic communications (Articles 25 to 27). Through these articles, the Belgian legislator strongly encourages operators to share their antenna sites (mast, pylon, etc.) and even imposes on them the requirement to inform their competitors during each installation of a new aerial in order to allow them to consider sharing the facility.

However, this obligation only concerns the sharing of antenna sites (i.e. masts, pylons and other buildings used to this end). There is no specific legislation dealing with the question of more intensive infrastructure sharing, on the level of the antenna (RAN-sharing, etc.) or more central elements of the mobile operators’ networks.

¹⁶ Paragraph (116), Judgement of the Court of First Instance (Fourth Chamber), 2 May 2006, in case T-328-03, O2 (Germany) GmbH & Co.OHG v Commission of the European Communities

The 2G Royal Decrees¹⁷ provide, at article 2§1 respectively, that *“The authorization covers the implementation and the exploitation in Belgium of a mobile network and service using the GSM standard in the 900 MHz band”* [or] *“the DCS-1800 standard in the 1800 MHz band”*.

The 3G Royal Decree¹⁸ lays down, in its article 2, §1er that *“The authorization covers the implementation of a land mobile telecommunications network of the third generation and the exploitation of the offered corresponding services, by the 3G operator, to the public through the intermediary of the network”*. In the same Royal Decree (art. 1,7°) a network is defined as the *“whole of selector switches, controllers and base stations necessary to offer a mobile telecommunication service”*.

The 4G Royal Decree¹⁹ sets forth that *“Usage rights cover the implementation of radioelectric access systems over the entire national territory”*.

Nothing in these provisions requires the holder of the authorization to be the exclusive owner of the network used to exploit the services or seems to prevent an operator to agree with another on the buy-back/rent/any other formula contemplating the shared use of antennas or other infrastructure elements.

To conclude, infrastructure sharing, including RAN sharing, is permitted under Belgian law.

3.3 Spectrum Pooling

Spectrum pooling, as can be envisaged in a GWCN configuration and whereby operators are making a joint usage of one spectrum block, is problematic under Belgian law²⁰. This can be derived from the fact that the licence is a personal licence²¹; usage rights cannot be transmitted to another party, except in the case of spectrum trading. Upon such trading, the relevant usage rights are transferred to the new owner, who becomes responsible for all regulatory obligations attached to such usage rights. Pooling would on the contrary imply that usage rights are owned jointly by two (or more) operators. This would create a number

¹⁷ Royal decree dated 7 March 1995 related to the implementation and exploitation of GSM networks; Royal decree dated 27 October 1997 related to the implementation and exploitation of DCS-1800 networks

¹⁸ Royal decree dated 18 January 2001 setting forth the conditions and procedure for the grant of 3G mobile telecommunications authorisations

¹⁹ Royal decree dated 22 December 2010 related to the radioelectric access in the 2500-2690 MHz band

²⁰ This situation is also present in a number of European countries as mentioned in the recent BEREC/RSPG Report on infrastructure and spectrum sharing: *“Generally, in EU countries, every MNO must use its own frequencies to deploy the radio access network, and in this sense frequency sharing is not allowed (eg. ES), or subject to limitations.”* (Joint BEREC/RSPG Report on Infrastructure and spectrum sharing in mobile/wireless networks, 16 June 2011, RSPG11-374 final)

²¹ See Articles 3§1 of the 2G Royal Decrees; Art. 18 §1 of the 3G Royal Decree; Article 35§1 of the 4G Royal Decree

of practical problems and consequences that are incompatible with other provisions of Belgium rules on spectrum licenses (e.g., who would pay the fees, who is responsible²² in case of interference or radiation caps, etc.).

It can nevertheless be argued that, even in the case of pooling, there may be still sufficient alternative ways for differentiation and that pooling is, as such, not anti-competitive. Evolving technology could also allow additional independency.

The BIPT does however recognize that pooling of frequencies may offer particular advantages, e.g.:

- In order to benefit from the full advantages of LTE , it is necessary to have a continuous block of 20 MHz.
- In the case of the 800 MHz band, the total available bandwidth is only 2 times 30 MHz. Division into small blocks which cannot be pooled will limit the efficient use of this highly valuable spectrum.

The legality of joint ownership (pooling) seems uncertain given the current Belgian regulation on spectrum trading. However, this question becomes academic if the proposed "poolers" create a new entity. In that case, the spectrum trading regime would apply, with BIPT evaluating the proposal on a case by case basis, evaluating among other things the effect on competition.

It is clear that any trading of spectrum can only be carried out within the limits of the applicable spectrum caps and with full respect of other legal and regulatory conditions. To conclude, infrastructure sharing, including RAN sharing, is permitted under Belgian law provided that each operator remains the sole user of the frequencies allocated or transferred to it.

²² See in particular Article 9 of the GSM Royal Decree and article 10 of the DCS-1800 Royal Decree which provide that each operator is responsible for the usage of its network.

4 Main operational impact and pros and cons of mobile infrastructure sharing

In this section we summarise the impact of the use of different sharing configurations on operators, as well as the pros and cons of mobile infrastructure sharing.

4.1 Main operational impacts

4.1.1 Geographical limitations

Mobile infrastructure sharing could technically be implemented on a national level. However, in practice, operators have adopted RAN sharing in specific regions (where there is a clear economic benefit). In addition, regulators may adopt specific conditions related to the geographical extent of mobile infrastructure sharing such as:

- encouraging mobile infrastructure sharing in specific areas of the country, such as areas where there is no mobile coverage or where only one mobile operator covers this area, to boost service availability and to increase competition
- not allowing RAN sharing in specific areas, such as major cities, to avoid potential competition distortion in densely populated areas.

In this context, some regulators in Europe have imposed certain restrictions on mobile infrastructure sharing and national roaming related to geographical limitations. For example, in Sweden, Hi3G Access and Telenor had in their licence conditions to achieve at least 30% of population coverage with their own infrastructure before using other operator network to extend their coverage.

In France, ARCEP has set guidelines in 2009 to identify areas where 3G RAN sharing should be implemented. The main parameters that should be taken into account to identify these areas are:

- the current coverage and deployment of 3G networks for the different operators and the roll-outs planned in the different areas
- the current situation of the 2G network deployment in the different areas
- the geographical extent and territorial coherence of the areas considered
- the impact on the environment.

ARCEP considered that it is not necessary to impose an obligation of 3G RAN sharing for the first 95% of the population, because 97% of the population is already covered by all French operators with 2G technology.

However, ARCEP would welcome favourably any RAN sharing initiative within geographical areas for the first 95% of the population if this initiative were not to interfere with market competitiveness.

4.1.2 Operational constraints

There are several technical and operational constraints that must be taken into account when implementing sharing agreements. These constraints are summarised below.

- Network governance is a key element in the success of mobile infrastructure sharing and should be clearly defined in order not to generate operational difficulties during the deployment and operation of the network .
- Passive sharing requires the consideration of many technical and operational factors such as load bearing capacity of towers, azimuth angle of different operators, tilt of the antenna, height of the antenna, load bearing capacity of rooftop sites, the amount of space to house additional equipment, and the number of antennas that can be placed in urban sites.
- RAN sharing may have a negative impact on quality of service due to the reduction of signal strength when antennas are combined (although this does not apply to leading 3G RAN sharing techniques).
- MOCN and GWCN sharing configurations affect the independence of operators and licence holders as they are sharing usage rights (i.e. spectrum) and have a common core network, in the case of GWCN, which would not allow the operators to differentiate services in terms of availability and network quality.

4.2 Pros and cons of RAN sharing

4.2.1 Pros of RAN sharing

The main pros of RAN sharing, summarised below, are:

- cost savings
- acting as a viable alternative to mergers and acquisition (M&A) activity
- rapid deployment and coverage, and service availability
- Impact on competition
- consumer benefits
- environmental benefits
- spectral-efficiency benefits
- better quality of service.

Cost savings Mobile infrastructure sharing provides both opex and capex reductions for mobile operators. These benefits can differ depending on the

context :

- joint venture new build – for example, two operators jointly rolling out an LTE network, or
- consolidation of two established networks – operators agree to share a fraction of two existing networks.

Savings are more important in the case of a new build than for a sharing/consolidation initiative, as operators expect to incur significant capex on a new build.

The degree of savings depends on the depth of the sharing agreement (see below).

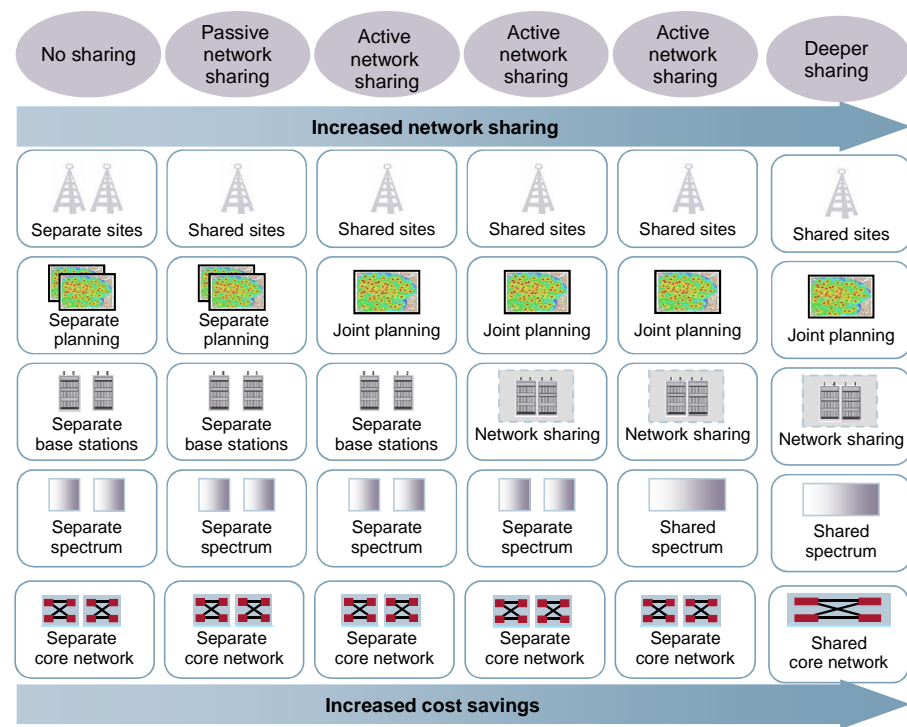

Figure 4.1: Levels of network sharing [Source: Analysys Mason]

RAN sharing will also enable partners to consolidate their choice of future network equipment design and possibly increase their negotiating strength with vendors.

Viable alternative to M&A activity

The cost of maintaining data networks may begin to erode operators' profit margins and will eventually outstrip revenue. Operators will increasingly rely on LTE technology, which is optimised to carry data at a greatly reduced cost in comparison with legacy networks. LTE has the benefit of improved spectral efficiency and a flat RAN architecture, which reduces network carriage costs. However, building an LTE network is a major investment, and some operators will only be able to

afford it if they do not share the cost. In this case, LTE network sharing may be a viable alternative to M&A activity or new build out. Deploying a new LTE network offers operators the chance to plan a shared network without falling into disputes over the value of existing assets, which has happened with many non-greenfield network-sharing agreements.

<i>Rapid deployment and coverage, and service availability</i>	<p>RAN sharing may accelerate the roll-out of new mobile networks, providing coverage to rural areas in a shorter time than would be expected were a single operator to roll out a network without a sharing agreement. This approach will also accelerate the migration of users, for example, from 2G to 3G, and so enable the early closure of 2G networks.</p>
<i>Impact on competition</i>	<p>Both passive and active sharing may benefit competition by offering mobile services in areas where a service would otherwise not be available. The European Commission referred in its decision COMP/M.6550 (T-Mobile/Orange) par. 130 to the possibility of other operators pooling spectrum at 1800MHz in order to create another competitive LTE operator. Therefore it is correct to say that spectrum pooling can in some cases have pro-competitive effects.</p>
<i>Consumer benefits</i>	<p>Both passive and active sharing may benefit consumers by increasing consumer choice and reducing the cost of services. Infrastructure sharing may be a useful tool for stimulating mobile broadband provision in areas that may otherwise be uneconomical to serve.</p>
<i>Environmental benefits</i>	<p>Environmental concerns have become more prevalent in the past ten years. Infrastructure sharing can contribute towards broader environmental goals and mitigate citizen concerns over base station radiation. Passive and active sharing can mitigate the visual impact of mobile networks on the landscape by reducing the total number of masts and towers. Sharing power supplies reduces energy consumption, which helps support government and corporate policies on reducing carbon emissions.</p>
<i>Spectral-efficiency benefits</i>	<p>Spectrum pooling for MOCN and GWCN configurations or sharing of backhaul microwave frequencies encourages the optimal use of spectral resources, however spectrum pooling could seriously limit operators' independence and would be contrary to the exclusive and personal character of the licences.</p>
<i>Better quality of service</i>	<p>Through combining their spectrum, partners are able to offer higher LTE peak rates to consumers.</p>

4.2.2 Cons of RAN sharing

The main cons of RAN sharing, summarised below, are:

- risks and costs associated to RAN sharing
- reduction of investments
- impact on competition
- impact on electromagnetic field emission limits.

Risks and costs associated to RAN sharing All sharing agreements require an extensive period of planning. If the agreement is related to the consolidation of an existing network, then there is an expenditure of capital associated with this. The cost depends on the degree of consolidation, which could entail significant removal costs:

- removal and storage of ground-based equipment from a site, and termination and removal of electrical equipment
- removal of antennas and feeders
- removal of the tower and fencing, and tidying up the compound and base area (for example, sites with associated parking or storage) in order to fully reinstate the site.

As part of the consolidation process, the partners will re-plan the network. They will inevitably need new sites, which will also entail capex, and maintaining them will require opex.

Reduction of investments RAN sharing agreements should eventually lead to cost savings, thereby reducing investment in networks. This could affect the level of activity perceived by main suppliers and equipment vendors.

Impact on competition Very deep mobile infrastructure sharing configurations such as GWCN and MOCN configurations, where spectrum pooling is allowed, could decrease the level of competition as partners may not be able to distinguish their services adequately because of similarities in their network coverage and quality of service. This has been a major consideration in the two Commission decisions on network infrastructure referred previously in Section 3.

In its July 2003 decision in the case of T-Mobile/O2 Germany, the Commission considered that since the co-operation would extend only to basic network elements and permit the operators to maintain the “*minimum degree of independence required to allow independent control of networks and services by the respective parties*”, the site sharing arrangements did not unduly restrict competition. T-Mobile and O2 would each “*retain independent control of their core networks including*

all intelligent parts of the network and the service platforms that determine the nature and range of service provided The Parties also retain independent control over their radio planning and the freedom to add sites, including non-shared sites, in order to increase their network coverage and capacity, which appear to be the main competitive parameters at network level, and which are likely to have an important impact on the level of services competition”.

This particular competition analysis is based on the situation in UK en Germany at that time under given circumstances and cannot be extrapolated to all other cases.

*Impact on
electromagnetic
field emission
limits*

Active and passive sharing could increase the electromagnetic field emissions. This would create issues if official electromagnetic field emissions limits would be exceeded (as operators would in this case not be able to share networks unless the regulation is subject to a revision).

5 Conclusions/Guidelines

In this section, we provide general guidelines on the different issues raised in this document. The guidelines suggested by BIPT take into account the following objectives :

- promoting the competitiveness of the market between the different actors, taking account of the fact that the benefits of sharing can outweigh the disadvantages of reduced coverage and capacity differentiation.
- promoting the market development to the benefit of the end user
- allowing actors to optimise their costs as long as competition is not biased and operators are still technically and commercially independent
- ensuring the respect of licence conditions (mainly regarding spectrum usage and coverage obligations).

Overall, BIPT would like to emphasise that mobile infrastructure sharing in Belgium is allowed and needs no further authorisation, as long as operators are still commercially and technically independent, since a lack of independence could typically bias competition to the detriment of end users.

BIPT's views regarding the different forms of mobile infrastructure sharing are provided below. However, it should be noted that these views can evolve over time with technological evolution.

<i>Passive network sharing</i>	BIPT recognises that the shared use of wireless infrastructure can contribute significantly to lowering roll-out and/or operating costs. In particular, this would also drive and encourage a rapid and extensive network build and earlier provision of wireless access in rural areas. Therefore, in line with EU law principles, BIPT encourages passive network sharing between operators as this sharing benefit to market development and will not affect the independence of operators. The current legal framework should be examined with a view to possibly improve the current arrangements.
<i>Basic RAN sharing</i>	For similar reasons to those mentioned above, BIPT encourages basic RAN sharing between operators.
<i>MORAN</i>	BIPT does not have any objection to the MORAN sharing configuration, as long as operators follow the general recommendations, regarding the full independence of operators
<i>MOCN</i>	BIPT does not support the use of the MOCN sharing configuration, as operators share both the RNC and Node B and pool their spectrum, which would typically limit the scope for service differentiation and competition

in the market.

GWCN

BIPT does not support the use of the GWCN sharing configuration, as operators share parts of the core network in addition to the RAN. In addition, operators either pool spectrum, or use the spectrum of one of the sharing parties. This prevents physical or logical separation of the sharing operators' networks and, therefore, little differentiation is possible in terms of coverage and network quality, which limits competition in the market.

Additional guidelines on the geographical and operational aspects of infrastructure sharing are provided below.

Geographical limitations

As long as BIPT's main objectives and operators' independence are ensured, BIPT is not in favour of imposing geographical limitations for RAN sharing. First, BIPT sees no concrete rationale to prevent sharing in some specific geographical parts of Belgium (if operators' independence is ensured and therefore level of competition not impacted by such sharing). Second, defining criteria below which RAN sharing would be prevented (and above which RAN sharing would be allowed) appears extremely difficult and debatable. BIPT would rather to leave it to the market and to market players to decide if and where it is economically justified for them to share networks.

Operational guidelines

BIPT suggests that the following aspects should be taken into account in mobile infrastructure sharing agreements:

- operators should independently control cell-level parameters in order to minimise the effect of sharing on service, quality of service and coverage differentiation
- operators should ensure that they control the operation of Node Bs and RNCs, so they can access them independently of the sharing partner to undertake key actions (e.g. independent start up or shut down, changes in power parameters, transmission power settings)
- operators should use only the frequencies assigned to them
- operators should manage radio resources independently (e.g. changes in data rates to implement various services for each operator)
- operators should not exchange competition-related data beyond the technical information required for operation (e.g. customer data, service parameters, traffic volumes)

- operators should be able to operate different software versions in the RNCs, and each operator should be able to update its software independently of the sharing partner
- operators should have a separate network operations centre (NOC) in order to ensure that access to information from the other party is strictly limited to information required for operations. In the case of outsourcing of the NOC to an independent third party, this third party may operate a common NOC for both operators but will have to ensure (and demonstrate) that confidential information is not shared between operators.
- operators should have the ability to operate additional base stations independently of the sharing arrangements (i.e. planning autonomy guaranteed)
- operators should not divide coverage areas in such a way that one party in the agreement cannot also provide coverage in the sharing area.

*Framework
agreement*

Prior to implementing a mobile infrastructure agreement, operators should develop a framework agreement to be shared with BIPT. This framework agreement should include at least:

- the areas identified for RAN sharing (if the agreement does not cover the whole Belgian territory)
- the technical solutions that will be implemented
- the governance mode that specifies the responsibilities of each operator and the decision-making process
- the type of information that will be shared between operators, which should be limited to the minimum information needed for sharing arrangements
- the financial conditions related to sharing, which should be fair for all operators.

This approach will permit BIPT to carry out a preliminary assessment of the effects of the agreement on the market and to verify that planned arrangements do not deprive operators of competitive autonomy.

It should be noted that any interconnection agreement, or any agreement related to access should be communicated to BIPT in its integrity.

