

Report for BIPT

Consultation document for the draft NGN/NGA models

23 December 2011

Ref: 17915-516e



Contents

1	Introduction	1
2	Model principles	3
2.1	Choice of operator in the cost calculation	3
2.2	Implementation of the model	6
3	Calculation modules	17
3.1	Module 0: Market	17
3.2	Modules 1 + 2 + 3 + 4 + 6: Core	18
3.3	Modules 5 + 7: Access	22
3.4	Module 8: Various colocation calculations	24
3.5	Module 9: SNA	25
3.6	Module 9: Updated one-time fees	25
3.7	Module 14: Improved service level agreements (ISLA)	27
3.8	Module 15 + 16 + 17: HMC, IT and OH	29
3.9	Module 20 + 21 + 22 + 23: Service costing	31
3.10	Module 13: CPE	31
4	Responding to this consultation	33
Annex A	Draft numerical results	
Annex B	Glossary of terms	

Copyright © 2011. Analysys Mason Limited has produced the information contained herein for BIPT. The ownership, use and disclosure of this information are subject to the Commercial Terms contained in the contract between Analysys Mason Limited and BIPT.

Analysys Mason Limited
St Giles Court
24 Castle Street
Cambridge CB3 0AJ
UK
Tel: +44 (0)845 600 5244
Fax: +44 (0)1223 460866
cambridge@analysysmason.com
www.analysysmason.com
Registered in England No. 5177472

1 Introduction

Analysys Mason Limited (‘Analysys Mason’) has been commissioned by the Belgium Institute for Postal Services and Telecommunications (‘BIPT’) to develop a bottom-up cost model of a fixed next-generation core and access network to calculate the unit costs of the services provided on the network.

This report is the consultation document on the draft version of the bottom-up cost model developed for BIPT.

Background

The draft model, comprising a number of modules, has been made available to industry parties for consultation. The draft model exists in three versions:

- the first version of the draft model is accessible only to BIPT because it contains confidential information, including market-demand information which is not publicly available to the industry
- the second version of the draft model is provided to Belgacom only because it contains confidential information from Belgacom, but not confidential market-demand information
- the third version of the draft model is provided to the industry parties with the confidential information from Belgacom redacted and/or replaced with coarse order-of-magnitude inputs.

The draft bottom-up cost model comprises a number of separate calculation modules, as shown below in Figure 1.1. Some of these modules are prepared in different forms for the three versions of the draft model issued for consultation:

<i>Module number</i>	<i>Version provided to BIPT</i>	<i>Version provided to Belgacom</i>	<i>Version provided to industry</i>
Module 0: Market	Complete	Only operator demand total	Only operator demand total, partially rounded
Modules 1 + 2 + 3 + 4 + 6: Core	Complete, including off-line geo-analysis file	Complete, including offline geo-analysis file	Partially rounded, excluding geo-analysis file
Modules 5 + 7: Access	Complete	Complete	Partially rounded
Module 8: Quotation fee	Complete	Complete	Confidential to Belgacom. Not provided.
Module 8: Admin Fee	Complete	Complete	
Module 8: Colo_POW_AlimentationUpgrade	Complete	Complete	
Module 8: Floor space cost	Complete	Complete	
Module 8: Power HVAC Gladiator Cost	Complete	Complete	
Module 8: Colocation summary	Complete	Complete	Table of results is presented in an annex to this document

<i>Module number</i>	<i>Version provided to BIPT</i>	<i>Version provided to Belgacom</i>	<i>Version provided to industry</i>
Module 9: SNA	Complete	Complete	Confidential to Belgacom. Only results and key inputs are provided. Table of relevant results is presented in an annex to this document
Module 9: Updated one-time fees	Complete	Complete	
Module 14: ISLA	Complete	Complete	
Module 15 + 16 + 17: HMC, IT and OH	Complete	Complete	
Module 20 + 21 + 22 + 23: Service costing	Complete	Complete	Partially rounded
Module 13: CPE – in <i>PowerPoint</i> not <i>Excel</i>	Complete	Complete	Complete

Figure 1.1: Draft model versions issued for consultation [Source: Analysys Mason]

Structure of this document

The remainder of this consultation document is laid out as follows:

- **Section 2** outlines the principles which have been applied in the development of the model
- **Section 3** presents the scope, key issues and consultation questions associated with each calculation module
- **Section 4** explains how to respond to this consultation paper.

The report includes a number of annexes containing supplementary material:

- **Annex A** includes a table of relevant model results.
- **Annex B** includes a glossary of terms used throughout this consultation document.

2 Model principles

This section explains the principles that are applied in the cost calculations within the bottom-up model, arranged according to guiding principles applying universally to the whole model, and methodological principles applying to each module of the calculation. This is illustrated below in Figure 2.1.

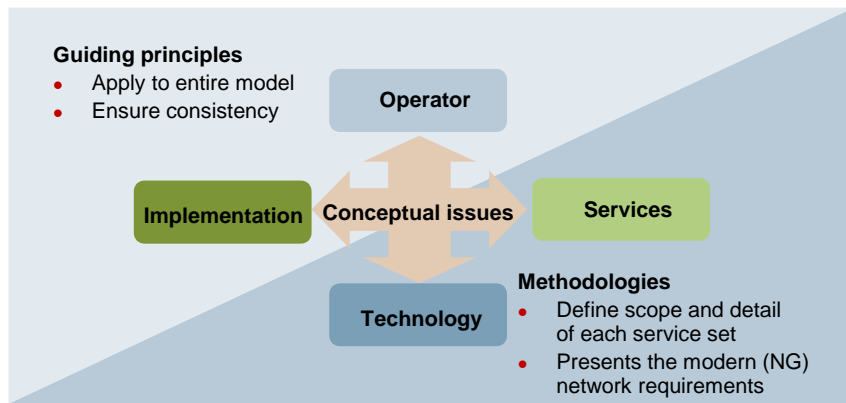

Figure 2.1: Model principles overview
[Source: Analysys Mason]

2.1 Choice of operator in the cost calculation

Regulated cost-based wholesale prices must be set on the basis of a cost calculation for an (efficient) operator offering the services. The services which are being considered in this project encompass the wide variety of fixed network services offered by Belgacom in the wholesale markets. These include:

- voice interconnection (SS7 interconnect and IP interconnect in the future)
- rental of unbundled copper local loops
- bitstream access for end-customer Ethernet data streams/wholesale broadband access
- Ethernet transport
- other services such as colocation, service migrations and ‘small network adaptations’ to the in-street copper distribution cables.

The choice of operator is governed by its type, footprint and scale.

The approach used in the bottom-up model consists of applying only one choice of operator to consistently calculate the cost of all the regulated services. We do not apply different operator definitions depending on the wholesale product being considered.

Question 1.	Do you agree with the consistent application of one operator definition to all the regulated wholesale services?
--------------------	--

2.1.1 Type of operator

The type of operator being modelled is the first principle that needs to be defined for the cost calculation. The draft cost model reflects an **existing efficient operator based on Belgacom**.

Existing The cost calculation assumes that the operator is already in existence, and does not need to enter or grow in the market like a new, or later, entrant. It has its full share of the market and a full existing passive copper access network.

Efficient Modern active electronics are deployed, with a level of efficiency in the roll-out timescales, utilisation and operational costs of voice and data assets which are *not less efficient* than Belgacom.

The modelled operator may be more efficient than Belgacom where the efficiency adjustments can be clearly motivated.

Based on Belgacom The existing operator is modelled over the same historical timescales as Belgacom (i.e. from the early years when Belgacom deployed its copper access network as a state-owned monopoly operator). The operator rolls out fibre to the cabinet (FTTC) and its next-generation network (NGN) IP-core in the same timescales as Belgacom, including the deployment approach for IP digital subscriber line access multiplexer (DSLAM) and voice access gateway (AGW) equipment. Consistent with BIPT's BRUO rental fee decision on 3 August 2010, the model considers an efficient operator deploying ducts in the feeder network from 1993 onwards, such that the costs of deploying *some* feeder fibre is reduced to just blowing fibre through these existing ducts.

The operator has a similar share of the market as Belgacom.

This approach ensures that the resulting costs of service are directly (efficiently) comparable to the services offered by Belgacom (the operator under regulatory consideration) particularly for services like unbundling where economies of scale are important. Reference points and input values can be obtained from Belgacom directly, without the need to transform comprehensive sets of inputs to a different operator situation (which would be the case for a new entrant model, for example). The existing operator approach allows the target core and access NGN to be outlined with reference to Belgacom's current plans, which will in most cases largely determine the availability of wholesale services on the Belgian market.

Whilst there are some drawbacks to using this approach – such as the requirement to disguise confidential information which is closely (or exactly) based on Belgacom's actual business information, and the requirement to specify 'efficient' roll-out profiles for NGN elements – these drawbacks are considered minor in comparison to the adoption of other operator types (such as a hypothetical new entrant model). This is because there are various other disadvantages of using other

operator types, for example not reflecting costs similar to Belgacom’s costs, requiring additional assumptions on network deployment, limited ability to compare the model with top-down data, etc.

Question 2.

Do you agree with the type of operator modelled?

2.1.2 Footprint of the modelled operator

The footprint of the modelled operator defines where its services are available.

The draft cost model assumes a **national network operator** with the same footprint as Belgacom’s copper pair access network, and a national core network. As a result, the modelled operator has the same number of active connected households as Belgacom.

The expansion of the modelled operator’s FTTC footprint is comparable with Belgacom’s historical roll-out of remote optical equipment, but then is assumed to continue to a full national FTTC roll-out in 2015.

It is assumed that the modelled operator’s core and access networks share the same trenches and ducts for two kilometres from the local exchange (or LEX), on each LEX-LEX route. This cost is shared 50:50 between the core and access network modules.

We also include sharing of the feeder FTTC footprint with fibre to the office (FTTO) services (including fibre to Belgacom’s mobile base stations). We assume that there are eventually two fibre cables in each feeder fibre route (duct) – one for FTTC and one for FTTO. The cost of feeder trench and duct is therefore shared 50:50 between these two service functions in the long term.

Question 3.

Do you agree with our choice of modelling an operator with the same national footprint as Belgacom’s copper pair access network?

Do you agree with the type and degree of footprint-sharing assumed?

2.1.3 Scale of the modelled operator

The scale of the modelled operator is defined as its market share of access connections and core network traffic.

The draft cost model applies a scale that is **based on Belgacom’s actual scale**.

For the purposes of public consultation, the amount of market information that can be shared with the industry is limited. BIPT does not disclose full market share information for Belgacom or other players in the market, and a number of underlying market parameters may be based on confidential information from Belgacom. As such, we do not present the precise market share percentages and parameters applied to the calculation of the demand that is supported by the modelled operator, and a number of other market-related parameters (such as average call duration) are rounded for public presentation.

The application of this chosen scale principle means that the calculated costs most closely reflect those of the incumbent operator – this is consistent with the intended application of the model primarily to Belgacom’s wholesale products.

Question 4.	Do you agree with the choice of Belgacom’s actual scale?
--------------------	--

2.2 Implementation of the model

Implementation issues govern the construction and cost calculations of the model. As such, they should be consistently applied across the whole calculation model. The two important implementation principles of *increments* and *depreciation* are covered below, along with a number of other universally applicable aspects.

2.2.1 Structure

A model structure may be top-down or bottom-up in approach.

We have developed a **bottom-up cost model** for BIPT. However, this bottom-up model is not developed in isolation. Instead, it has been **validated with top-down information** from Belgacom, as well as adopting a number of inputs that have been derived from Belgacom’s top-down information adjusted for efficiency in a number of particular areas.

A bottom-up cost model is necessary for transparency, objectivity and to facilitate industry consultation. The incorporation of top-down checks and validation improves the robustness of the model results, ensuring that (to the extent necessary) the model reflects real-life operational aspects.

Question 5.	Do you agree with the bottom-up approach?
	Do you have any comments regarding the use of top-down data from Belgacom to validate the model results?

2.2.2 Increments

Cost models may use ‘fully allocated’ or ‘incremental’ costing methods for the allocation of costs to services.

The draft cost model calculates a number of **incremental costs**. It does this in two cases:

Case 1: Pure incremental cost of wholesale voice termination

The draft cost model calculates the **pure incremental cost of wholesale voice termination** by calculating the costs that are avoided when the volume of traffic is removed from the network in the long run. This is illustrated below in Figure 2.2.

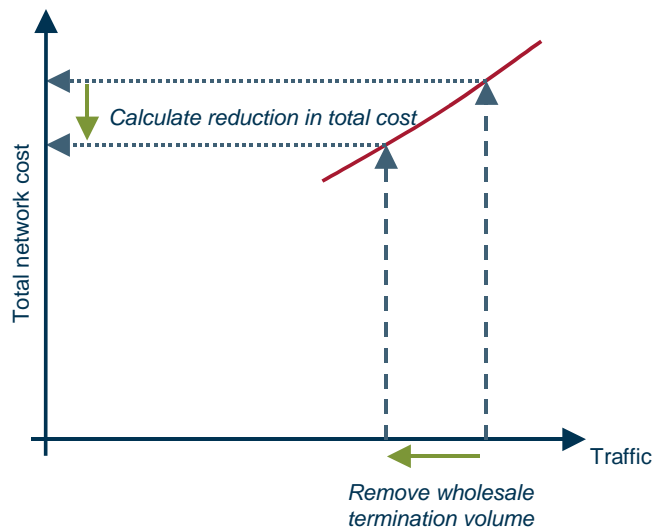

Figure 2.2:
Calculating the pure incremental cost of wholesale voice termination
[Source: Analysys Mason]

The model performs this calculation using a macro which runs the model twice and records the two sets of calculated capital and operating expenditure *with* and *without* wholesale termination. The difference in expenditure in each year is calculated, and then annualised over time using the economic depreciation algorithm and the weighted average cost of capital (WACC). By this method, the pure long-run incremental cost (LRIC) of wholesale voice termination reflects the underlying price trends applying to the equipment involved in satisfying the increment volumes, and reflects the total (avoided, incremental) volumes of termination traffic over the long run. The pure LRIC results also evolve consistently and comparatively with the voice LRAIC+ incremental costs in the other case.

This pure incremental cost calculation is consistent with the approach set out in the European Commission’s recommendation of 7 May 2009 on the regulatory treatment of fixed and mobile termination rates in the European Union (EU).¹ It is also consistent with the pure incremental cost method applied by BIPT in Market 7.

¹ Commission Recommendation of 7 May 2009 on the *Regulatory Treatment of Fixed and Mobile Termination Rates in the EU* (2009/396/EC). Available at <http://eur-lex.europa.eu/LexUriServ/LexUriServ.do?uri=OJ:L:2009:124:0067:0074:EN:PDF>.

Question 6. Do you have any comments on the pure LRIC calculation from the perspective of the bottom-up network design used to compute the cost components, or the per-minute annualised service costing (i.e. not related to pricing issues)?

Case 2: Long-run average incremental costs of large service groups

The cost model calculates the **marked-up long-run average incremental costs (LRAIC+)** of a number of large service groups (i.e. large increments):

- traffic in the core network
- subscriber and FTTO access lines
- various separate (wholesale) ancillary services.

Two sets of common costs are applied via a mark-up to give the LRAIC+ results:

- the relevant IT costs
- the ‘pure’ overheads costs.

This increment structure is illustrated below in Figure 2.3.

Average routing factors are used within each incremental cost to identify the relevant service costs, taking into account the constituent network element usage for each unit of service demand.

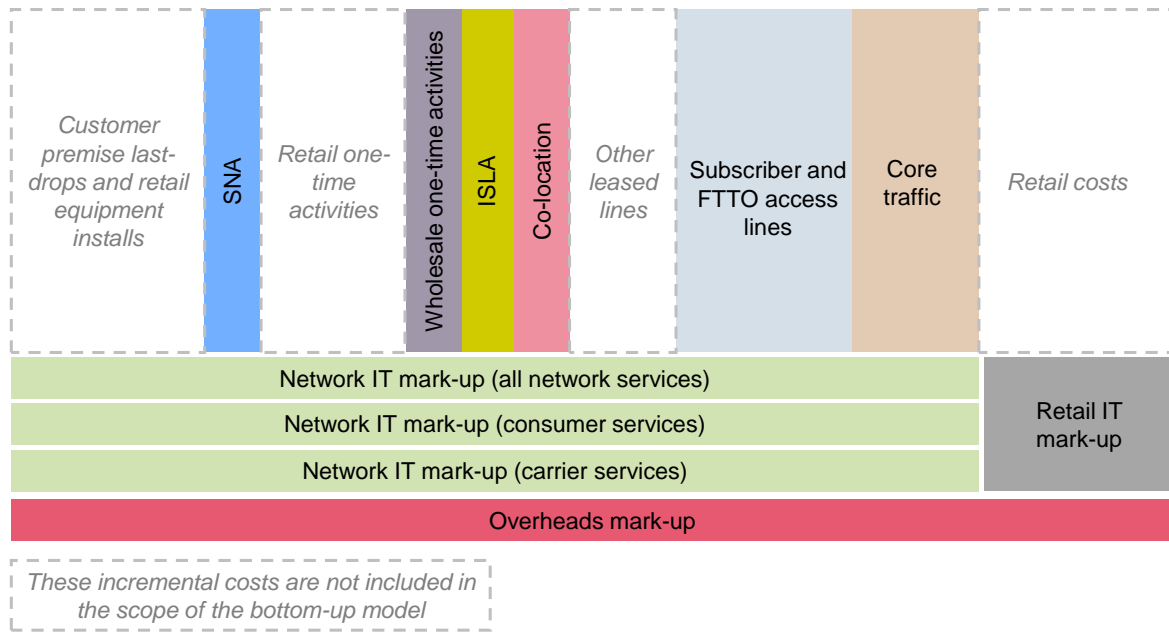

Figure 2.3: Large incremental costs [Source: Analysys Mason]

Question 7. Do you have any comments on the LRAIC and LRAIC+ calculations from the perspective of service costing (i.e. not related to pricing issues)?

2.2.3 Asset valuation and depreciation

A cost model will contain a schedule of network assets. At each or any point in time, the value of those network assets will be set out by the model. The value of assets at any point in time can be set on a historical or current cost basis, using a ‘regulatory asset value’, or based on some forward-looking economic or earning-power valuation. Some historical assets may be fully depreciated in accounting terms, and whether these are re-valued to a non-zero valuation at a particular point in time is also relevant.

The cost model will need to ‘depreciate’ or ‘annualise’ the selected asset value over time. In performing this calculation, a depreciation method might take into account a variety of factors:

- financial, economic or remaining asset lifetimes
- past and future input cost trends for the assets in question
- terminal values beyond the modelled period
- WACC for employed capital that is returned to the investors in later years.

The depreciation method may or may not also consider the profile of operating expenditure (opex) that the asset incurs over time.

The draft cost model applies a very specific form of asset valuation and depreciation, which has been carefully developed for the situation applying to Belgacom and the Belgian fixed network industry. This method has been set out according to the following two guiding principles, which should be applied to the entire cost model:

-
1. **Forward-looking cost recovery should be based on economic depreciation.**
 2. **Historical cost recovery applies before there are replicable assets deployed during competitive times.**
-

These principles, when applied to the modelled efficient existing operator based on Belgacom, mean that:

- All efficient assets modelled are accumulated over time on a historical valuation basis at the **(historical) and forecast asset prices paid**. There is **no revaluation** of assets at any particular point in time.
- Accumulated investments are depreciated **prior to 2001 on a straight-line historical cost accounting (HCA) basis**. Remaining unrecovered costs, plus new investment, plus ongoing opex are depreciated **from 2001 onwards on an economic depreciation (or ED) basis for the total remaining lifetime of the network element**. Within the remaining lifetime of the network element, there may be individual replacements of network elements; however, using economic depreciation, **opening values including all sequences of replacements are recovered over the full time period of the network element**.

- **No terminal value is included** beyond the long modelled period.
- The HCA and economic depreciation calculations **include a WACC** discounting/cost of capital employed.

This approach is illustrated in in Figure 2.4.

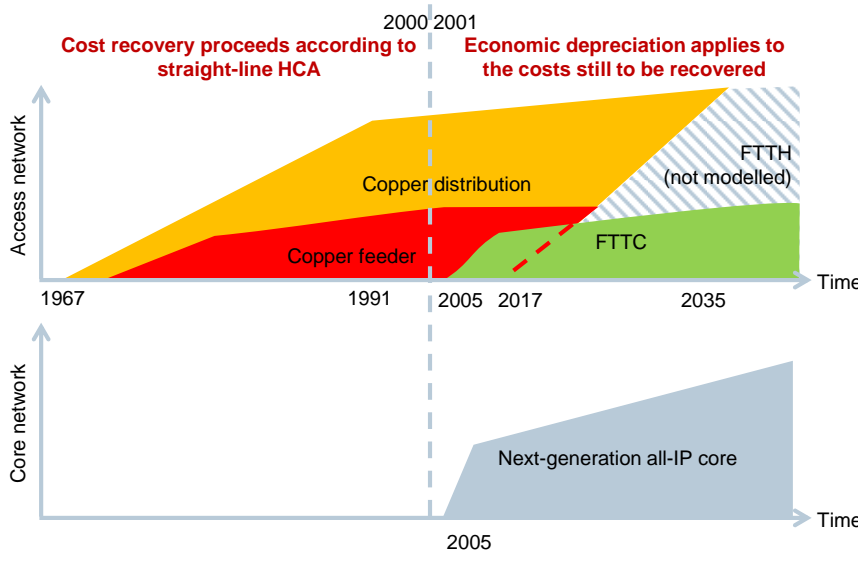

Figure 2.4: Illustration of full time series depreciation for the model [Source: Analysys Mason]

This valuation and depreciation approach is more complicated compared to single-year or single-method models which have been applied by regulators in the past. However, this method is reasonable for the situation in which BIPT proposes to set wholesale access prices for both the copper access and next-generation core networks of Belgacom. Below we outline the justification for each component of this guiding principle.

Forward-looking cost recovery based on economic depreciation

Standard economic theory supports this approach. It is also supported by the European Commission’s recommendation of 7 May 2009 on the regulatory treatment of fixed and mobile termination rates in the European Union (EU).²

Historical cost recovery applies before there are replicable assets deployed in competitive times

In this principle, it is important to set out the degree of replication and competition applying to the three main technical network components being modelled:

- **The next-generation core network of Belgacom**, deployed from around 2005 onwards. Core networks have already been replicated by a number of alternative network operators in Belgium.
- **The FTTC/FTTO feeder network** has been deployed recently (since

² Commission Recommendation of 7 May 2009 on the *Regulatory Treatment of Fixed and Mobile Termination Rates in the EU* (2009/396/EC). Available at <http://eur-lex.europa.eu/LexUriServ/LexUriServ.do?uri=OJ:L:2009:124:0067:0074:EN:PDF>.

around 2005) by Belgacom, when the market for subscriber access lines was open to competition (FTTC-VDSL specifically being deployed to compete with DOCSIS3 over hybrid fibre coaxial (HFC) networks). In many areas, the deep-fibre HFC cable networks will broadly match the feeder fibre footprint of Belgacom.

- **The copper access network of Belgacom** was largely deployed by the RTT (now Belgacom) which was a State-owned company that had a monopoly on the installation and supply of domestic telephony. Today, whilst the market for domestic telephony and subscriber access is liberalised – in some areas an alternative cable telephony service is available; in other areas wholesale access to copper is available – we do not consider that Belgacom’s copper access network is *replicable* or will ever be *replicated*. Even though there are no exogenous restrictions which would prevent an alternative network operator from deploying a parallel copper access network, this would not happen. Furthermore, no one expects Belgacom to replace its entire national copper access network with another national copper access network. Instead, Belgacom is likely to replace its copper access network with a fibre access network – i.e. fully decommissioning the copper access cables in each zone that has active FTTH, and not operating parallel copper and fibre access footprints in the long run. Consequently, the copper access network of Belgacom is considered entirely a legacy, **non-replicable** asset that was (largely) deployed (by a State-owned company) before competition for subscriber access and telephony. We note that cable operators could offer domestic telephony and Internet access a few years before 2001; however, it would have taken a few years for the digital footprint of the cable network to be expanded to a material level for competitive purposes.

Historical and forecast asset prices paid; no revaluation

By accumulating the actual prices paid in the model (over all time – from the historical to the future periods) we do not need to undertake any asset revaluation calculations.

Revaluing large parts of the copper access network according to today’s metallic copper price would also imply a windfall gain for Belgacom (as the value of copper has increased significantly since the majority of the network was deployed).

The approach proposed for the model ensures no over-compensation for the costs of the legacy copper access network owned by Belgacom.

HCA prior to 2001

Prior to 2001, we assume that the modelled operator was not under any significant competitive constraint in terms of offering fixed telephony access lines. Prior to 1997, the Belgian government fully owned Belgacom, and operated it for many years as the monopoly provider of fixed access lines.

For all these cases prior to 2001 we apply HCA for the annualisation of

expenditures. Either:

- the monopoly operator can fully recover its accounting costs in each year, or
- any under-recovery caused by a difference between revenues and accounting costs would have been absorbed by the Belgian government.

economic depreciation from 2001 onwards

As the market for subscriber access lines and domestic telephony becomes competitive, operators offering services will be increasingly required (through the action of the competitive and contestable market) to offer services on an economic cost basis, rather than to make accounting profits on all products. This means, for example, considering the projected cash flows from the services supported by investments in new network elements.

Applying economic depreciation from 2001 onwards ensures a consistent treatment of all assets during competitive times (i.e. after market opening).

We also ‘annualise’ opex over time. This is to ensure that the costs of installing and operating the assets (their economic costs) are spread uniformly over time (subject to forecast opex cost trends) and to ensure that increases in opex per line (e.g. as the number of active lines declines) are shared out to all active lines over time rather than ramping up the costs of a line in later (final) years of the copper access network.

Total remaining lifetime of the network element, with opening values and expenditures recovered using economic depreciation over the full time period

Identifying a single value for the lifetime of the remaining copper access network is particularly challenging. Some parts of the copper access network will be replaced with fibre in the short term (e.g. fibre to the building). Other parts of the copper access network will be in use for a considerable future period. Also, Belgacom has not announced any official FTTH plans. As a result, instead of modelling a single remaining copper access asset lifetime, we have modelled a phased replacement profile for the network.

This approach ensures that we consider the total forecast remaining lifetime of the network. All the costs which are still to be recovered (opening values from 2001) plus the remaining current and future expenditures are recovered over the total remaining life of the assets, reflecting the number of active lines in operation.

This approach most closely reflects what we believe the real replacement profile of the copper access network will look like.

The proposed approach also considers FTTH – except that the costs of the FTTH network which replaces the copper network are not modelled. Consequently, we do not set out any official principles on which the

annualised costs of an FTTH network might be calculated (though our principles here could be consistently applied by BIPT if required).

No terminal value The terminal situation for the network elements modelled falls into one of two categories:

- the explicit ending of the network element is modelled (e.g. shut-down of the copper access network)
- the network element is operated until the end of the modelled period, with ongoing periodic replacements up to that point.

In both of these cases we do not model a terminal value. By 2050, any remaining terminal value would be small in comparison to the modelled 40 to 45 years. Modelling no terminal value at the end of the modelled period is also consistent with BIPT’s approach in the costing of wholesale mobile termination.

Including a WACC The HCA and economic depreciation calculations incorporate a cost of capital employed for the recovery of expenditures over time. In the economic cost calculation, both capex and opex are ‘annualised’ over time with the incorporation of a WACC (in the discounting of expenditures and output over time).

The valuation and depreciation approach is an important principle that is applied consistently to all network elements in the cost model. It contains a variety of component principles as discussed above.

Question 8.	<p>Do you agree with the proposed valuation and depreciation principles, at an overall and a detailed level?</p> <p>If not, please supply supporting justification as to why the proposed approach is not suitable, providing detailed motivation for your alternative proposal(s), with market and/or regulatory evidence applicable to Belgium where possible.</p>
--------------------	--

2.2.4 WACC

The cost model must apply a discount rate to the series of expenditures and output of the network.

BIPT calculated Belgacom’s **weighted average cost of capital (WACC) at 9.61% in nominal pre-tax terms for the period 2010 to 2013**. We propose to apply this WACC in the model from 2010 onwards.

BIPT also assessed Belgacom’s WACC in previous years. We propose to apply BIPT’s historical series of WACC derivations from 2001 to 2009.

Prior to 2001, we use the straight-line HCA method in our cost calculations for the access network model. We consider there to be two distinct periods prior to 2001:

- Firstly, when Belgacom was a fully state-owned operator – for these early years we propose to apply a 3.5% WACC in the HCA depreciation (reflecting a government cost of capital for investing in the state-owned telecoms infrastructure).
- Secondly, when the Belgian government sold shares in Belgacom (in 1997) – in this case, the source of investment for the business will have become the capital markets as opposed to government funds. As such, we apply a commercial WACC (equal to the 2001 value calculated by BIPT) for the period 1997–2001.

Because of the historical nature of depreciation in these years, the results from 2001 onwards are not sensitive to the pre-2001 WACC.

Question 9.	<p>Do you agree with the application of a WACC based on: i) historical state-owned investments for the period prior to 1997; ii) BIPT’s derivations for the period between 2001 and 2009, with the 2001 value applied back to 1997; and iii) 9.61% for 2010 and onwards?</p> <p>Do you have any other comments on the WACC input figure?</p>
--------------------	--

2.2.5 Mark-up mechanism

A mark-up mechanism is needed for network common costs and other overhead costs that must be applied to the cost calculation.

The draft cost model assumes that:

- there are no common costs in the core network elements – all costs, including network management systems, are treated as long-run average incremental costs of core network traffic or subscriber connections (or pure incremental costs in the case of the wholesale termination calculation)

- there are no common costs in the access network elements – all costs, including network management systems, are treated as long-run average incremental costs of access network subscriber connections
- all staff hourly costs and all exchange building floor space-related costs are treated as variable costs in the long run
- a proportion of IT costs are treated as common to all network services
- a proportion of IT costs are treated as common to network ‘consumer’ services³
- a proportion of IT costs are treated as common to network ‘carrier’ services⁴

³ **Consumer services** are the services supported by the network which are ultimately sold to Belgacom's retail residential and business customers, including resale to other service providers

- On-net calls (retail)
- Outgoing calls to other fixed operators (retail)
- Outgoing calls to non-geographic al numbers (retail)
- Outgoing calls to international (retail)
- Outgoing calls to mobile (retail)
- xDSL lines (retail + resale)
- xDSL contended Mbit/s (retail + resale)
- IPTV linear (retail subscribers)
- IPTV linear (retail Mbit/s/link)
- Business data connectivity (retail Mbit/s)
- VoD contended Mbit/s (retail)
- Other retail leased lines
- CPE and customer installations
- Network service provisioning/adaptations

⁴ **Carrier services** are the services supported by the network which are not sold on the retail market (e.g. sold to other local operators, international operators, un-bundlers etc.)

- Outgoing calls (wholesale)
- Regional incoming calls (wholesale)
- National incoming calls (wholesale)
- Regional transit calls (wholesale)
- National transit calls (wholesale)
- xDSL lines (unbundling subscribers)
- xDSL lines (bitstream subscribers)
- Business data connectivity (telecoms operators Mbit/s)
- xDSL unbundling (contended Mbit/s)
- IPTV linear (wholesale subscribers)
- IPTV linear (wholesale Mbit/s/link)
- Fibre (dark or wavelength)
- xDSL bitstream (contended Mbit/s)
- VoD wholesale (contended Mbit/s)
- Other wholesale leased lines (including internal leased lines for Belgacom operations)
- Co-location and ISLA
- Wholesale one-time fees

- a proportion of overheads costs (i.e. ‘pure’ overheads) are treated as common to network and retail activities.

The four cost elements that are treated as common costs are marked-up on an **equal percentage basis (i.e. EPMU)** to the constituent network services. The percentage is calculated from the IT and overheads cost calculation compared to Belgacom’s regulatory accounts.

Question 10.

Do you agree with the modelling of technical network cost components as entirely long-run variable costs?

Do you agree with the application of an EPMU for IT and pure overheads costs, calculated with reference to Belgacom’s total cost base (regulatory accounts)?

3 Calculation modules

This section outlines the scope of each module and lists the consultation questions for industry parties’ responses. It should be read in conjunction with the relevant sections of the accompanying documents:

- Presentation on behalf of BIPT, Draft NGN/NGA models, version updated for model release, 23 December 2011
- Report for BIPT, BIPT’s NGN/NGA model, Model version 1.0 documentation, 23 December 2011
- Bottom-up fixed network cost model for BIPT: list of model components, 23 December 2011.

3.1 Module 0: Market

This module calculates the demand for fixed services at the level of both the market and the modelled operator. The services being modelled at the operator level are listed below in Figure 3.1.

<i>Voice services</i>	<i>Broadband services</i>	<i>IPTV services</i>	<i>Business connectivity services</i>
On-net calls (retail)	xDSL lines (retail + resale subscribers)	IPTV linear (retail subscribers)	Fibre (dark or wavelength)
Outgoing calls to international (retail)	xDSL lines (unbundling subscribers)	IPTV linear (wholesale subscribers)	Business data connectivity (retail Mbit/s)
Outgoing calls to mobile (retail)	xDSL lines (bitstream subscribers)	IPTV linear (retail Mbit/s/link)	Business data connectivity (telecoms operators Mbit/s)
Outgoing calls to other fixed operators (retail)	xDSL retail + resale (contended Mbit/s)	IPTV linear (wholesale Mbit/s/link)	
Outgoing calls to non-geographical numbers (retail)	xDSL unbundling (contended Mbit/s)	VoD retail (contended Mbit/s)	
Outgoing calls (wholesale)	xDSL bitstream (contended Mbit/s)	VoD wholesale (contended Mbit/s)	
Regional incoming calls (wholesale)			
National incoming calls (wholesale)			
Regional transit calls (wholesale)			
National transit calls (wholesale)			

Figure 3.1: Fixed services modelled at the operator level [Source: Analysys Mason]

Question 11.	Do you agree with the list of services being modelled?
Question 12.	How do our forecasts compare with your own expectations of the market?
Question 13.	Do you have any other comments on this module?

3.2 Modules 1 + 2 + 3 + 4 + 6: Core

This module calculates the required number of core assets required to fulfil the service demand forecast in *Module 0: Market*. It then calculates the corresponding investment and operating costs and depreciates them using economic depreciation.

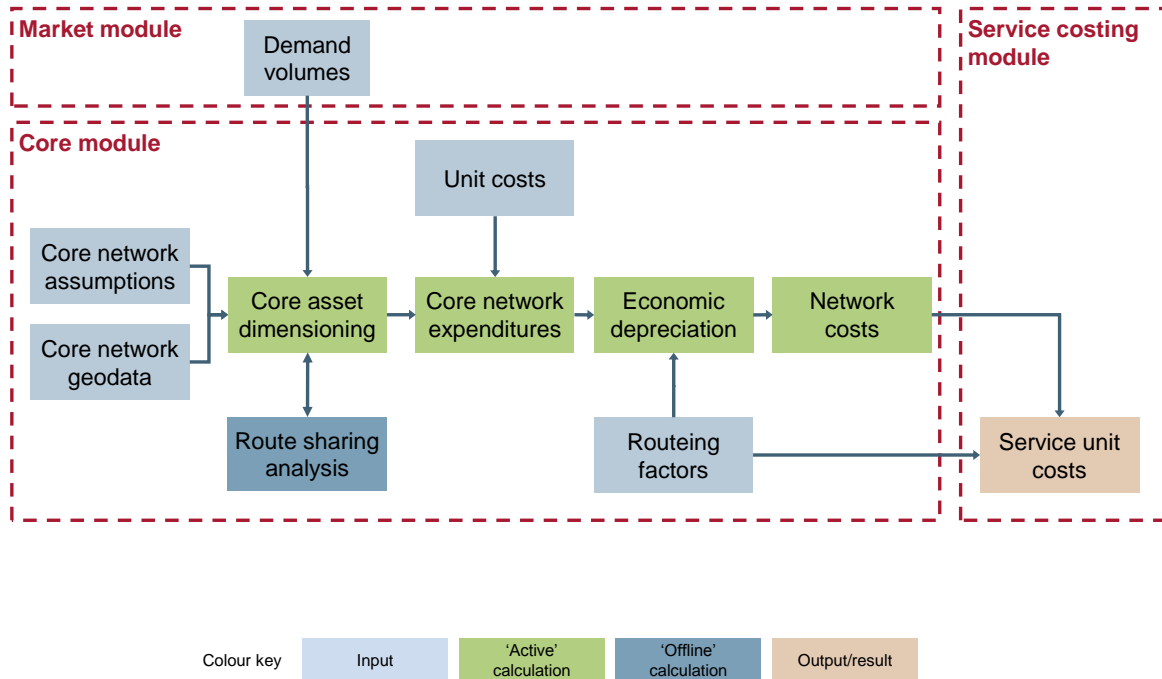

Figure 3.2: High-level flow of calculations in the core module [Source: Analysys Mason]

The operator modelled has the following characteristics:

- an Ethernet aggregation network
- an IP core network
- a mix of remote optical platform (ROP)-based and LEX-based IP digital subscriber line access multiplexers (DSLAM)
- a mix of ROP-based and LEX-based time division multiplexing (TDM)-IP access gateways (AGW) providing TDM to voice-over-IP (VoIP) conversion within the street cabinet or within the exchange
- a national dense wave division multiplexing (DWDM) transmission network.

The legacy voice, broadband and transmission platforms are not modelled and the corresponding services are replaced by their NGN/NGA equivalents.

The modelled Ethernet aggregation/IP core network is based on the reference architecture shown below in Figure 3.3.

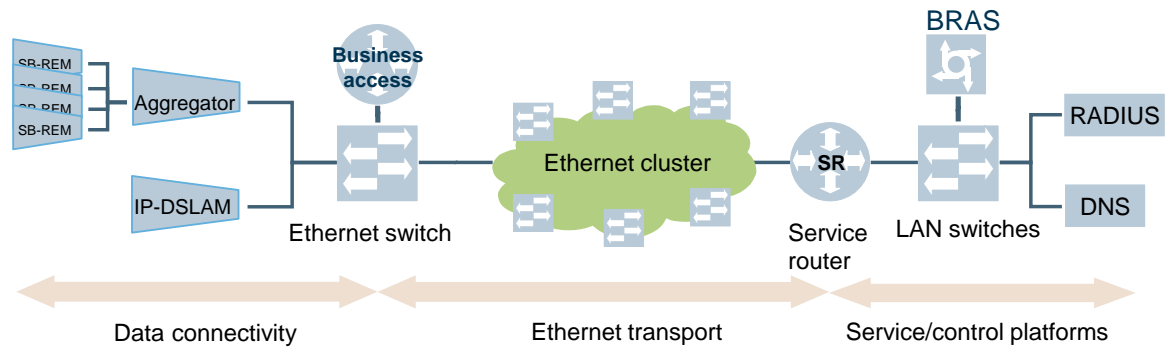

Figure 3.3: High-level Ethernet aggregation/IP core network architecture diagram [Source: Analysys Mason]

An IP multimedia subsystem (IMS) overlay is added on top of the Ethernet aggregation/IP core network to support NGN voice and IPTV services, as shown in Figure 3.4.

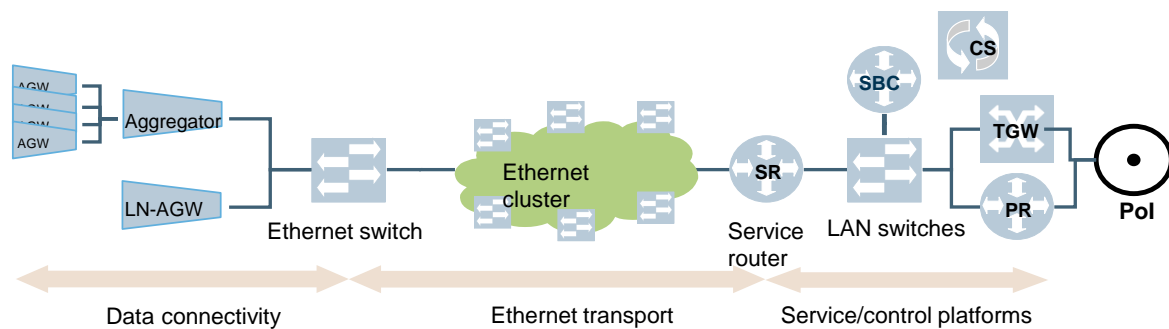
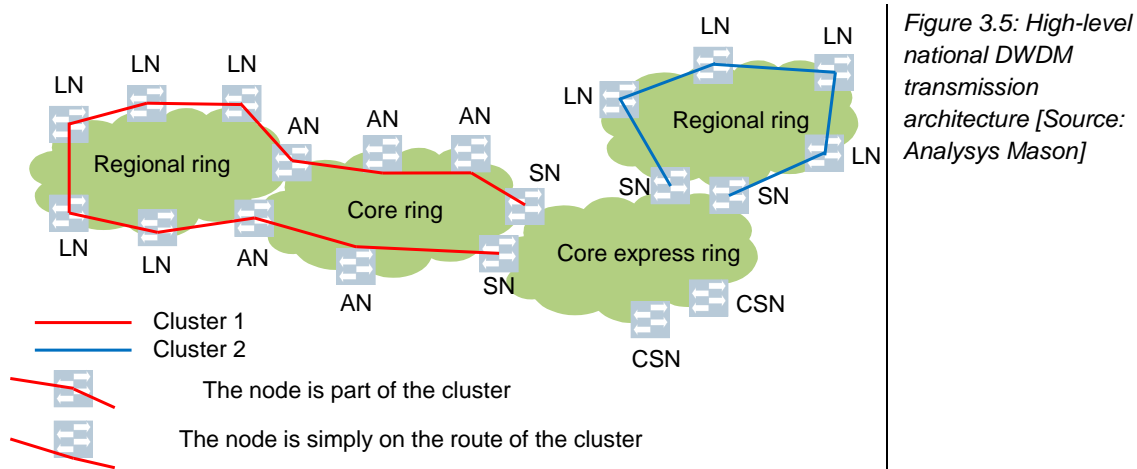

Figure 3.4: Illustration of a high-level next-generation core network architecture [Source: Analysys Mason]

The model is able to consider three cases for voice interconnection: 5+5, 5+1 or 1+1 points. We also model a migration between SS7 and SIP interconnection.

<p>Question 14.</p>	<p>Do you agree that the architecture described above represents a modern architecture for an integrated NGN operator? If not, please indicate how this should be modified in your opinion.</p>
<p>Question 15.</p>	<p>What is the efficient interconnection point architecture for Belgium?</p> <p>What is the efficient protocol (SS7 or SIP) for voice interconnection, recognising that it may be reasonable for there to be a migrating share of interconnection by protocol over time?</p>

The national DWDM transmission network is made up of resilient fibre rings at three levels, as shown below in Figure 3.5.



The trench carrying the national DWDM transmission fibre cables is assumed to be shared between the different levels of core networks and between the core and the access network. Figure 3.6 shows the results of the analysis of the trench sharing between the different levels of core networks.

Network layer	Physical rings	Links	Dedicated cable (km)	Incremental trench (km)	Fibre regenerators
Regional	62	611	4453	4453	-
Core normal	7	137	1200	605	-
Core express	2	50	688	80	3
Total	71	798	6340	5138	3

Figure 3.6: Results of the analysis of the trench sharing between the different levels of core networks [Source: Analysys Mason]

Figure 3.6 shows straight-line distances in the modelled network. In reality, route distances would not be straight lines (e.g. 1.2 times the straight-line distance).

Question 16. What is a realistic multiplier for actual distances compared to straight-line distances in Belgium?

We have calculated the length of core routes within various distances of the access nodes (0km, 0.5km, 1km, 1.5km, 2km). We assume that a 2km sharing from the access node is efficient. These parts of the core routes are assumed to share the trenches dug for the access network. The avoided trench cost is then shared equally between the access and the core cost modules.

Question 17. Do you agree that the trench sharing being modelled is representative of what an efficient operator would be doing?

The modelled operator deploys its network in stages based on the schedule shown in Figure 3.7.

<i>Equipment category</i>	<i>Deployment schedule</i>
Ethernet switches/IP routers	Entirely deployed in 2005 (for all geotypes)
IP DSLAMs in LEX and local distribution cabinets (LDC)	Entirely deployed in 2005 (for all geotypes)
AGW in LEX and LDCs	Deployed from 2009 for all geotypes; all deployed by 2011 so the model can calculate a cost for voice-regulated services for 2011 onwards
ROPs and shelf-based remote DSLAMs (SB-REM)	Deployed from 2005 Geotype S1, geotype S2 and geotype S3 fully deployed by 2008, to match at this date the number of ROPs deployed in the Belgacom Reference Unbundling Offer (BRUO)/Belgacom Reference Offer for Bitstream Access (BROBA) model Geotype S0+ deployed from 2009
AGWs in ROPs	Deployed from 2009 in pre-existing and new ROPs From 2011 all existing ROPs have been retrofitted with AGWs and all new ROPs are deployed with an AGW

Figure 3.7: Network equipment deployment schedule [Source: Analysys Mason]

Question 18.	Do you agree that the schedule described above is representative of what an efficient operator would be doing?
---------------------	--

Figure 3.8 below shows the main assumptions used in this module.

<i>Key assumptions</i>	<i>Value</i>
Proportion of voice traffic staying in the same region (model assumes five regions in line with the new announcements by Belgacom)	80%
Proportion of data business connectivity (i.e. Ethernet virtual private networks or VPNs) staying in the same region	20%
Bandwidth occupied per voice call transported as VoIP	95kbit/s
Percentage of traffic in the busy hour	8–10%
Unit capex in 2011	See cells V38:V137 in sheet 'AssetIn'
Unit capex cost trends	See rows 16-30 in sheet 'CostTrends'
Annual maintenance events	See rows 23-36 in sheet 'UnitOpex'
Floor space requirements per equipment	See cells B464:B563 in sheet 'UnitOpex'

Figure 3.8: Key assumptions used in the core model [Source: Analysys Mason]

Question 19.	Please provide comments on the key assumptions listed in Figure 3.8 or any other parameters/inputs you think require adjusting. Please provide justifications in each case.
Question 20.	Do you have any other comments on this module?

3.3 Modules 5 + 7: Access

This module calculates the expenditures and annualised total/service costs of the various access network elements over the full time period access operations. The scope of the module is illustrated below in Figure 3.9.

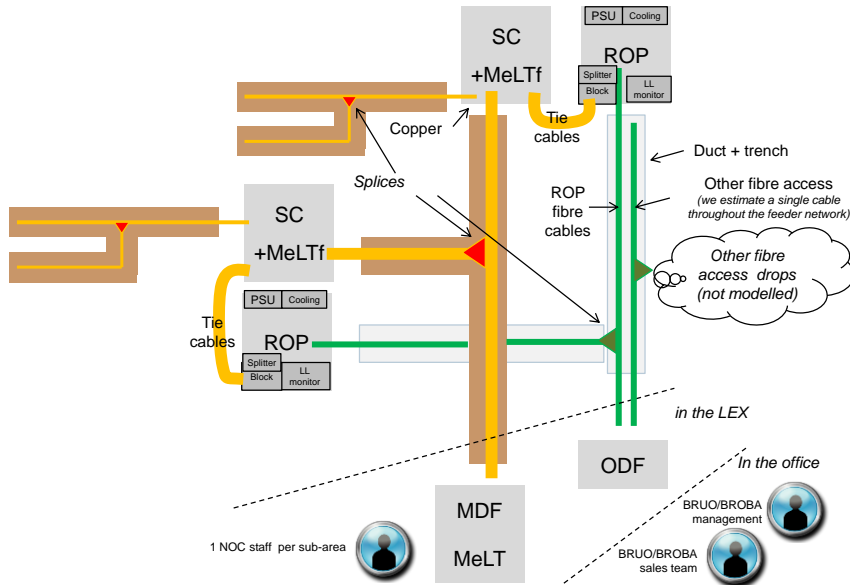

Figure 3.9: Scope of the access module [Source: Analysys Mason]

Question 21.

Please provide comments on the scope of the access module?

Do you consider that additional network elements should be modelled?

The model starts in the late 1960s when the existing copper access public switched telephone network (PSTN) commenced its roll out, and calculates the unit costs of the services provided on the network until 2050. Some access network assets are removed from the calculation before 2050, whereas other assets persist for the full duration.

We model a copper access distribution network that takes 25 years to roll out (1967 to 1991). From 1991 onwards, the copper access network is then expanded to connect new households as the number of households in Belgium slowly increases. We assume that the copper network is replaced by nationwide FTTH and deactivated area-by-area from 2017 to 2037.

We model the deployment of street cabinets and the copper feeder network from 1977 onwards, when the copper network is extending further from the LEX areas. While street cabinets are steadily removed in line with the decommissioning of the copper distribution network, we assume that the copper feeder is de-commissioned in 2015 (the year when we assume that all street cabinets have a remote optical platform with a VoIP access gateway). The deployment of remote optical equipment, feeder trenches, feeder fibre and FTTO fibre cables starts in 2005, and these network elements are operated and replaced in perpetuity until the end of the modelled period.

An FTTH access network is not modelled.

Question 22.	<p>Do you agree with the timescales over which different access network elements are assumed to be active in the network?</p> <p>Do you agree with modelling the copper access network from the late 1960s?</p> <p>What is your opinion on the modelling of a shut-down of copper distribution to be implicitly replaced by FTTH?</p>
---------------------	---

We have used the number of starting points for the access module that are based on previous efficient bottom-up network modelling carried out by BIPT. Deployment drivers are used to scale up the deployment of access network elements over time (e.g. household growth, street cabinet roll-out, FTTO take-up). Network elements are purchased and operated over time; some network elements are modelled with a recurring replacement lifetime; other network elements are only modelled once (e.g. copper access cables).

Question 23.	<p>Please provide comments on the efficient deployment and dimensioning of the access network elements.</p>
---------------------	---

Unit costs for capex (installation and materials separately) and opex (maintenance events, replacement materials and technical network space) are defined for each network element. We apply long-run cost trends to the capex and opex calculations, and include an ‘exceptional’ cost trend for copper in the period 2005–2009. This exceptional cost trend for copper only affects the expenditures coming into the model; it is not applied as a cost trend in the economic depreciation annualisation (because this cost trend does not reflect the modern equivalent asset (MEA) price trend in these years). We assume that 50% of copper distribution trenches are free from the year 2000 (being paid for by the house builder), and 100% are free from 2017 onwards (being paid for by FTTH).

We bring the number and unit cost of small network adaptations (SNA) into the access network module. These inputs are then used to calculate the cost per line for SNA activities.

Question 24.	<p>Please provide comments on the expenditure inputs and calculations of the access module.</p> <p>Please also comment on the treatment of SNA costs in the access module, leading to a calculation of the cost per line.</p>
---------------------	---

All network elements are assumed to have an ‘output profile’ which defines how many units of output are generated (e.g. number of active lines of different types). These output profiles are used in the economic depreciation calculation to calculate annualised costs per network element per line. After this step, a set of routing factors build up the usage of different network elements for each access network service. The access network services include local loop unbundling (LLU), sub-loop unbundling (SLU), passive parts for VDSL, SNA, etc.

Question 25.	Do you agree with the access network services being modelled? Please also provide comments on the output profiles and service routing factors used to define the build-up of the access network services?
Question 26.	Do you have any other comments on this module?

3.4 Module 8: Various colocation calculations

This module produces updated values for colocation unit costs.

BIPT has a series of detailed colocation models:

- three activity models for upfront and recurring administrative costs
- one asset model for upfront and recurring power costs
- one composite floor space model taking into account real-estate management costs (e.g. rent, tax), facility management (e.g. security equipment) and costs directly related to colocation services (e.g. cost of the National Wholesale department).

The models (and their supporting assumptions) were described in detail in BIPT’s decision of 25 June 2008 regarding colocation tariffs.

We have updated these models with:

- new hourly manpower charge
- new IT and overheads mark-ups for indirect allocations
- updated building-related costs
- updated power-related inputs (energy consumption, power equipment costs, power equipment footprint, cooling consumption, costs of maintenance).

Question 27.	Please provide information on your own building costs: <ul style="list-style-type: none"> • rental costs • taxes • facility management (improvements, fittings, security) • other.
Question 28.	Do you have any other comments on this module or its results?

3.5 Module 9: SNA

The small network adaptation (SNA) calculation module contains a number of confidential inputs from Belgacom. As a result, the information included in the accompanying consultation slide packs (referred to at the beginning of Section 3) is the object of consultation for this module. In addition, there are a number of key numerical inputs on which consultation input is requested.

Question 29.	Do agree with the three types of SNA modelled, and how they are assigned to new households compared to VDSL upgrades?
Question 30.	Do you agree with the assumption that VDSL-related SNAs will cease once the VDSL subscriber base upgrade is largely complete, and with the assumed percentage of line upgrades which will need SNA?
Question 31.	How long does it take to connect a network termination point (NTP) to the end of the copper pair cable? How long does it take to install the NTP ‘in-situ’ (e.g. drilling into wall, cable clips)?
Question 32.	How large (area and depth) is the average street pit needed to splice to a single distribution cable? How large (area and depth) is the average street pit needed to splice from one distribution cable to a second distribution cable in the same street?
Question 33.	Do you have any comments on the <i>cost</i> calculations applied to give the per-line <i>cost</i> for SNAs?
Question 34.	Do you have any other comments on this module?

3.6 Module 9: Updated one-time fees

The one-time fees cost calculation is based upon many of Belgacom’s internal activity-based processes and costs. As a result, this module contains largely confidential business and engineering values. The results from the one-time fees calculations (provided in Annex A) are therefore the main subject of consultation in this module, along with a number of specific input values. These input values are explained below.

3.6.1 Vehicle costs

Each hour of network technician work (e.g. time to travel, time spent at premises, time spent at street cabinet) is supported by vehicle costs.

Question 35.	What is the annual cost per technical network vehicle? How many hours of technical work can be supported by one vehicle?
---------------------	---

3.6.2 Un-attributed wholesale department staff

The number of wholesale events is multiplied by the per-event amount of work time for the wholesale department. This gives the number of *FTEs fully engaged in one-time fees activities*.

In the Belgacom activity-based costing, the number of *FTEs fully engaged in one-time fee activities* is increased by a ‘mark-up’ to account for other directly involved wholesale department staff who are supporting the *FTEs fully engaged in one-time fee activities*. These *other directly involved* staff are defined as ‘un-attributed’.

‘Un-attributed’ wholesale department staff are then assigned to the allocated (fully engaged) FTEs on a pro-rata basis.

Question 36.	What is the efficient ratio for the number of ‘un-attributed’ wholesale department staff (e.g. management team) compared to attributed wholesale department FTEs who would be fully engaged in wholesale activities for OLOs?
---------------------	---

3.6.3 Copper line activities

A number of the one-time fee calculations rely on Belgacom’s conducting a sequence of copper main distribution frame (MDF) jumpering and line testing activities, using the time estimates shown in Figure 3.10 below.

<i>Time (minutes)</i>	<i>Activity</i>
5	Installation of jumper between vertical OLO dedicated block and horizontal Belgacom block connected to switch
2	Dejumpering between vertical OLO dedicated block and horizontal Belgacom block connected to switch
5	Installation of jumper between vertical OLO dedicated block and vertical Belgacom block
2	Dejumpering between vertical OLO dedicated block and vertical Belgacom block
5	Installation of jumper between horizontal OLO dedicated block and vertical Belgacom block
2	Dejumpering between horizontal OLO dedicated block and vertical Belgacom block
2	Dejumpering between horizontal BGC block and vertical Belgacom block
5	Dejumpering between horizontal BGC block and vertical Belgacom block
10	VDSL test with line/signal testing tool: test attenuation of new frequencies

Figure 3.10: Copper line activities [Source: One-time fees calculations]

Question 37.	Do you have any comments on the time taken to conduct the listed copper line activities?
---------------------	--

3.6.4 Un-billed orders

Belgacom commences one-time fee activities for some situations, often product migrations, which do not end up with the successful initiation of network activities:

- in some cases, the initial work order validation reveals a ‘no-go’ for the migration request (around 30–40% of requests)
- in some cases, after various investigations, the migration request turns out to be technically impossible (less than 5% of requests).

Belgacom incurs administrative and planning costs up to the point that the network activity is initiated.

In the one-time fee calculation, these administrative and planning costs are re-attributed to successful events. In some migration cases, there are two order validations (physical migration BROBA without voice and physical migration to raw copper).

Question 38.	What is your opinion on the number and causes of un-billed requests?
Question 39.	Do you agree with the treatment of the costs for un-billed orders, and that some order types entail additional validations?
Question 40.	Do you have any other comments on this module?

3.7 Module 14: Improved service level agreements (ISLA)

Modules 1 + 2 + 3 + 4 + 6: Core and Modules 5 + 7: Access include the costs associated with the network management system (NMS) and network operating control (NOC) staff required to operate and monitor the network during normal business hours. In addition, the opex unit cost for each of the elements in the core and access network includes the costs associated with a certain amount of maintenance each year.

This module calculates the additional costs associated with operating and monitoring the network 24/7 instead of during normal business hours. The additional costs come from three main sources:

- labour resource dedicated to ISLA trouble tickets (TT) during normal business hours
- labour resource outside normal business hours – dedicated to ISLA TTs by definition
- additional liability costs due to strengthened financial penalties in case of breach of the ISLAs.

This module takes into account the first two sources of costs described above. This calculation is based on data provided by Belgacom on the number of staff required to operate and monitor the network 24/7 and to solve the expected number of ISLA TTs. While the actual data provided by Belgacom is confidential, Figure 3.11 shows some of the ratios and metrics suggested by the said data.

<i>Metric</i>	<i>Value implied</i>	<i>Comment</i>
FTE helpdesk hours per TT	Between 4 and 5 hours	Based on data provided by Belgacom on the number of FTEs and annual TT volumes. It assumes a total of 1725

		working hours per annum
Number of FTEs employed to supply one out-of-hours shift of 16 hours each night	5	This defines the shift pattern needed to have one FTE of cover working out of hours for an annual period
Increase in shift wages	25%	-

Figure 3.11: ISLA implied metrics and ratios [Source: Analysys Mason]

Question 41. Please indicate whether the metrics above are indicative of an efficient NGN operator? If not, please suggest alternative values and provide the rationale for such a change – e.g. your own number of support employees.

An annual cost per line is calculated by estimating the average cost per trouble ticket and the proportion of access lines that have a trouble ticket per annum (whether basic SLA or ISLA): multiplying both numbers by each other gives an average ISLA servicing cost per annum per access line.

This calculation is done separately for business-oriented access lines (mainly SDSL) and residential-oriented access lines (other lines). The difference in the average cost per line reflects the difference in the proportion of access lines that have a trouble ticket per annum.

The TT rate per line per annum assumed in the calculations is:

- business-oriented line approximately 10%
- residential-oriented line approximately 1%.

Question 42. Do you consider that the assumed TT rates per line reflect an efficient NGN operator? If not, please suggest alternative values with supporting justification.

This module does not take into account the final source of ISLA costs, i.e. additional liability costs, as this is a ‘cost’ not associated with the actual cost of fulfilling the ISLA but with the financial penalties in case of breach of the ISLAs. It can therefore be seen as more of an insurance premium, i.e. if OLOs want higher financial penalties in case of breach of the ISLAs, then they should expect a higher average cost for the ISLAs (as an efficient operator would employ more ISLA support staff to balance the risk of incurring larger penalties in the case of service-level breach).

Question 43. Do you have any view on the impact of financial penalties on the costs of ISLAs?
Do you have any data on the probability of breach of the ISLAs?
What levels of financial penalties are appropriate in your opinion? Why?

Question 44. Do you have any other comments on this module?

3.8 Module 15 + 16 + 17: HMC, IT and OH

These modules are used to build up the manpower, IT and overheads-related costs for network activities; the complete Excel file supplied to BIPT and Belgacom contains confidential wage information and other business costs from Belgacom. The following numerical values are used in these modules and are the subject of the consultation in these modules.

3.8.1 HMC

Please provide comments on the following key inputs, reflecting the year 2009:

- 1725 employed hours per annum based on 7.5 hours per day and 30 days public/private holiday
- average annual salary of a network engineer divided by employed hours (Statbel 2008 provides comparable sector wage rates of around EUR30 to EUR36 per hour).⁵
- average annual salary of a wholesale department employee, divided by employed hours (Statbel 2008 provides comparable sector wage rates of between EUR30 and EUR53 per hour)
- a 10% allowance for absence, time spent on training course, and scheduled work breaks, excluding lunchtime
- annual indexation of wage rates per hour of work, over the long term, by general inflation.

Please submit your response for the following key inputs, reflecting the year 2009:

- the amount of outsourced labour utilised per hour of in-house labour, split if possible for passive network equipment, active network equipment, and civil works.

Question 45.	Please provide any comments on the key inputs listed above.
Question 46.	Do you have any other comments on this module?

3.8.2 IT

Please provide comments on the following key inputs, reflecting the year 2009:

- average annual salary of an IT department worker, divided by employed hours (Statbel 2008 provides comparable sector wage rates of around EUR44 per hour)
- floor space per server: 2m² for a small server (e.g. Windows server) and 4m² for a large server (e.g. mainframe).

Please submit your response for the following key inputs, reflecting the year 2009:

- the ratio of IT department full-time employees (FTE) compared to the number of physical IT servers
- the ratio of outsourced FTEs compared to in-house FTEs

⁵ <http://statbel.fgov.be/>.

- the ratio of maintenance, consulting and other direct IT costs compared to direct IT department FTE wage costs
- the ratio of software asset value compared to hardware asset value (gross book value – GBV – or gross replacement value – GRC)
- the lifetime of hardware and software assets in the IT department
- the split of the costs of IT department functions, as shown in Figure 3.12, with supporting departmental timesheet information and server pool functional processing requirements relating to different IT project workloads in the retail, overheads and network areas.

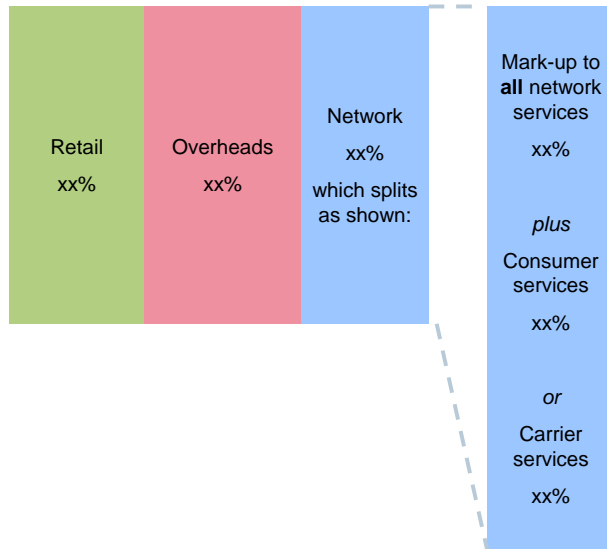

Figure 3.12: IT department split
[Source: Analysys Mason]

- the ratio of the total costs of the IT department compared to the total costs of the rest of the business (network plus retail plus overheads activities).

Question 47.	Please provide any comments on the key inputs listed above.
Question 48.	Do you have any other comments on this module?

3.8.3 Overheads

Please provide comments on the following key inputs, reflecting the year 2009:

- average annual salary of staff in the ‘pure’ overheads department (communications, finance, head office, legal, secretariat, strategy), divided by employed hours (Statbel 2008 provides comparable sector wage rates for management boards of around EUR59 per hour)
- the ratio of the cost of training and medicals, compared to annual salary (Statbel 2008 provides comparable ratios of around 1.2%)
- 20m² office space plus 7.5m² parking space per FTE
- EUR50 annual rental (before tax) per square meter of office space, before fixtures, fittings or technical facilities
- 7.5% rental taxes in addition to annual rent

- an annual cost per square meter for all office fixtures, electricity, security, etc. (approx. <100 EUR/m²)
- an additional annual cost per square meter for all power, back-up, air conditioning and fit-out of technical building space, electricity security, etc. (approx. <400 EUR/m²)
- the proportion of network work⁶ that is ‘utility’ work compared to ‘desk-based’ work (estimated at 50% each).

Please submit your response for the following key inputs, reflecting the year 2009:

- the ratio of the cost of bonus payments to staff compared to their annual salary
- the ratio of human resource FTE compared to total FTE in all other departments
- the cost of expensed tools and vehicles for network utility activities, compared to annual salary for network utility work
- the cost of expensed tools and vehicles for desk-based network activities, compared to annual salary for network desk work
- the ratio of the total costs of the ‘pure’ overheads department compared to the total costs of the rest of the business.

Question 49.	Please provide any comments on the key inputs listed above.
Question 50.	Do you have any other comments on this module?

3.9 Module 20 + 21 + 22 + 23: Service costing

The service costing module performs a number of calculations and builds up the ultimate regulated services from constituent network components. This file also adds the relevant IT and overheads mark-ups to the resulting service costs. The calculations in this module show the final cost results of the bottom-up model – they do not yet represent prices (which will be defined by BIPT as part of its price-setting activities).

Question 51.	Do you have any comments on this module?
---------------------	--

3.10 Module 13: CPE

The customer premises equipment (CPE) module does not exist in Excel form. Instead, the accompanying documentation presents our estimates of the costs incurred by network operators in 2011 for a variety of customer equipment types purchased from the original equipment

⁶ We define two types of network work: *utility* work and *desk-based* work. This split is used to define whether hourly manpower costs include the cost of network utility vehicles owned or operated by Belgacom (vans, hoists, excavators, etc.).

- **utility work** is carried out in the field: in the street, in the un-manned exchange or LDC, in the customer premises, etc.
- **desk-based work** is carried out in the departmental office, network operations centre, network management facility or manned exchange building.

manufacturer (OEM) or from the in-country equipment distributor, and our expectations for the trend in this cost for the next few years.

<i>Question 52.</i>	Do you have any comments on the CPE costs and trends presented in this module?
<i>Question 53.</i>	Do you have any other comments on this module?

4 Responding to this consultation

Responses to this consultation should be sent to BIPT by [date to be confirmed].

Responses should be in French, Dutch or English, with a preference for English.

Please provide as much supporting evidence and justification for your answers as possible, rather than simple yes/no replies.

Questions should be sent to BIPT [details to be confirmed].

Annex A Draft numerical results

As shown in Figure 1.1, BIPT and Belgacom have access to the complete draft bottom-up cost model. As such, BIPT and Belgacom can observe the full calculations which give rise to the exact draft results.

On the other hand, other industry parties have not been sent the full details of the draft cost model in order to protect Belgacom's detailed confidential numerical information – these cost model inputs have not been distributed, or have been numerically 'rounded'. Therefore, these industry parties cannot observe the exact calculation of the draft results in the model they will receive.

Annex B Glossary of terms

AGG-AGW:	Access gateway aggregator
AGW:	Access gateway
AN:	Access node
BIPT:	Belgium Institute for Postal Services and Telecommunications
BRAS:	Broadband remote access server
BROBA:	Belgacom Reference Offer for Bitstream Access
BRUO:	Belgacom Reference Unbundling Offer
CPE:	Customer premises equipment
CS:	Call server
CSN:	Central service node
DNS:	Domain name system
DSL:	Digital subscriber line
DSLAM:	Digital subscriber line access multiplexer
DWDM:	Dense wave division multiplexing
EC:	European Commission
ED:	Economic depreciation
EU:	European Union
EPMU:	Equi-proportionate mark-up
FTE:	Full time equivalent
FTTC:	Fibre to the cabinet
FTTH:	Fibre to the home
FTTO:	Fibre to the office
GBV:	Gross book value
GRC:	Gross replacement cost
HCA:	Historical cost accounting
HFC:	Hybrid fibre coaxial
HMC:	Hourly manpower cost
HVAC:	Humidity ventilation air conditioning
IMS:	IP multimedia subsystem
IP:	Internet protocol
IPTV:	Internet protocol television
ISLA:	Improved service level agreement
IT:	Information technology
LAN:	Local area network
LDC:	Local distribution cabinets
LEX:	Local exchange
LEX-AGW:	AGW located in the LEX
LL:	Leased line
LLU:	Local loop unbundling
LN:	Local node
LRAIC:	Long-run average incremental cost
LRIC:	Long-run incremental cost
MEA:	Modern equivalent asset

MeLT:	Metallic line testing
MeLTf:	Metallic line testing functionality present in the ROPs
MDF:	Main distribution frame
NGA:	Next-generation access
NGN:	Next-generation network
NMS:	Network management system
NOC:	Network operating control
NTP:	Network termination point
ODF:	Optical distribution frame
OEM:	Original equipment manufacturer
OH:	Overhead
OLO:	Other licenced operator
PoI:	Point of interconnection
PR:	Peering router
PSTN:	Public switched telephone network
PSU:	Power supply unit
RADIUS:	Remote authentication dial-in user service
ROP:	Remote optical platform
ROP-AGW:	AGW located in the ROP
SBC:	Session border controller
SB-REM:	Shelf-based remote DSLAM
SC:	Street cabinet
SIP:	Session initiation protocol
SLA:	Service level agreement
SLU:	Sub-loop unbundling
SN:	Service node
SNA:	Small network adaptation
SR:	Service router
SS7:	Signalling system 7
TDM:	Time division multiplexing
TGW:	Transit media gateway; trunk gateway
TT:	Trouble ticket
VDSL:	Very high-rate Digital Subscriber Line
VoD:	Video on demand
VoIP:	Voice over Internet protocol
VPN:	Virtual private network
WACC:	Weighted average cost of capital
xDSL:	Generic term for DSL

