

**B I P T**

---

**BELGISCH INSTITUUT VOOR POSTDIENSTEN  
EN TELECOMMUNICATIE**

**ONTWERPBESLUIT VAN DE RAAD VAN HET BIPT  
VAN 15 MEI 2012  
BETREFFENDE  
HET REFERENTIEAANBOD  
AANGAANDE HET MULTICAST-ALTERNATIEF**

Werkwijze om reacties op dit document door te sturen

Antwoordtermijn: 14 juni 2012  
Aanspreekpunt: Thomas Gille, ingenieur-adviseur (02 226 88 55)  
Antwoordadres per e-mail: [Thomas.gille@bipt.be](mailto:Thomas.gille@bipt.be)

Antwoorden dienen elektronisch te worden verzonden.  
Op het document moet duidelijk worden aangegeven wat vertrouwelijk is

## Inhoudsopgave

<b>1</b>	<b>INLEIDING</b> .....	<b>3</b>
<b>2</b>	<b>PROCEDURE</b> .....	<b>4</b>
2.1	VERLOOP VAN DE PROCEDURE .....	4
2.2	NATIONALE RAADPLEGING.....	4
2.2.1	<i>Wettelijke basis</i> .....	4
2.2.2	<i>Synthese van de reacties</i> .....	5
2.3	DE RAADPLEGING VAN DE MEDIAREGULATOREN.....	5
2.3.1	<i>Wettelijke basis</i> .....	5
2.3.2	<i>Resultaten van de raadpleging van de mediaregulatoren</i> .....	6
2.4	DE EUROPESE RAADPLEGING.....	6
2.4.1	<i>Wettelijke basis</i> .....	6
2.4.2	<i>Werkwijze en resultaten van de Europese raadpleging</i> .....	7
<b>3</b>	<b>REGLEMENTAIR KADER</b> .....	<b>8</b>
3.1	WETGEVING.....	8
3.2	HET MARKTANALYSEBESLUIT VAN 1 JULI 2011 .....	9
<b>4</b>	<b>ANALYSE VAN HET REFERENTIEAANBOD</b> .....	<b>13</b>
4.1	ONTBREKENDE ELEMENTEN .....	13
4.1.1	<i>Fast channel zapping &amp; retransmission</i> .....	13
4.1.2	<i>Hergebruik tv streams voor premium services</i> .....	15
4.1.3	<i>Dekking &amp; beschikbaarheid van aantal SD/HD streams</i> .....	18
4.2	TRANSPARANTIE OVER DE EVOLUTIE VAN HET AANBOD.....	19
4.2.1	<i>Toevoegen van een zender aan het gemeenschappelijk zenderaanbod</i> .....	19
4.2.2	<i>Verwijderen van een zender uit het gemeenschappelijk zenderaanbod</i> .....	20
4.2.3	<i>Beschikbare capaciteit voor toegewijde zenders</i> .....	22
4.2.4	<i>Aanpassingen die een impact hebben op de firmware van de decoders</i> .....	23
4.2.5	<i>Sluiting van de centrales</i> .....	25
4.3	DE IMPLEMENTATIE VAN HET AANBOD .....	26
4.3.1	<i>Timing</i> .....	26
4.3.2	<i>Activatie van multicast aanbod &amp; XML Description</i> .....	27
4.3.3	<i>Documenten op de beveiligde website</i> .....	28
4.4	DETAILOPMERKINGEN OVER HET REFERENTIEAANBOD .....	28
4.4.1	<i>Annex 1 – General Terms &amp; Conditions</i> .....	28
4.4.2	<i>Annex 2 – Technical Specifications</i> .....	29
4.4.3	<i>Annex 3 – P&amp;O</i> .....	30
4.4.4	<i>Annex 4 – Service Level Agreements</i> .....	30
<b>5</b>	<b>BESLUIT</b> .....	<b>32</b>
<b>6</b>	<b>BEROEPSMOGELIJKHEDEN</b> .....	<b>33</b>

## 1 INLEIDING

1. Op 1 juli 2011 heeft de Conferentie van Regulators voor de elektronische communicatiesector (CRC) een beslissing genomen met betrekking tot de analyse van de breedbandmarkten<sup>1</sup>. In deze beslissing worden een aantal maatregelen opgelegd aan de operator met een sterke machtspositie, namelijk Belgacom. Eén van deze maatregelen is de invoering van een nieuwe toegangsverplichting betreffende de multicastfunctie. Hierin staat ook dat Belgacom het recht heeft om een alternatief voorstel in te dienen voor de multicastfunctie.
2. Belgacom heeft bij schrijven van 19 september 2011 een voorstel ingediend bij het BIPT waarbij het een type wholesaledienst ontwikkelt dat een alternatief voorstel vormt voor multicast.
3. In het besluit van 4 januari 2012 heeft het BIPT dit alternatief voorstel goedgekeurd:

*« Gezien de mogelijkheden die het alternatieve voorstel biedt en de snelheid waarmee deze oplossing geïmplementeerd kan worden, is het BIPT van oordeel dat dit voorstel, namelijk de toegang tot een IPTV-platform als een alternatief voor multicast, kan worden goedgekeurd. Bijgevolg moet Belgacom deze oplossing verder uitwerken tot een volwaardig product dat opgenomen wordt in een aanpassing van het referentieaanbod binnen het tijdsschema vooropgesteld in de CRC-beslissing van 1 juli 2011<sup>2</sup>. Het BIPT verwacht dus een voorstel tot aanpassing van het referentieaanbod van Belgacom binnen twee maanden na de publicatie van dit besluit. »<sup>3</sup>*

4. Belgacom heeft op 6 maart 2012 een voorstel tot referentieaanbod aan het BIPT overgemaakt. In het aanbod van Belgacom wordt het IPTV-platform van Belgacom gedeeld voor broadcast, terwijl de OLO's vrij kunnen kiezen over alles inzake VoD, interactiviteit, de settopboxen met hun middleware alsook de verdeling van de sleutels.
5. Dit besluit heeft als doel de kwalitatieve aspecten van het voorgestelde referentieaanbod te evalueren.

---

<sup>1</sup> <http://www.bipt.be/ShowDoc.aspx?objectID=3540&lang=nl>

<sup>2</sup> Beslissing van de CRC van 1 juli 2011 met betrekking tot de analyse van de breedbandmarkten, r.o. 1109, 326-327.

<sup>3</sup> Paragraaf 50 van het [Besluit van de Raad van het BIPT van 4 januari 2012 betreffende de goedkeuring van het aanbod dat Belgacom als alternatief voorstelt voor de "multicast"-remedie](#), 21.

## 2 PROCEDURE

### 2.1 VERLOOP VAN DE PROCEDURE

6. Belgacom heeft op 6 maart 2012 een voorstel tot referentieaanbod aan het BIPT overgemaakt.
7. Het BIPT heeft op 16 maart 2012 een pre-consultatie gelanceerd die geduurd heeft tot 30 maart 2012. EDPNet en Mobistar hebben hun reacties op dit voorstel aan het BIPT overgemaakt.
8. Het BIPT heeft op 28 maart 2012 en 12 april 2012 met Belgacom een vergadering belegd om het voorstel van Belgacom en de verschillende reacties te bespreken.
9. Naar aanleiding van preliminaire opmerkingen van het BIPT heeft Belgacom op 7 mei 2012 op eigen initiatief reeds enkele wijzigingen aangebracht aan haar voorstel (zie bijlage).
10. De huidige raadpleging neemt deze wijzigingen reeds in aanmerking.

### 2.2 NATIONALE RAADPLEGING

#### 2.2.1 Wettelijke basis

11. De raadpleging wordt georganiseerd krachtens de artikelen 139 en 140 van de wet van 13 juni 2005 betreffende de elektronische communicatie:

*« Art. 139. Het Instituut kan voor de toepassing van deze wet een openbare raadpleging houden overeenkomstig artikel 14 van de wet van 17 januari 2003 met betrekking tot het statuut van de regulator van de Belgische post- en telecommunicatiesector. »*

*« Art. 140. Voorzover een ontwerpbeslissing van het Instituut aanzienlijke gevolgen zou kunnen hebben voor een relevante markt, organiseert het Instituut een voorafgaande openbare raadpleging met een maximale tijdsduur van twee maanden, met inachtneming van de regels inzake vertrouwelijkheid van de bedrijfsgegevens. Alle inlichtingen in verband met aan de gang zijnde openbare raadplegingen worden bij het Instituut gecentraliseerd. De resultaten van de openbare raadpleging worden openbaar gemaakt, met inachtneming van de regels inzake vertrouwelijkheid van de bedrijfsgegevens. De Koning bepaalt, na advies van het Instituut, de nadere regels van de openbare raadpleging en van de bekendmaking van de resultaten ervan. »*

12. In de beslissing van de CRC van 1 juli 2011 met betrekking tot de analyse van de breedbandmarkten staat in § 1109 vermeld dat het BIPT een besluit zal nemen aangaande het referentieaanbod dat Belgacom moet voorstellen indien het alternatieve voorstel aangaande de multicastfunctie goedgekeurd wordt.

*« Binnen 2 maanden na de goedkeuring van dit alternatief door het BIPT moet Belgacom aan het BIPT een voorstel tot aanpassing van het referentieaanbod bezorgen. Het BIPT zal vervolgens een of meer besluiten aannemen met betrekking tot de kwalitatieve en kwantitatieve aspecten van het voorstel voor een referentieaanbod van Belgacom. Het referentieaanbod in verband met het voormelde alternatief voor multicast zal operationeel moeten zijn uiterlijk 6 maanden na het besluit van het BIPT betreffende ten minste de kwalitatieve aspecten van het voorstel voor een referentieaanbod vanwege Belgacom. »<sup>4</sup>*

## 2.2.2 Synthese van de reacties

13. [Wordt later ingevuld]

## 2.3 DE RAADPLEGING VAN DE MEDIAREGULATOREN

### 2.3.1 Wettelijke basis

14. Na de nationale raadpleging zal een raadpleging van de mediaregulatoren plaatsvinden.
15. In artikel 3 van het samenwerkingsakkoord van 17 november 2006<sup>5</sup> wordt bepaald dat in bepaalde gevallen een ontwerpbeslissing dient te worden overgezonden naar de andere regulatoren:

*« Art. 3. Elke ontwerpbeslissing van een regulerende instantie die betrekking heeft op elektronische communicatienetwerken wordt door de desbetreffende instantie overgemaakt aan de andere regulerende instanties die zijn opgesomd in artikel 2, 2° van dit samenwerkingsakkoord.*

*De regulerende instanties die geconsulteerd worden bezorgen binnen de veertien kalenderdagen hun opmerkingen aan de regulerende instantie die de ontwerpbeslissing heeft overgemaakt. Binnen deze termijn kan elk van de regulerende instanties die geconsulteerd worden vragen dat de ontwerpbeslissing aanhangig wordt gemaakt bij de Conferentie van Regulatoren voor de elektronische Communicatiesector (hierna genoemd de CRC). Dit verzoek tot onmiddellijke overmaking aan de CRC wordt gemotiveerd.*

---

<sup>4</sup> Beslissing van de CRC van 1 juli 2011 met betrekking tot de analyse van de breedbandmarkten, r.o. 1109, 328.

<sup>5</sup> Samenwerkingsakkoord van 17 november 2006 tussen de federale staat, de Vlaamse Gemeenschap, de Franse Gemeenschap en de Duitstalige Gemeenschap betreffende het wederzijds raadplegen bij het opstellen van regelgeving inzake elektronische-communicatienetwerken, het uitwisselen van informatie en de uitoefening van de bevoegdheden met betrekking tot elektronische communicatienetwerken door regulerende instanties bevoegd voor telecommunicatie of radio-omroep, B.S. 28 december 2006, 75371.

*De betrokken regulerende instantie neemt de opmerkingen in aanmerking die de andere regulerende instanties eraan bezorgd hebben en maakt de gewijzigde ontwerpbeslissing over aan de andere regulerende instanties. Deze laatste beschikken na ontvangst van de gewijzigde ontwerpbeslissing over een termijn van 7 kalenderdagen waarbinnen zij kunnen vragen dat de gewijzigde ontwerpbeslissing aanhangig wordt gemaakt bij de CRC. »*

### 2.3.2 Resultaten van de raadpleging van de mediaregulatoren

16. [Wordt later ingevuld]

## 2.4 DE EUROPESE RAADPLEGING

### 2.4.1 Wettelijke basis

17. Artikel 7, § 3, van de Kaderrichtlijn<sup>6</sup> zoals gewijzigd door artikel 1, 6° van Richtlijn 2009/140/EG<sup>7</sup> bepaalt dat de Europese Commissie, BEREC en de nationale regelgevende instanties als volgt moeten worden geconsulteerd:

*« 3. Behalve wanneer anders bepaald in aanbevelingen of richtsnoeren die zijn vastgesteld op grond van artikel 7 ter, nadat de in artikel 6 bedoelde raadpleging is afgesloten, maakt een nationale regelgevende instantie, wanneer zij voornemens is een maatregel te nemen die:*

*a) valt binnen de draagwijdte van de artikelen 15 of 16 van deze richtlijn of de artikelen 5 of 8 van Richtlijn 2002/19/EG (toegangsrichtlijn); en*

*b) van invloed is op de handel tussen de lidstaten,*

*de ontwerpmaatregel tegelijkertijd toegankelijk is voor de Commissie, BEREC en de nationale regelgevende instanties in andere lidstaten, vergezeld van een motivering, overeenkomstig artikel 5, lid 3, en brengt zij de Commissie, BEREC en de andere nationale regelgevende instanties daarvan op de hoogte. De nationale regelgevende instanties, BEREC en de Commissie krijgen een maand de tijd om opmerkingen in te dienen bij de nationale regelgevende instantie in kwestie. De periode van één maand kan niet worden verlengd. »*

---

<sup>6</sup> Richtlijn 2002/21/EG van het Europees Parlement en de Raad van 7 maart 2002 inzake een gemeenschappelijk regelgevingskader voor elektronische-communicatienetwerken en -diensten, PB. L. 108, 24 april 2002, 41.

<sup>7</sup> Richtlijn 2009/140/EG van het Europees Parlement en de Raad van 25 november 2009 tot wijziging van Richtlijn 2002/21/EG inzake een gemeenschappelijk regelgevingskader voor elektronische-communicatienetwerken en -diensten, Richtlijn 2002/19/EG inzake de toegang tot en interconnectie van elektronische-communicatienetwerken en bijbehorende faciliteiten, en Richtlijn 2002/20/EG betreffende de machtiging voor elektronische-communicatienetwerken en -diensten, PB. L. 337, 18 december 2009, 48.

18. Artikel 141 van de wet van 13 juni 2005 betreffende de elektronische communicatie bepaalt dat de Europese Commissie als volgt moet worden geconsulteerd:

*« Art. 141. Voorzover een ontwerpbeslissing van het Instituut invloed kan hebben op de handel tussen de lidstaten en erop gericht is :*

*6° de wijziging van het referentieaanbod op te leggen, overeenkomstig artikel 59, § 4,*

*[...] raadpleegt het Instituut onverwijld de Europese Commissie en de nationale regelgevende instanties van de lidstaten.*

*Het Instituut neemt de opmerkingen in aanmerking die de Europese Commissie en de regelgevende instanties van de lidstaten eraan bezorgd hebben binnen de door de Koning bepaalde termijn. »*

19. Het huidige artikel 141 van de wet betreffende de elektronische communicatie maakt nog geen verwijzing naar de verplichte raadpleging van BEREC aangezien België Richtlijn 2009/140/EG nog niet omgezet heeft in nationale wetgeving. Gezien de omzettingstermijn van deze richtlijn<sup>8</sup> echter verstreken is en het BIPT van oordeel is dat het nieuwe artikel 7, 3° rechtstreekse werking heeft, zal ook BEREC geraadpleegd worden.

#### 2.4.2 Werkwijze en resultaten van de Europese raadpleging

20. [Wordt later ingevuld]

---

<sup>8</sup> Artikel 5 van Richtlijn 2009/140/EG stelt dat de lidstaten de bepalingen van die richtlijn uiterlijk op 25 mei 2011 omgezet moeten hebben.

### 3 REGLEMENTAIR KADER

#### 3.1 WETGEVING

21. De wet van 13 juni 2005 betreffende de elektronische communicatie<sup>9</sup> bepaalt dat de operatoren die op een markt over een sterke machtspositie<sup>10</sup> beschikken na afloop van de analyse van deze markt (onder andere) verplichtingen inzake toegang, non-discriminatie, kostenbasing en transparantie<sup>11</sup> opgelegd kunnen krijgen. De combinatie van de verplichting tot transparantie en non-discriminatie kan een regulator ertoe brengen om de SMP operator te verplichten een referentieaanbod voor te leggen<sup>12</sup>.
22. Het doel van de publicatie van een referentieaanbod is om duidelijkheid te bieden omtrent de voorwaarden die voldaan moeten worden om van de diensten van de operator met een sterke machtspositie te kunnen genieten en om voldoende op voorhand te kunnen beoordelen of deze voorwaarden wel redelijk zijn. Daarnaast moet het voldoende gespecificeerd zijn om te garanderen dat de operatoren niet hoeven te betalen voor faciliteiten die voor de gewenste dienst niet nodig zijn. Artikel 59 § 2 van de wet van 13 juni 2005 betreffende de elektronische communicatie stelt nog verder: “[In het referentieaanbod] *wordt een beschrijving gegeven van de betrokken aanbiedingen, uitgesplitst in diverse elementen naargelang van de marktbehoeften, en van de daaraan verbonden eisen en voorwaarden, met inbegrip van de tarieven*”.
23. Het referentieaanbod moet aan de realiteit beantwoorden en moet dus, indien nodig, geactualiseerd kunnen worden. Overeenkomstig artikel 59, § 4, van de wet van 13 juni 2005 betreffende de elektronische communicatie moet het BIPT het referentieaanbod te allen tijde kunnen wijzigen om rekening te houden met de ontwikkeling van de Belgacom-aanbiedingen en de verzoeken van de alternatieve operatoren. Belgacom is verplicht om de verzoeken van het BIPT om publicatie van bijkomende elementen, in te willigen. Bovendien bepaalt artikel 59, § 5, van de wet van 13 juni 2005: “*Elk referentieaanbod wordt, voordat het gepubliceerd wordt, door het Instituut goedgekeurd*”. Ook elke door Belgacom voorgestelde wijziging van het referentieaanbod moet door het BIPT goedgekeurd worden.
24. Daarnaast en voor zover nodig wil het BIPT nog het volgende benadrukken. Het feit dat sommige elementen van de referentieaanbieding waarop dit besluit betrekking heeft ongewijzigd zijn gebleven, betekent geenszins dat het BIPT zijn bevoegdheid verliest om ze later te wijzigen.<sup>13</sup>

---

<sup>9</sup> Hierna “WEC”.

<sup>10</sup> Hierna SMP operatoren.

<sup>11</sup> Art. 58-59 en 62 WEC.

<sup>12</sup> Art. 59 WEC.

<sup>13</sup> Brussel, 27 juni 2008, 2006/AR/468, consideransen 12 en 13; Brussel, 9 mei 2008, 2005/AR/1028; Brussel, 19 mei 2009, 2007/AR/302, considerans 114.

### 3.2 HET MARKTANALYSEBESLUIT VAN 1 JULI 2011

25. De beslissing van 1 juli 2011 betreffende de analyse van de breedbandmarkten is genomen door de Conferentie van Regulators voor de elektronische communicatiesector (CRC) op basis van artikel 3 van het samenwerkingsakkoord van 17 november 2006.<sup>14</sup>
26. Krachtens artikel 6 van het samenwerkingsakkoord van 17 november 2006<sup>15</sup> is het BIPT verantwoordelijk voor de uitvoering van de beslissing van de CRC van 1 juli 2011 betreffende de analyse van de breedbandmarkten.
27. De CRC heeft in haar beslissing van 1 juli 2011 besloten om een verplichting tot toegang betreffende de multicast-functie op te leggen:

*« Het BIPT verplicht Belgacom om elk redelijk verzoek om toegang tot een bitstreamproduct dat de multicastfunctionaliteiten omvat in te willigen (zie technische beschrijving in bijlage 3) gelijkwaardig aan deze die Belgacom intern of aan zijn dochterondernemingen of partners levert voor zijn retaildiensten.<sup>16</sup> »*

28. De beslissing van de CRC voorziet echter ook in de mogelijkheid voor Belgacom om een alternatief voorstel te doen voor multicast binnen de maand na de publicatie.

*« Binnen een maand na de publicatie van dit besluit mag Belgacom aan het BIPT de essentiële karakteristieken meedelen van een ander type wholesaledienst dat een alternatief voorstel zou vormen voor multicast (bijvoorbeeld toegang tot het IPTV-platform van Belgacom), voor zover dat alternatief de xDSL-operatoren in staat stelt om een retaildienst voor het uitzenden van video-inhoud in point-to-multipointformaat te verstrekken waarbij ze kunnen differentiëren in termen van inhoud (aan hun klanten bijkomende kanalen bieden naast diegene die Belgacom aan zijn eigen klanten levert alsook bepaalde kanalen uit het retailaanbod van Belgacom weglaten). Het BIPT zal zich over dit alternatief voorstel uitspreken.<sup>17</sup> »*

---

<sup>14</sup> Samenwerkingsakkoord van 17 november 2006 tussen de federale staat, de Vlaamse Gemeenschap, de Franse Gemeenschap en de Duitstalige Gemeenschap betreffende het wederzijds raadplegen bij het opstellen van regelgeving inzake elektronische-communicatienetwerken, het uitwisselen van informatie en de uitoefening van de bevoegdheden met betrekking tot elektronische communicatienetwerken door regulerende instanties bevoegd voor telecommunicatie of radio-omroep, B.S. 28 december 2006, 75371.

<sup>15</sup> « De regulerende instantie die de ontwerpbeslissing had voorgelegd, staat in voor de verdere uitvoering van de beslissing van de CRC. Deze regulerende instantie informeert de andere regulerende instanties die zijn opgesomd in artikel 2, 2°, van dit samenwerkingsakkoord over de maatregelen die genomen werden ter uitvoering van de beslissing van de CRC. »

<sup>16</sup> Beslissing van de CRC van 1 juli 2011 met betrekking tot de analyse van de breedbandmarkten, r.o. 1105, 325.

<sup>17</sup> Beslissing van de CRC van 1 juli 2011 met betrekking tot de analyse van de breedbandmarkten, r.o. 1109, 327.

29. De beslissing stelt dus dat indien Belgacom een alternatief voorstel zou indienen het BIPT dit voorstel zal moeten beoordelen. De uiteindelijk gemaakte keuze zal het onderwerp uitmaken van een nationale raadpleging waarna het BIPT de gekozen oplossing vastlegt in een besluit.

*« Het BIPT heeft het overigens bijzonder ter harte genomen om toe te zien op de evenredigheid van de remedie voor de SMP-operator en heeft deze laatste zo de mogelijkheid gelaten om alternatieven aan te reiken voor de remedie van toegang tot de multicastfunctionaliteiten. De uiteindelijk gekozen oplossing zal overigens worden onderworpen aan een nationale raadpleging en zal het voorwerp uitmaken van een besluit van het BIPT.<sup>18</sup> »*

30. De beslissing stelt verder dat indien het BIPT het alternatieve voorstel van Belgacom goedkeurt, Belgacom binnen twee maanden na de goedkeuring een concrete wijziging aan het referentieaanbod zal moeten voorleggen aan het BIPT. Het BIPT zal daarop de voorgestelde wijzigingen aan het referentieaanbod controleren en een of meerdere besluiten nemen aangaande de kwalitatieve en kwantitatieve aspecten hiervan. Belgacom beschikt over een periode van zes maanden vanaf het besluit van het BIPT betreffende ten minste de kwalitatieve aspecten van het voorstel van referentieaanbod om het referentieaanbod operationeel te maken.

31. Aangezien het BIPT het alternatieve voorstel van Belgacom goedgekeurd heeft<sup>19</sup>, moest Belgacom dus een referentieaanbod hiervoor voorstellen. Overeenkomstig hetgeen er bepaald is in de CRC-beslissing<sup>20</sup> betreffende de analyse van de breedbandmarkten aangaande het referentieaanbod voor toegang tot het binair debiet bevat een referentieaanbod minstens de volgende elementen<sup>21</sup> :

*Technische en tarifaire voorwaarden voor toegang tot binair debiet*

- netwerkbestanddelen waartoe toegang tot een binair debiet verleend wordt;
- informatie over de netwerkarchitectuur, de locaties van fysieke toegangssites en beschikbaarheid van de toegangsdiensten in de specifieke delen van het toegangsnetwerk;
- technische voorwaarden met betrekking tot de precieze kenmerken van de aansluitnetwerken en subaansluitnetwerken, de toegang tot de aansluitnetwerken en het gebruik ervan;

---

<sup>18</sup> Beslissing van de CRC van 1 juli 2011 met betrekking tot de analyse van de breedbandmarkten, r.o. 1131, 334.

<sup>19</sup> Paragraaf 50 van het [Besluit van de Raad van het BIPT van 4 januari 2012 betreffende de goedkeuring van het aanbod dat Belgacom als alternatief voorstelt voor de "multicast"-remedie](#), 21.

<sup>20</sup> Beslissing van de CRC van 1 juli 2011 met betrekking tot de analyse van de breedbandmarkten, r.o. 1156, 340.

<sup>21</sup> Beslissing van de CRC van 1 juli 2011 met betrekking tot de analyse van de breedbandmarkten, r.o. 1164, 342-344.

- procedures inzake bestelling en levering, beperkingen op het gebruik en, in voorkomend geval, contradictoire procedures inzake onderzoek en testen van de lijnen;
- er wordt voorzien in een SLA met boetes ingeval de SLA niet wordt nageleefd. Het referentieaanbod kan naar vrije keuze van de begunstigde voorzien in een redelijk voorspellingsstelsel als dat een toegevoegde waarde biedt voor de begunstigde. Geen enkel voorspellingsstelsel kan aan de begunstigde worden opgelegd. In dit laatste geval worden de processen uitgevoerd op "best effort" basis door de toegangsverlener.

#### Collocatiediensten

- informatie over de relevante sites van de operator met een sterke machtspositie, alsook de collocatiemogelijkheden op deze sites;
- kenmerken van de apparatuur : eventuele beperkingen op apparatuur die in collocatie kan worden geplaatst;
- maatregelen getroffen om de veiligheid van de lokalen te waarborgen;
- toegangsvoorwaarden voor het personeel van de concurrerende operatoren;
- veiligheidsnormen;
- regels voor de toekenning van ruimte wanneer de collocatieruimte beperkt is;
- regels voor de inspectie door de begunstigden van sites waar fysieke collocatie mogelijk is of deze waarvoor collocatie geweigerd werd.

#### Informaticasystemen

- voorwaarden inzake toegang tot operationele ondersteuningssystemen, informaticasystemen of databanken voor vooruitbestelling, bevoorrading, bestelling, facturering, alsook de procedures voor ontwikkeling van nieuwe functies, het onderhoud en de verzoeken om reparatie bij defecten en facturering van de operator met een sterke machtspositie.

#### Leveringsvoorwaarden

- termijn voor de inwilliging van verzoeken om levering van diensten en voorzieningen; overeenkomsten inzake het niveau van de dienstverlening, opheffing van storingen, escalatieprocedures en parameters voor de kwaliteit van de dienst;
- standaardcontractvoorwaarden, met, waar nodig, vergoeding voor de niet-nakoming van leveringstijden, alsook vergoeding voor het slecht controleren van de voorwaarden voor reparatie en levering;
- prijzen of prijsformules voor elk van de hierboven vermelde kenmerken, functies en voorzieningen.

#### Technische beperkingen

- Alleen de technische beperkingen, die uitdrukkelijk moeten worden gepreciseerd en die te wijten zijn aan de gebruikte apparatuur of aan de

betreffende versie ervan, mogen door Belgacom in aanmerking worden genomen. Die beperkingen mogen de technologische keuzemogelijkheden van de derde operatoren niet ten onrechte beperken. Elke andere configuratiemogelijkheid moet aan de keuze van de begunstigde worden overgelaten;

- Dat betekent dat het aanbod een technisch gedeelte moet bevatten dat de door Belgacom gebruikte apparatuur beschrijft, alsook de regels inzake engineering en de middelen om een sturing en diagnosestelling op afstand mogelijk te maken.

#### Migratie van de eindgebruikers

- migratiescenario van de DSL-eindgebruikers van Belgacom of van de DSL-eindgebruikers in het kader van DSL-doorverkoopaanbiedingen naar een dienst die wordt aangeboden in het kader van bitstreamtoegang;
- migratiescenario van toegang tot binair debiet naar ontbundeling;
- de voorwaarden inzake tarieven en technische aspecten van deze migratie.

32. Het BIPT zal via het huidige besluit het voorstel van referentieaanbod van Belgacom beoordelen. Dit besluit heeft betrekking op de kwalitatieve aspecten van het referentieaanbod.

## 4 ANALYSE VAN HET REFERENTIEAANBOD

33. De analyse van het BIPT zoals hieronder weergegeven wordt voorafgegaan door eventuele opmerkingen van de alternatieve operatoren en Belgacom die reeds door het BIPT in een eerste informele stadium zijn ontvangen. Deze reacties zijn in geen geval een vervanging van het officiële consultatieproces en vertegenwoordigen enkel het initiële standpunt van de partijen die aan de pre-consultatie hebben deelgenomen.

### 4.1 ONTBREKENDE ELEMENTEN

#### 4.1.1 Fast channel zapping & retransmission

##### Probleemstelling

34. De toevoeging van de functionaliteiten “fast channel zapping”<sup>22</sup> en “retransmission”<sup>23</sup> aan het referentieaanbod is volgens de alternatieve operatoren noodzakelijk om een beeldkwaliteit en een gebruikerservaring te bieden die gelijkwaardig is aan die van Belgacom.

35. Het hergebruik van deze Belgacom-functionaliteiten is volgens de alternatieve operatoren aangewezen omdat enkel Belgacom de schaalvoordelen heeft om meerdere servers dieper in het netwerk te installeren.

36. De OLO's kunnen door hun kleinere schaal slechts één server plaatsen, waardoor ze geen redundantie hebben zodat in het geval van netwerk- of server-problemen de zapsnelheid zal verlagen of de kans op beeldfouten zal toenemen. Daarnaast genereert één centrale server meer verkeer (en de hierbij samenhangende hogere kosten) over het transportnetwerk aangezien de server verder van de eindgebruiker staat.

##### Reactie Belgacom

37. In het aanbod is alles voorzien voor de alternatieve operator om deze diensten zelf te kunnen aanbieden :

37.1. De VQE<sup>24</sup>-server van de OLO, die via unicast de hertransmissie en het snelle zappen mogelijk maakt kan centraal bij de OLO geplaatst worden of via collocatie in elk interconnectiepunt (PoP<sup>25</sup>) van de 5 aggregatiezones ingeschakeld worden.

---

<sup>22</sup> Fast channel zapping: functionaliteit die tijdens het zappen reeds de beelden voor de volgende zender bij de server opvraagt om de zapsnelheid te verhogen.

<sup>23</sup> Retransmission: functionaliteit die corrupte data opnieuw naar de kijker verstuurt zodat de beeldkwaliteit niet geïmpacteerd wordt in het geval van transmissiefouten.

<sup>24</sup> VQE: Video Quality Experience. Deze VQE server verzorgt de retransmission en fast channel zapping functionaliteit.

<sup>25</sup> PoP: Point of Presence.

- 37.2. Deze VQE-server kan gebruikmaken van de door Belgacom gecapteerde beelden voor de zenders die zich in het gemeenschappelijk zenderaanbod van Belgacom bevinden. Deze beelden worden via de shared stream interface verzonden naar het platform (zie sectie 7.2 van annex 2: technical specifications) dat de alternatieve operator gebruikt om zijn specifieke kanalen te versturen naar het IPTV-platform van Belgacom. Op zijn beurt, moet de OLO deze beelden versturen naar zijn VQE-server(s) zodat de OLO dezelfde kijkerservaring kan aanbieden als Belgacom.
38. Er is wel een schaalverschil bij de installatie van een server in elke PoP, zoals Belgacom dat doet, maar dat kan opgevangen worden door de OLO door de VQE-server in slechts één punt in zijn core network te installeren en dan alle verkeer via de OLO Access Line (OAL)<sup>26</sup> van de OLO te versturen. Beide oplossingen zouden dezelfde gebruikerservaring bieden.
39. Eén gecentraliseerde server zal inderdaad extra trafiek genereren, maar daartegenover staat dat fast channel zapping niet zoveel verkeer veroorzaakt. Het is aan de OLO om te beslissen wat economisch gezien de meest aangewezen oplossing is: één server met een hogere transportkost of één server per aggregatiezone. Het BIPT kan deze economische analyse niet voor de geïnteresseerde operatoren doen maar houdt bij de bepaling ervan rekening met een geschatte kostprijs tussen 3251€ en 2828€ per VQE-server en dit volgens de Cisco Global Price List voor een CDE111-2 server.

#### Analyse BIPT

40. Het BIPT wil vooreerst benadrukken dat het doel van de opgelegde verplichting aangaande de multicastfunctionaliteiten is dat de alternatieve operatoren toegang zouden hebben tot een bitstreamproduct dat multicastfunctionaliteiten omvat die gelijkwaardig zijn aan deze die Belgacom intern aan zijn dochterondernemingen of partners levert voor zijn retaildiensten<sup>27</sup>.
41. Dit betekent echter niet dat de alternatieve operatoren in elk geval recht hebben op alle daaraan gelieerde functionaliteiten. De alternatieve operatoren hebben het recht om op een redelijke wijze de toegang te vragen tot deze bijkomende elementen waarbij geverifieerd zal moeten worden hoe belangrijk deze bijkomende elementen zijn voor het op gelijke basis kunnen concurreren met Belgacom. Daarnaast moet ook gekeken worden naar de mogelijkheid van de alternatieve operator om zelf op een efficiënte manier dergelijke functionaliteiten aan te bieden. Een dergelijke evaluatie kan zowel operationele als tarifaire aspecten omvatten.

---

<sup>26</sup> OAL: OLO access line: toegangslijn tussen interconnectiepunt Belgacom (PoP) en apparatuur van de alternatieve operator.

<sup>27</sup> Beslissing van de CRC van 1 juli 2011 met betrekking tot de analyse van de breedbandmarkten, r.o. 1105, 325.

42. Zoals zijn naam het zelf zegt zorgt een fast channel zapping server ervoor dat de klant sneller kan veranderen van kanaal, waarbij de zaptijd verandert van gemiddeld 2 seconden naar minder dan één seconde. Om een concurrentieel product te bekomen is het belangrijk dat de digitale ervaring qua gebruiksgemak de 1 seconde zapsnelheid van analoge televisie evenaart.
43. Hertransmissie heeft in de eerste plaats een impact op de robuustheid van het netwerk: het vermijdt namelijk dat een eindklant kortstondig een zwart scherm krijgt. De positieve impact van een hertransmissieserver is dus groot op overladen netwerken waar er veelvuldige fouten kunnen optreden en klein op een robuust netwerk waar er voldoende capaciteit ter beschikking staat. Sommige IPTV-netwerken maken vandaag de dag nog altijd geen gebruik van deze functionaliteiten.
44. Het is in elk geval belangrijk op te merken dat Belgacom alle mogelijkheden voorziet opdat de OLO's zelf fast channel zapping en retransmission kunnen implementeren.
45. In dit kader lijkt het voor het BIPT in eerste instantie niet noodzakelijk om Belgacom te verplichten deze functionaliteiten aan te bieden aan de OLO's. Het BIPT beseft echter dat de kosten om dergelijke functionaliteiten te implementeren een belangrijke rol kunnen spelen en in die zin wacht het de resultaten van de nationale raadpleging af om beter te kunnen oordelen over de proportionaliteit van de kosten verbonden aan een eigen implementatie. Het BIPT vraagt dan ook aan de geïnteresseerde operatoren om zich op duidelijke wijze uit te drukken tijdens de consultatieronde moesten zij niet akkoord zijn met de hiervoor bereikte conclusie, en dit zowel op het financiële als technische vlak.

#### 4.1.2 Hergebruik TV beelden voor diensten zoals catch-up, opname op afstand & multi-screen.

##### Probleemstelling

46. Belgacom biedt de tv-beelden van het gemeenschappelijk zenderaanbod aan voor fast channel zapping, maar de alternatieve operatoren vragen zich af of deze tv-beelden ook voor diensten zoals catch-up TV<sup>28</sup> (zoals Net Gemist, RTL à l'infini, ...), opname op afstand (in het netwerk) of de multi-screen toepassingen<sup>29</sup> gebruikt kunnen worden?

---

<sup>28</sup> Bekijken op aanvraag van onlangs uitgezonden programma's

<sup>29</sup> Bekijken van tv-beelden via verschillende schermen zoals tablets, smartphones, draagbare tv's en natuurlijk tv-toestellen

### Reactie Belgacom

47. Tv-beelden worden door Belgacom aangeboden voor unicast-diensten die een encryptering noodzakelijk maken zoals fast channel zapping en retransmission. Belgacom is van mening dat de OLO elke dienst die niet de bestaande encryptering ondersteunt, op basis van zijn eigen video head-end<sup>30</sup> zelf moet regelen of op commerciële basis aan Belgacom moet vragen aangezien het geen deel uitmaakt van het gereguleerd aanbod.
48. Belgacom heeft in §13 van de main body van het referentieaanbod aangegeven dat het niet tot het multicast aanbod behoort en §80 van de General Terms & Conditions stipuleert dat het gebruik van het multicastaanbod voor doeleinden die niet in overeenstemming zijn met de technische specificaties in annex 2 een reden kunnen zijn tot schorsing/beëindiging van het contract.

### Analyse BIPT

49. Het BIPT wil bij deze zijn stelling bij het punt betreffende toegang tot fast channel zapping- en retransmission-servers herhalen namelijk dat het doel van de opgelegde verplichting aangaande de multicastfunctionaliteiten is dat de alternatieve operatoren toegang zouden hebben tot een bitstreamproduct dat multicastfunctionaliteiten omvat die gelijkwaardig zijn aan deze die Belgacom intern aan zijn dochterondernemingen of partners levert voor zijn retaildiensten<sup>31</sup>.
50. Dit betekent echter niet dat de alternatieve operatoren in elk geval recht hebben op alle daaraan gelieerde functionaliteiten. De alternatieve operatoren hebben het recht om op een redelijke wijze de toegang te vragen tot deze bijkomende elementen waarbij geverifieerd zal moeten worden hoe belangrijk deze bijkomende elementen zijn voor het op gelijke basis kunnen concurreren met Belgacom. Daarnaast moet ook gekeken worden naar de mogelijkheid van de alternatieve operator om zelf op een efficiënte manier dergelijke functionaliteiten aan te bieden. Een dergelijke evaluatie kan zowel operationele als tarifaire aspecten omvatten.
51. Hieronder wordt voor elke van deze diensten de situatie geanalyseerd.

---

<sup>30</sup> Video head-end : apparatuur die de beelden van verschillende zenders capteert en naar de televisiekijkers verstuurt.

<sup>31</sup> Beslissing van de CRC van 1 juli 2011 met betrekking tot de analyse van de breedbandmarkten, r.o. 1105, 325.

52. Wat het hergebruik van de TV beelden voor een opname in het netwerk (nPVR<sup>32</sup>) betreft heeft Belgacom erkend dat het technisch mogelijk is. Belgacom heeft een aantal servers geïnstalleerd waarop voor de meest bekeken zenders al het beeldmateriaal 24u/24 opgeslagen wordt gedurende één maand. Indien de kijker thuis op voorhand heeft aangegeven dat hij een bepaald programma wil opslaan in het netwerk, dan kan die dat tot 30 dagen na uitzending herbekijken door contact te leggen met deze servers en het beeldmateriaal wordt dan vanaf een bepaald beginuur naar zijn decoder doorgestuurd.
53. De alternatieve operatoren kunnen zelf deze functionaliteit ontwikkelen en vragen om enkel de door Belgacom aangeleverde beelden te hergebruiken. Dit is geen probleem voor de alternatieve operatoren want zij beschikken reeds over de sleutels om deze beelden voor dergelijke doeleinden te hergebruiken. Dit levert bovendien geen bijkomende kosten op voor Belgacom. Indien de OLO's deze beelden niet mogen hergebruiken dan moeten ze deze gemeenschappelijke zenders alsnog zelf capteren en worden er extra kosten gegenereerd. Om te capteren zijn er immers twee mogelijkheden: ofwel (1) mag de OLO een dataverbinding leggen naar de server van de zender zodat deze zijn beelden kan doorsturen (indien de zender daartoe bereid is) ofwel (2) moet de OLO zelf een server installeren bij elke zender om de beelden continu op te nemen zodat hij de beelden zelf naar zijn netwerk kan versturen wanneer de eindgebruiker een opname in het netwerk opvraagt. De kosten voor een dergelijke installatie zijn niet te onderschatten waardoor het efficiënter lijkt om dezelfde beelden te gebruiken en zo de schaalvoordelen van Belgacom (waar de OLOs niet over beschikken) uit te spelen.
54. De functionaliteit "opname in het netwerk" is bovendien belangrijk voor de gebruikerservaring aangezien het aantal programma's dat tegelijk kan bekeken of opgenomen worden, beperkt wordt door de capaciteit van de breedbandtoegang. Een eindgebruiker verwacht dat hij op verschillende televisieschermen in het huis TV kan kijken en tegelijk programma's kan opnemen en dat hij daarnaast ook programma's kan herbekijken die onlangs uitgezonden werden. Door "opname in het netwerk" wordt de beschikbare capaciteit van het aansluitnetwerk optimaal gebruikt voor het consumeren van tv-beelden en kan er dus vermeden worden dat een groot deel van de beschikbare capaciteit ingenomen wordt door de vraag voor opnames. In dit opzicht vraagt het BIPT dan ook aan alle geïnteresseerde operatoren om zich op duidelijke wijze uit te drukken tijdens de consultatieronde, en dit zowel op het financiële als technische vlak.
55. Wat het hergebruik van de tv-beelden voor het herbekijken van onlangs uitgezonden programma's betreft, moet allereerst opgemerkt worden dat deze content op twee manieren kan aangeboden worden:

55.1. ofwel door de zender zelf via videobestanden

---

<sup>32</sup> nPVR: network Personal Video Recorder.

- 55.2. ofwel door de operator die deze videobestanden zelf heeft moeten creëren door de lineaire tv-beelden te knippen en te verpakken in videobestanden die opgevraagd kunnen worden.
56. Belgacom is van mening dat een OLO dit zelf kan doen. Het BIPT vraagt zich echter af wat de kosten zijn die een alternatieve operator moet maken om een dergelijke functionaliteit aan te bieden en of een efficiënte operator deze dienst niet zou kunnen aanbieden via het referentieaanbod om zo grotere schaalvoordelen en lagere kosten voor zijn eigen platform te bekomen. In dit opzicht vraagt het BIPT dan ook aan alle geïnteresseerde operatoren om zich op duidelijke wijze uit te drukken tijdens de consultatieronde, en dit zowel op het financiële als technische vlak.
57. Wat het hergebruiken van de TV beelden via verschillende schermen zoals tablets, smartphones en computerschermen betreft (bijvoorbeeld TV Overall/TV Partout van Belgacom), wordt het door Belgacom niet toegelaten omdat er een hercodering<sup>33</sup> noodzakelijk is. De OLO's beschikken bovendien over alle mogelijkheden om zelf deze functionaliteiten te implementeren. Het voorbeeld van Alpha Networks dat dergelijke TV diensten ook aanbiedt via het internet in zijn Billi aanbod, geeft aan dat het mogelijk is voor een alternatieve operator om dergelijke diensten zelf te ontwikkelen.

#### 4.1.3 Dekking & beschikbaarheid van aantal SD/HD streams

##### Probleemstelling

58. De informatie ontbreekt over de dekking en beschikbaarheid van het aantal SD & HD streams voor de verschillende toegangszones. De OLOs willen :
- 58.1. bevestiging dat het aanbod geldt voor het volledige VDSL 2-netwerk;
- 58.2. informatie over het potentieel voor SD/HD en het aantal streams dat aan een klant aangeboden kan worden. Deze info voor het volledige netwerk is nodig om een ondernemingsplan op te kunnen stellen (bijv. in de stratendatabase NSD34);
- 58.3. dat de inquiry tool aangeeft of HD mogelijk is voor de gevraagde aansluiting.

##### Reactie van Belgacom

59. Dit multicast-referentieaanbod is beschikbaar voor alle WBA VDSL2-toegangslijnen.

---

<sup>33</sup> Deze dienst kan alleen aangeboden worden indien de dienstverlener beschikt over de pure beeldenstroom van de verschillende zenders waarna deze beelden worden geëncodeerd en geëncrypteerd per scherm.

<sup>34</sup> NSD: National Street Database

60. De alternatieve operator kan nu reeds op basis van de LLU Inquiry tool het mogelijke lijnprofiel per toegangslijn bekijken. Daarnaast komt er op de beveiligde website een overzicht van de bandwidth-capaciteit die elk kanaal vereist. Op basis van deze twee documenten kan de alternatieve operator bepalen of de eindgebruiker HD-kanalen kan aangeboden worden en hoeveel verschillende zenders tegelijk naar de eindgebruiker gestuurd kunnen worden.

#### Analyse BIPT

61. De informatie aangaande de dekking en beschikbaarheid van het aantal SD/HD-streams is belangrijk voor de alternatieve operatoren om op een geïnformeerde wijze een accuraat businessplan op te kunnen stellen. Zonder deze informatie is het voor de alternatieve operatoren niet mogelijk om de verschillende mogelijke strategische keuzes tegen elkaar af te wegen. Door deze verschillende informatie op één centrale plaats te bundelen, wordt het tevens gemakkelijker de consument voldoende te informeren bij zijn bestelling en wordt de kans op menselijke fouten bij het ingeven van de bestelling verkleint.

62. Het BIPT vraagt dat Belgacom de gevraagde informatie meedeelt aan de OLO's zodat er een maximale transparantie kan bestaan over de concrete draagwijdte van het referentieaanbod en zijn diverse elementen. Het referentieaanbod moet de alternatieve operatoren namelijk in staat stellen om alleen de verrichtingen aan te kopen die ze nodig hebben<sup>35</sup>. In die zin moet zij dus overzichtelijk en transparant zijn. Het kan niet de bedoeling zijn dat een OLO eerst een puzzelwerk met betrekking tot het verzamelen van informatie moet starten vooraleer het duidelijk wordt welke diensten er in het referentieaanbod aangeboden worden.

## **4.2 TRANSPARANTIE OVER DE EVOLUTIE VAN HET AANBOD**

### **4.2.1 Toevoegen van een zender aan het gemeenschappelijk zenderaanbod**

#### Probleemstelling

63. Er bestaat onduidelijkheid of Belgacom in de toekomst nog gemeenschappelijke zenders aan het aanbod zal toevoegen. Daarnaast bestaat er onduidelijkheid over welk proces zal gevolgd worden alsook de toepassing van een notificatieperiode voor de alternatieve operatoren.

#### Reactie van Belgacom

64. Belgacom kan enkel een nieuwe zender toevoegen aan het gemeenschappelijk zenderaanbod door een gemeenschappelijke zender te schrappen en te vervangen door een andere zender. Wanneer in de toekomst de netwerkcapaciteit uitgebreid wordt en er bijkomende capaciteit beschikbaar is, kan er wel een kanaal toegevoegd worden zonder dat er een andere zender verwijderd wordt.

---

<sup>35</sup> Beslissing van de CRC van 1 juli 2011 met betrekking tot de analyse van de breedbandmarkten, r.o. 1158, 340.

65. Daarenboven staat er in het referentieaanbodaanbod dat Belgacom verantwoordelijk is voor het schrappen of toevoegen van zenders in de common pool, waarbij het aanbod van de beschikbare zenders niet nader wordt omschreven.

#### Analyse BIPT

66. Het BIPT benadrukt vooreest dat krachtens de non-discriminatieverplichting Belgacom pas voor zichzelf een nieuwe configuratie van de breedbandaanbiedingen (nieuwe parameters, nieuwe functies, nieuwe netwerkelementen, nieuwe technologie, ...) zal mogen gebruiken wanneer deze configuratie operationeel is op wholesaleniveau<sup>36</sup>. Deze verplichting is eveneens van toepassing op het alternatief dat Belgacom heeft voorgesteld ten aanzien van de multicastfunctie<sup>37</sup>.
67. Een redelijke notificatieperiode voor het toevoegen van een zender aan het gemeenschappelijk zenderaanbod is noodzakelijk om de alternatieve operatoren de tijd te geven hun operationele ondersteuningssystemen en IT-systemen te wijzigen, om de nodige contentrechten te kunnen bekomen en hun klanten hiervan tijdig en in elk geval op hetzelfde moment als Belgacom op de hoogte te kunnen brengen. Het BIPT is van mening dat een periode van twee maanden voldoende is hiervoor.
68. Belgacom moet in het aanbod verduidelijken dat er een notificatieperiode van twee maanden bestaat voor wat betreft het toevoegen van zenders aan zijn gemeenschappelijk zenderaanbod. Deze termijn is noodzakelijk opdat de OLO's over voldoende tijd beschikken en zodoende op eenzelfde ogenblik als Belgacom de dienst kunnen lanceren.

#### **4.2.2 Verwijderen van een zender uit het gemeenschappelijk zenderaanbod**

##### Probleemstelling

69. Belgacom voorziet een notificatieperiode van 2 maanden voor de alternatieve operatoren bij het schrappen van een zender uit het gemeenschappelijk zenderaanbod om een eindgebruiker te verwittigen.
70. De alternatieve operatoren vragen zich tevens af of het mogelijk is om op twee maanden tijd een zender uit het gemeenschappelijk zenderaanbod te migreren naar hun beschikbare reservecapaciteit gezien er slechts tweemaal per jaar een aanpassing mogelijk is aan deze beschikbare reservecapaciteit.

---

<sup>36</sup> Beslissing van de CRC van 1 juli 2011 met betrekking tot de analyse van de breedbandmarkten, r.o. 1253, 352-353.

<sup>37</sup> Beslissing van de CRC van 1 juli 2011 met betrekking tot de analyse van de breedbandmarkten, r.o. 1156, 340.

### Reactie van Belgacom

71. De retailcontracten van Belgacom bevatten geen verplichtingen voor wat betreft de aangeboden zenders. Belgacom kan daardoor zenders toevoegen en verwijderen zonder de verplichting tot notificatie van de eindklant. Bijgevolg beschouwt Belgacom het schrappen en/of toevoegen van zenders niet als een verandering van het contract waardoor de wet betreffende de marktpraktijken volgens Belgacom niet geschonden wordt.
72. Wat het beheren van de beschikbare reservecapaciteit betreft, kan de alternatieve operator tweemaal per jaar zijn instellingen aanpassen. In het beheer van zijn beschikbare reservecapaciteit kan een voorzienende operator reeds ruimte voorzien voor toekomstige zenders, die de komende 6 maanden kunnen toegevoegd worden als gevolg van eigen contentonderhandelingen of door het schrappen van een zender uit de common pool. Belgacom merkt tevens op dat het amper twee zenders per jaar schrapt.
73. De migratie van een zender uit het gemeenschappelijk zenderaanbod naar de beschikbare reservecapaciteit kost 5 weken implementatietijd bij Belgacom, dus de OLO heeft na de notificatie nog 3 weken speling om te beslissen of hij ook de zender stopzet of deze zender verplaatst naar zijn beschikbare reservecapaciteit met eigen captatie van de beelden.

### Analyse BIPT

74. Het BIPT benadrukt vooreerst dat krachtens de non-discrimatieverplichting Belgacom pas voor zichzelf een nieuwe configuratie van de breedbandaanbiedingen (nieuwe parameters, nieuwe functies, nieuwe netwerkelementen, nieuwe technologie, ...) mag gebruiken wanneer deze configuratie operationeel is op wholesaleniveau<sup>38</sup>. Deze verplichting is eveneens van toepassing op het alternatief dat Belgacom heeft voorgesteld ten aanzien van de multicastfunctie<sup>39</sup>.
75. Wanneer een kanaal geschrapt wordt uit het gemeenschappelijk zenderaanbod verdwijnt deze zender in principe ook voor de alternatieve operator. Dit heeft mogelijk een zware impact op de eindgebruikerservaring en kan het businessplan van een alternatieve operator ernstig verstoren. Het dus logisch dat de alternatieve operatoren tijdig ingelicht moeten worden van dergelijke wijzigingen zodat zij zich hier adequaat op kunnen voorbereiden. Om een goede klantrelatie te kunnen onderhouden, is het bovendien ook noodzakelijk om de verwijdering van een kanaal op tijd te melden. In eerste instantie gaat het BIPT na of er geen discriminatie plaatsvindt tussen de behandeling van de OLO en Belgacom retail, maar in tweede instantie verifieert het BIPT eveneens of de verplichtingen ten aanzien van de eindgebruiker nageleefd worden.

---

<sup>38</sup> Beslissing van de CRC van 1 juli 2011 met betrekking tot de analyse van de breedbandmarkten, r.o. 1205, 352-353.

<sup>39</sup> Beslissing van de CRC van 1 juli 2011 met betrekking tot de analyse van de breedbandmarkten, r.o. 1156, 340.

76. Het schrappen uit de gemeenschappelijke zenderlijst betekent niet noodzakelijk dat de alternatieve operator deze zender niet meer kan uitzenden. Het aanbieden van deze zender zal vanaf dan echter moeten gebeuren via een toegewijd kanaal. Om deze operatie soepel en efficiënt te kunnen laten verlopen is het tevens noodzakelijk dat de OLO over voldoende tijd beschikt.
77. In het kader van de raadpleging vraagt het BIPT wat de visie van de sector is op de argumenten die Belgacom aanhaalt om een notificatieperiode van 2 maanden te rechtvaardigen. Indien de alternatieve operatoren een langere notificatieperiode noodzakelijk achten, vraagt het BIPT aan deze operatoren om elementen aan te brengen die dit rechtvaardigen.
78. Het BIPT spreekt zich in het kader van deze dit besluit niet uit over de toepassing van de Wet van 6 april 2010 betreffende marktpraktijken daar het niet bevoegd is voor de controle van de naleving deze wet.

#### 4.2.3 Beschikbare capaciteit voor toegewijde zenders

##### Probleemstelling

79. De alternatieve operatoren vragen transparantie over hoe de beschikbare capaciteit voor toegewijde zenders de komende jaren zal evolueren. Er moet voldoende capaciteit voor bijkomende zenders beschikbaar blijven zodat alternatieve operatoren hun zenderaanbod kunnen differentiëren.
80. De beslissing van de CRC van 1 juli 2011 met betrekking tot de analyse van de breedbandmarkten stelt immers dat Belgacom een alternatief voor de multicastfunctie mag voorstellen, en stelt daarbij expliciet : *[...] voor zover dat alternatief de xDSL-operatoren in staat stelt om een retaildienst voor het uitzenden van video-inhoud in point-to-multipointformaat te verstrekken waarbij ze kunnen differentiëren in termen van inhoud (aan hun klanten bijkomende kanalen bieden naast diegene die Belgacom aan zijn eigen levert alsook bepaalde kanalen uit het retailaanbod van Belgacom weglaten).*<sup>40</sup>

##### Reactie van Belgacom

81. De overblijvende transportcapaciteit wordt momenteel onder 4 partijen (Belgacom + 3 OLO's) verdeeld. Elke partij krijgt 25 Mbps capaciteit voor toegewijde zenders.

---

<sup>40</sup> Beslissing van de CRC van 1 juli 2011 met betrekking tot de analyse van de breedbandmarkten, r.o. 1109, 326.

82. Na één jaar is er een evaluatie van de capaciteit voorzien<sup>41</sup> op basis van de evolutie van het netwerk en het aantal afnemers van deze beschikbare reservecapaciteit. Eventueel kunnen bestaande klanten na deze evaluatie bijkomende capaciteit aanvragen indien er nog capaciteit beschikbaar is.
83. Een herziening van de beschikbare capaciteit op langere termijn is mogelijk nadat er in meer transportcapaciteit werd geïnvesteerd.

#### Analyse BIPT

84. Het BIPT vraagt omwille van transparantie aan Belgacom om duidelijk op te nemen in het referentieaanbod (hoofdstuk 4.5 van de Main Body) dat de beschikbare capaciteit gaat geëvalueerd worden na één jaar. Om te zorgen voor een eerlijke concurrentie en investeringen te stimuleren is het belangrijk dat er voorafgaand aan de toekomstige netwerkevoluties voldoende transparantie is over deze evoluties. Die transparantie is nodig voor de alternatieve operator opdat hij zijn commerciële model en zijn activiteiten zou kunnen aanpassen aan het toekomstige netwerk en de nieuwe producten<sup>42</sup>.
85. Een mogelijke aanpassing van de toekenningsregels voor de beschikbare reservecapaciteit moeten aan het BIPT voorgelegd worden ter goedkeuring.

#### **4.2.4 Aanpassingen die een impact hebben op de firmware van de decoders**

##### Probleemstelling

86. Er is meer visibiliteit betreffende de technologische evoluties nodig. Codec aanpassingen hebben een grote impact op de firmware decoder die door de OLO moet aangepast en voldoende getest worden. Daarom moeten deze aanpassingen meer dan de voorziene 3 maanden (Annex 2: technical specifications, §40) op voorhand gecommuniceerd worden.

##### Reactie van Belgacom

87. Belgacom heeft een verduidelijking toegevoegd omtrent de aanpassingen aan gedeelde zenders (Hoofdstuk 13 van de Annex 3 - P&O). Hierbij wordt er afhankelijk van de grootte van de impact van de aanpassing een aangepaste notificatietermijn voorzien om dergelijke aanpassingen in goede banen te leiden. Een project manager zal aangewezen worden die statusrapporten verstrekt aan de alternatieve operatoren.
88. Belgacom heeft tijdens de vergadering van 12 april 2012 aan het BIPT gemeld dat dit nieuwe proces werkt met een projectgebaseerde timing en verschillende milestones die samen met de OLO's uitgewerkt worden:

---

<sup>41</sup> Besluit van het BIPT van 4 januari 2012 betreffende de goedkeuring van het aanbod dat Belgacom als alternatief voorstelt voor de "multicast"-remedie opgelegd door het beslissing van de CRC van 1 juli 2011 betreffende de analyse van de breedbandmarkten, r.o. 39, 18.

<sup>42</sup> Beslissing van de CRC van 1 juli 2011 met betrekking tot de analyse van de breedbandmarkten, r.o. 1197, 351.

- Milestone t1: overzicht van aanpassingen aan specificaties & high level planning. In deze fase controleren Belgacom en de OLO's de impact op de software van het tv-platform en de decoder.
- Milestone t2: akkoord tussen Belgacom en de OLO's over de finale planning waarna er wordt overgegaan tot een aantal testen in het labo van de OLO. Belgacom verstrekt een of meerdere samples van de aangepaste stream om de OLO's in staat te stellen hun eigen labotesten te doen.
- Milestone t3 live testing: Belgacom verstrekt een aangepaste stream op het Belgacom TV-platform (met multicast-adres) om testen te kunnen uitvoeren bij de reële eindgebruiker.
- Milestone t4: het definitieve groene licht wordt gegeven voor het doorvoeren van de aanpassing (via een wijziging aan het referentieaanbod) nadat alle operatoren hun fiat hebben gegeven.
- Milestone t5 Live Release : de aanpassing wordt doorgevoerd voor alle operatoren, Belgacom inclusief.

89. Dit proces loopt parallel aan het interne testing-proces bij Belgacom waardoor er geen discriminatie kan optreden tussen Belgacom en de OLO's.

90. Belgacom heeft toegezegd een roadmap met de geplande evoluties te verstrekken. In 2013 is er één upgrade van de decodersoftware voorzien.

#### Analyse BIPT

91. Het BIPT benadrukt vooreerst dat krachtens de non-discriminatieverplichting Belgacom pas voor zichzelf een nieuwe configuratie van de breedbandaanbiedingen (nieuwe parameters, nieuwe functies, nieuwe netwerkelementen, nieuwe technologie, ...) zal mogen gebruiken wanneer deze configuratie operationeel is op wholesaleniveau<sup>43</sup>. Deze verplichting is eveneens van toepassing op het alternatief dat Belgacom heeft voorgesteld ten aanzien van de multicastfunctie<sup>44</sup>.

92. Het BIPT vraagt in het kader van deze nationale raadpleging, wat de mening is van de alternatieve operatoren over deze door Belgacom voorgestelde procedure. Laat de voorgestelde werkwijze de alternatieve operator toe om tijdig de nodige aanpassingen te maken zodat zijn eigen dienstverlening niet in het gedrang komt?

93. Het BIPT vraagt aan Belgacom om milestone 4, die een wijziging aan het referentieaanbod zou betreffen, ter goedkeuring aan het BIPT voor te leggen, zodat het BIPT kan nagaan of alle operatoren op tijd kunnen klaar geraken om deze aanpassingen te implementeren.

---

<sup>43</sup> Beslissing van de CRC van 1 juli 2011 met betrekking tot de analyse van de breedbandmarkten, r.o. 1205, 352-353.

<sup>44</sup> Beslissing van de CRC van 1 juli 2011 met betrekking tot de analyse van de breedbandmarkten, r.o. 1156, 340.

94. Een controle van het BIPT is noodzakelijk aangezien de dienstverlening van een alternatieve operator aan zijn consumenten in het gedrang kan komen, wanneer die niet voldoende tijd heeft om zijn apparatuur aan te passen. Dit zou de concurrentie zware schade toe brengen en de consument problemen opleveren.
95. Ten slotte vraagt het BIPT aan Belgacom omwille van transparantie om jaarlijks een roadmap met de geplande evoluties van de decodersoftware te verstrekken, zodat de alternatieve operatoren deze impact kunnen incalculeren in hun eigen IT roadmap en voldoende resources kunnen uittrekken om dergelijke aanpassingen snel te kunnen uitvoeren. Het BIPT stelt voor om dit op te nemen in de reeds bestaande jaarlijkse communicatie over de evolutie van het Belgacom-netwerk.

#### 4.2.5 Sluiting van de centrales

##### Probleemstelling

96. Er bestaat onduidelijkheid over de gevolgen van de sluiting van een aantal centrales in het kader van de netwerkontwikkelingen van Belgacom en de weerslag die dit zal hebben op dit aanbod van Belgacom. In die zin vragen de OLO's wat de operationele impact is van de sluiting van de centrales op dit multicast-referentieaanbod.

##### Reactie van Belgacom

97. De sluiting van de centrales heeft geen impact op het multicast-gedeelte zolang de WBA-toegang beschikbaar blijft voor de klant, want de multicastfunctionaliteit wordt automatisch toegevoegd aan de WBA-toegang. In de centrale zelf worden geen elementen met betrekking tot het tv-platform geïnstalleerd.
98. Indien de WBA-toegang moet gemigreerd worden, wordt dit geregeld via het WBA VDSL2-referentieaanbod, maar is er geen specifieke impact op het multicast-gedeelte.

##### Analyse BIPT

99. Het BIPT erkent dat een grote mate van transparantie essentieel is voor het goed verlopen van dit zwaar impacterend project. In die zin vraagt het BIPT dat Belgacom zo transparant mogelijk communiceert naar de betrokken partijen, overeenkomstig §1192 e.v. van de CRC-beslissing van 1 juli 2011 betreffende de analyse van de breedbandmarkten.

*“In het kader van de overgang naar NGA/NGN, zoals toegelicht in deel 6.2.2, zal Belgacom aan het BIPT en aan de alternatieve operatoren zijn netwerkontwikkelingsprojecten per streek over een periode van vijf jaar meedelen. De meegedeelde informatie omvat onder andere:*

- *alle geplande aanpassingen op de bestaande wholesaletaegangspunten;*
- *alle geplande sluitingen van punten waar wholesaletaegang wordt geleverd;*
- *het tijdschema van de verwachte/geplande netwerktransformaties.”*

## 4.3 DE IMPLEMENTATIE VAN HET AANBOD

### 4.3.1 Timing

#### Probleemstelling

100. De alternatieve operatoren vragen om de implementatieplanning van de multicast-referentieaanbieding te verduidelijken.

#### Reactie van Belgacom

101. De release van 13 maart 2013 zal de essentiële elementen bevatten voor provisioning, repair & monitoring. Belgacom verwacht dat er na deze release nog 3 bijkomende weken noodzakelijk zullen zijn om alle bugs uit de software te verwijderen.

102. Vervolgens kan een friendly user test van start gaan die ten minste één maand zal duren. Hierbij is het essentieel dat de interface voor bestellingen en de uitwisseling van de CAS-sleutels voldoende getest wordt.

103. Belgacom zal tevens een document “Roles & Responsibilities” verstrekken voor de decoders van het platform.

#### Analyse BIPT

104. Het BIPT herhaalt hier ter verduidelijking dat Belgacom de timing van de implementatie zoals voorzien door het marktanalysebesluit moet respecteren:

*“Het referentieaanbod in verband met het voormelde alternatief voor multicast zal operationeel moeten zijn uiterlijk 6 maanden na het besluit van het BIPT betreffende ten minste de kwalitatieve aspecten van het voorstel voor een referentieaanbod vanwege Belgacom.”<sup>45</sup>*

105. De implementatie van de multicastfunctionaliteiten dient efficiënt en doelmatig te zijn teneinde van nut te zijn voor de ontwikkeling van een gezonde concurrentie op de breedbandmarkt.

106. Het is daarnaast ook belangrijk dat er voldoende transparantie bestaat tussen Belgacom en de alternatieve operatoren tijdens de implementatieperiode zelf. Het is essentieel voor de ondersteunende diensten van de alternatieve operatoren om op tijd op de hoogte te zijn van de volgende stappen opdat zij zich tijdig en adequaat kunnen voorbereiden op elke nieuwe stap.

107. Het BIPT vraagt in het kader van de nationale raadpleging een reactie van de alternatieve operatoren op de haalbaarheid van de voorgestelde timing van Belgacom.

---

<sup>45</sup> Beslissing van de CRC van 1 juli 2011 met betrekking tot de analyse van de breedbandmarkten, r.o. 1109, 326-327.

108. Daarnaast vraagt het BIPT in het kader van deze raadpleging eveneens de timing van de alternatieve operatoren voor de implementatie van hun eigen IT-systemen.

#### 4.3.2 Activatie van multicast-aanbod & XML Description

##### Probleemstelling

109. Er heerst onduidelijkheid over de bestelprocedure bij de OLO's want zij weten niet of internet en tv samen kunnen besteld worden voor een nieuwe klant mits één enkel XML-formulier. Het is onduidelijk hoe een bestaande WBA VDSL2-klant zonder tv zijn product kan veranderen naar een WBA-product met tv. Er moet meer transparantie gegeven worden over de procedures en processen die Belgacom hiervoor ter beschikking zal stellen.

110. In geval dat er een aanpassing komt aan de XML description voor tv (wat ook een impact heeft op WBA), dan moet dit minstens 6 maanden voor de lancering beschikbaar zijn.

##### Reactie van Belgacom

111. Voor tv moet enkel een bijkomende P3<sup>46</sup> VLAN besteld worden. Deze kan besteld worden samen met de bestelling van een WBA-lijn of afzonderlijk, in het geval van een al bestaande WBA-lijn. Belgacom heeft de activatieprocedure verduidelijkt in een nieuwe versie van het referentieaanbod (hoofdstuk 9 van Annex 3 - P&O) op 7 mei 2012.

112. Het gaat over een minimale IT-aanpassing aangezien de XML-structuren voor het bestellen van een VLAN met prioriteit P3 hergebruikt worden:

112.1. Kleine aanpassing via "change" message in WBA VDSL2-aanbod indien multicast toegevoegd wordt aan een bestaande WBA-lijn;

112.2. Of via "provide new" voor nieuwe WBA VDSL2-lijn om breedbandtoegang en multicast samen te bestellen.

113. De timing voor de XML description zal nog door Belgacom verstrekt worden.

##### Analyse BIPT

114. De toegang tot de multicastfunctionaliteiten dient efficiënt en doelmatig te zijn teneinde van nut te zijn voor de ontwikkeling van een gezonde concurrentie op de breedbandmarkt. De levering van dat type van dienst moet ook de essentiële principes van transparantie en non-discriminatie in acht nemen. In dat opzicht vindt het BIPT de uitleg van Belgacom toereikend want multicast is een toegevoegde dienst aan het WBA VDSL2-aanbod via een nieuw VLAN en stelt als dusdanig niet meer voor dan een "vakje aankruisen" bij de bestelling van een WBA VDSL2-lijn.

---

<sup>46</sup> Prioriteit P3 is nodig om een voldoende goede beeldkwaliteit te leveren.

115. Het BIPT vraagt in het kader van de raadpleging of er nog aspecten omtrent de activatieprocedure onduidelijk zijn voor de sector na de door Belgacom aangebrachte verduidelijkingen.

116. Daarnaast vraagt het BIPT aan Belgacom in het kader van deze nationale raadpleging aan Belgacom om de XML content description minstens 6 maanden voor de lancering ter beschikking te stellen zodat de OLO zijn IT-systemen tijdig kan ontwikkelen en zodat hij, van zodra Belgacom dit multicast-referentieaanbod lanceert, kan starten.

#### 4.3.3 Documenten op de beveiligde website

##### Probleemstelling

117. De alternatieve operatoren vragen wanneer de documenten op de beveiligde website waarnaar verwezen wordt in het referentieaanbod beschikbaar zullen zijn.

##### Reactie van Belgacom

118. Belgacom gaat de documenten ophalen die op de beveiligde website zullen komen en voor elk van deze documenten een timing verstrekken.

##### Analyse BIPT

119. Het BIPT vraagt aan Belgacom om deze lijst met een indicatieve timing tegen 10 juni 2012 aan het BIPT over te maken. Het referentieaanbod moet de alternatieve operatoren in staat stellen om alleen de verrichtingen aan te kopen die ze nodig hebben. Het referentieaanbod moet voldoende gedetailleerd zijn zodat diegene die toegang wenst, niet hoeft te betalen voor netwerkbestanddelen of faciliteiten die hij niet nodig acht voor het verstrekken van zijn diensten<sup>47</sup>. Het BIPT zal daarna met de alternatieve operatoren de timing van deze documenten bekijken.

#### 4.4 VERDERE SPECIEFIEKE OPMERKINGEN OVER HET REFERENTIEAANBOD

120. Hieronder worden specifieke opmerkingen van de alternatieve operatoren over de verschillende documenten van het referentieaanbod gebundeld en in tabelvorm besproken.

##### 4.4.1 Annex 1 – General Terms & Conditions

Waar?	Opmerking OLO	Reactie Belgacom	Analyse BIPT
Ann1 §26, Ann4	De alternatieve operatoren vinden dat Belgacom zijn verantwoordelijkheid moet opnemen indien het versleutelingssysteem (CAS) faalt. Deze verantwoordelijkheid uit	De sleutels blijven één maand geldig. Er worden steeds 2 sleutels verstrekt, dus de eindgebruiker kan zeker tot het einde van de volgende maand verder (minstens 1 maand + 1 dag). In principe kan de CAS server dus één	De OLO moet de sleutels ophalen bij Belgacom en bij zichzelf opslagen om aan zijn klanten te verstrekken.  Aangezien de OLO steeds 2 sleutels krijgt die geldig zijn tot het einde van de

<sup>47</sup> Beslissing van de CRC van 1 juli 2011 met betrekking tot de analyse van de breedbandmarkten, r.o. 1158, 340.

	<p>zich onder de vorm van een SLA en KPI die de garantie levert dat de CAS server 99,9% beschikbaar zal zijn.</p> <p>Aangezien Belgacom de beheerder van het systeem is, dat geïmplementeerd werd door verimatrix, is zij verantwoordelijk voor het correct functioneren ervan.</p>	<p>maand down zijn zonder dat dit een impact heeft op de eindgebruikers van de OLO.</p> <p>Belgacom heeft een nieuwe sectie 5.2.4 toegevoegd aan de annex SLA waarin het voorstelt voor de versleutelingsinterface dezelfde SLA timer te gebruiken die voor OAL van toepassing is in het WBA VDSL2 aanbod.</p>	<p>daaropvolgende maand, zal het uitvallen van de CAS server geen direct effect hebben op de eindgebruiker die kan blijven zappen.</p> <p>Er kan enkel een probleem opduiken wanneer de CAS server langer dan één maand onbeschikbaar is. Belgacom moet voor dit uitzonderlijk geval een SLA &amp; compensatie verstrekken.</p> <p>In het kader van deze raadpleging vraagt het BIPT of de voorgestelde SLA tegemoet komt aan de noden van de OLO.</p>
Ann1 §57	<p>De kwaliteit van de gemeenschappelijke televisiesignalen moet door Belgacom gegarandeerd worden want Belgacom is verantwoordelijk voor het transport van het signaal over het Belgacom netwerk.</p>	<p>Belgacom retail garandeert geen beeldkwaliteit, want Belgacom is niet verantwoordelijk voor de beeldkwaliteit die door de contentleverancier aangeboden wordt.</p> <p>Belgacom geeft in het aanbod reeds een SLA op de delen van het netwerk waar zij verantwoordelijk voor is: OAL (netwerk) &amp; distributie gemeenschappelijke zenders (content).</p>	<p>Het BIPT vraagt omwille van transparantie aan Belgacom om deze paragraaf te herformuleren zodat hieruit duidelijk blijkt dat Belgacom wel verantwoordelijkheid opneemt voor OAL (netwerk) &amp; shared channel distributie (content).</p>

#### 4.4.2 Annex 2 – Technical Specifications

Waar?	Opmerking OLO	Reactie Belgacom	Analyse BIPT
Ann2	<p>Belgacom moet bevestigen dat alle zenders, ook diegene die ongecrypteerd worden doorgegeven deel uitmaken van het gemeenschappelijk zenderpakket.</p>	<p>Er zijn geen ongecrypteerde zenders.</p> <p>Het gemeenschappelijk zenderpakket bevat alle zenders, dus de OLO kan toegang krijgen tot alle zenders waarvoor hij de rechten bekomt.</p>	<p>Omwille van transparantie moet Belgacom in het aanbod verduidelijken dat alle zenders die deel uitmaken van het gemeenschappelijk zenderpakket en waarvoor de OLO de rechten kan bekomen, onderdeel uitmaken van dit aanbod.</p>
Ann2 §19	<p>De beschikbare DSL snelheid zou altijd voldoende hoog moeten zijn zodat de omroepsignalen geen impact hebben op de spraakdiensten.</p>	<p>VoIP bevindt zich in een andere VLAN dan multicast TV. Ook de modemuitgang is verschillend. Beide hebben dezelfde prioriteit P3.</p> <p>Om gedropte pakketten te vermijden kan de OLO een resource controller</p>	<p>Zowel TV als spraak hebben een hoge prioriteit P3. In het geval van saturatie zullen internetpakketten, die een lagere prioriteit hebben, gedropt worden.</p> <p>Een OLO kan voor de zekerheid nog een resource</p>

		installeren gelinkt aan een decoder, die beslist hoeveel streams de eindgebruiker krijgt, afhankelijk van de beschikbare capaciteit.	controller gebruiken maar dat lijkt niet noodzakelijk.  Het BIPT ziet geen reden om op dit vlak iets aan te passen.
Ann2 §45 Ann5	Belgacom mag niet eenzijdig de bandbreedtes van de kanalen aanpassen aangezien dit een rechtstreekse impact heeft op de kosten en de business case van de OLO. De OLOs stellen voor om de meerkost dan niet te factureren.	Er zal binnen een paar jaar een evolutie van SD naar HD gebeuren op vraag van de consument.  Het lijkt niet gerechtvaardigd dat dit gratis is voor de OLO aangezien het aanbod kostgeoriënteerd is.  De kostgeoriënteerde tarieven kunnen ook zakken als de nodige capaciteit door een betere encodage verlaagd wordt.	Gezien de mogelijke impact op de business case van de alternatieve operatoren, is het aangewezen dat Belgacom een mogelijke capaciteitsverhoging van zenders ter goedkeuring aan het BIPT voorlegt.  De kostbepaling zullen herzien worden als de capaciteit van een groot aantal zenders verhoogd wordt, want er treden dan meer schaalvoordelen op. Hierdoor zal een globale capaciteitsverhoging niet noodzakelijk aanleiding geven tot een even grote prijsverhoging.  Belgacom is tevens verplicht een notificatietermijn van 2 maanden aan de OLOs te respecteren alvorens de capaciteit te veranderen.

#### 4.4.3 Annex 3 – P&O

Waar?	Opmerking OLO	Reactie Belgacom	Analyse BIPT
Ann3 §173	Een voldoende lange Friendly User Test (FUT) met voldoende eindgebruikers is noodzakelijk voor een vlotte lancering.	De FUT mag langer dan 10 dagen duren.	Belgacom heeft het referentieaanbod aangepast en 20 dagen FUT voorzien.  In het kader van de raadpleging wordt hieromtrent de reactie van de sector gevraagd.

#### 4.4.4 Annex 4 – Service Level Agreements

Waar?	Opmerking OLO	Reactie Belgacom	Analyse BIPT
Ann4 5.1.1.2	Een SLA van 8 werkdagen voor multicast activatie is veel te lang.	8 werkdagen komt overeen met de SLA in WBA VDSL2 voor de procedure "change VLAN".  In de meeste gevallen zal de activatie veel sneller verlopen.	De activatieprocedure voor multicast is gebaseerd op de bestaande VLAN activatie procedure. Die procedure gebeurt deels manueel, waardoor het BIPT in het verleden 8WD heeft toegestaan voor de SLA.
Ann4 §53 §81	Een compensatie per uur is aangewezen want anders is er na het verstrijken van de SLA	Belgacom heeft er alle belang bij om dit probleem bij de shared TV channel zo snel	Aangezien een compensatie voldoende druk moet zetten op Belgacom om het probleem

	repair timer voor de shared TV channel van 4u geen stimulans meer om het probleem snel op te lossen aangezien de compensatie die per werkdag wordt gerekend toch al moet betaald worden.	mogelijk op te lossen aangezien de eigen retailklanten ook geïmpacteerd worden.	op te lossen, is het BIPT van mening dat een compensatie per uur aangewezen is:  "1,5€ per working hour delayed"
Ann4 9.3.1.	De compensatie van 3% van de rental fee per dag is te laag.  Eén maand bestaat uit 21 werkdagen, wat dus slechts maximaal 63% compensatie oplevert voor een maand outage.	In principe heeft Belgacom in de versie van mei 2012 de compensatie aangepast tot "0,5% of monthly recurring fee per working hour".  Echter in de zin boven de tabel, wordt nog altijd de 3% van het oorspronkelijke voorstel naar voren geschoven als compensatie .	Het BIPT vraagt om duidelijkheid te verschaffen over de uiteindelijke compensatie.  Het is een redelijke veronderstelling dat de vermelding van 3% in dit voorstel om een vergetelheid gaat en dat de rental fee door Belgacom volledig wordt terugbetaald in het geval van een outage van een maand.

## 5 BESLUIT

121. Het bovenstaande besluit reikt de elementen aan die gevolgd moeten worden om het multicast-referentieaanbod in overeenstemming te brengen met de reglementaire verplichtingen die Belgacom dient na te leven.
122. Het referentieaanbod op grond waarvan dit besluit werd opgesteld, moet integraal worden aangepast aan de opmerkingen in dit besluit.
123. Belgacom moet de timing van de implementatie zoals voorzien door het marktanalysebesluit respecteren:

*“Het referentieaanbod in verband met het voormelde alternatief voor multicast zal operationeel moeten zijn uiterlijk 6 maanden na het besluit van het BIPT betreffende ten minste de kwalitatieve aspecten van het voorstel voor een referentieaanbod vanwege Belgacom.”<sup>48</sup>*

124. Het BIPT wil hierbij ook benadrukken dat het voor het verdere verloop van de procedure een groot belang hecht aan het correct naleven van de termijnen zoals die in de beslissing van de CRC van 1 juli 2011 geformuleerd zijn. Gezien Belgacom deze alternatieve oplossing zelf heeft voorgesteld, verwacht het BIPT van Belgacom een strikte naleving van de verdere uitvoeringstermijnen. Zoals Belgacom immers zelf stelt in zijn schrijven van 19 september 2011 is dit alternatieve aanbod deels een oplossing om in te gaan op de wensen van de OLO's om zo snel mogelijk een competitief tv-aanbod te kunnen lanceren.

---

<sup>48</sup> Beslissing van de CRC van 1 juli 2011 met betrekking tot de analyse van de breedbandmarkten, r.o. 1109, 326-327.

## 6 BEROEPSMOGELIJKHEDEN

- 125.Overeenkomstig de wet van 17 januari 2003 betreffende de rechtsmiddelen en de geschillenbehandeling naar aanleiding van de wet van 17 januari 2003 met betrekking tot het statuut van de regulator van de Belgische post- en telecommunicatiesector hebt u de mogelijkheid om tegen dit besluit beroep in te stellen bij het hof van beroep van Brussel, Poelaertplein 1, B-1000 Brussel. Het beroep wordt, op straffe van nietigheid die ambtshalve wordt uitgesproken, ingesteld door middel van een ondertekend verzoekschrift dat wordt ingediend ter griffie van het hof van beroep van Brussel binnen een termijn van zestig dagen na de kennisgeving van het besluit of bij gebreke aan een kennisgeving, na de publicatie van het besluit of bij gebreke aan een publicatie, na de kennisname van het besluit.
- 126.Het verzoekschrift wordt ingediend op de griffie van het gerecht in hoger beroep in zoveel exemplaren als er betrokken partijen zijn. Het verzoekschrift bevat op straffe van nietigheid de vermeldingen van artikel 2, § 2, van de wet van 17 januari 2003 betreffende de rechtsmiddelen en de geschillenbehandeling naar aanleiding van de wet van 17 januari 2003 met betrekking tot het statuut van de regulator van de Belgische post- en telecommunicatiesector.

Axel Desmedt  
Lid van de Raad

Charles Cuvelliez  
Lid van de Raad

Catherine Rutten  
Lid van de Raad

Luc Hindryckx  
Voorzitter van de Raad

## **BIJLAGE : REFERENTIEAANBOD**

Op 7 mei 2012 heeft Belgacom deze versie van het referentieaanbod aan het BIPT overgemaakt.

# Wholesale Multicast

## Main Body

Created on: 06 March 2012

belgacom

together with





together  
with



# 1 Table of contents

<b>1</b>	<b>Table of contents .....</b>	<b>2</b>
<b>2</b>	<b>Glossary.....</b>	<b>3</b>
<b>3</b>	<b>Scope of the document .....</b>	<b>4</b>
<b>4</b>	<b>Description of Wholesale Multicast Services .....</b>	<b>5</b>
4.1	General .....	5
4.2	Multicast functionality & Cross-Connect .....	7
4.3	Shared TV Channels.....	8
4.3.1	Encryption.....	9
4.3.2	Encryption Key Interface.....	10
4.3.3	Shared TV Channel Management.....	10
4.4	Shared TV Channel Interface.....	10
4.5	Dedicated Capacity .....	11
4.5.1	Dedicated Capacity Injection Interface.....	11
4.5.2	Dedicated Capacity Bandwidth .....	12
4.5.3	Multicast IP Addresses.....	12
4.5.4	Dedicated Capacity Management.....	12
<b>5</b>	<b>Operational Processes.....</b>	<b>13</b>
<b>6</b>	<b>Pricing and Billing.....</b>	<b>14</b>
◆◆◆◆◆	<b>End of document ◆◆◆◆◆ .....</b>	<b>14</b>

## 2 Glossary

- **Available Dedicated Capacity:** network bandwidth reserved for the Customer at initial set-up for the injection of Dedicated Multicast Streams.
- **Broadcaster:** Is the entity emitting the TV signal captured by Belgacom.
- **Customer Equipment:** Any equipment that belongs to the Customer
- **Dedicated Multicast Stream:** Multicast stream of which the signal is under the Customer's responsibility.
- **Encryption Key Interface:** Interface used between Belgacom encryption system and the Customer's encryption system for the exchange of encryption keys.
- **HD Shared Channel:** High Definition Shared TV Channels. The technical features of a High Definition Shared TV Channel are described in Annex 2 – Technical Specifications.
- **IP-DSLAM:** Digital Subscriber Line Access Multiplexer. IP-DSLAMs are located in Belgacom Local Exchanges and they are owned and managed by Belgacom.
- **IPTV Platform:** Technical platform of Belgacom enabling the broadcaster signals capture and formatting before injection into the Belgacom network.
- **IPTV Product:** Any IPTV solution developed by the Customer and relying on the Wholesale Multicast Services provided by Belgacom.
- **LEX:** Belgacom Local Exchange
- **Multicast functionality:** is considered as the functionality to be activated at IP-DSLAM level on a specific User line for enabling the User's decoder to call any Multicast Stream and receive the corresponding TV stream accordingly.
- **Multicast Stream:** is a stream of data injected into the Belgacom network and accessible for Users benefitting from the multicast functionality on its line. A Multicast Stream can be either a Shared TV Channel or a Dedicated Multicast Stream.
- **NNI:** Network Node Interface.
- **nPVR:** Network Personal Recording
- **OAL:** OLO (Ethernet) Access Line. An Access Line is an interface between the Customer Equipment and a Belgacom Service Router located in the Service PoP of the Service Area.
- **OLO:** Other Licensed Operator
- **Ordered Dedicated Capacity:** network bandwidth ordered by the Customer and effectively provisioned by Belgacom for the injection of Dedicated Multicast Streams.
- **P-bit:** priority bit
- **Radio Shared Channel:** The technical features of a Radio Shared TV Channel are described in Annex 2 – Technical Specifications.
- **Right holders:** Content providers and if applicable the competent collecting societies.
- **Service PoP:** a Service PoP provides access to the Belgacom Ethernet network through NNI connection with a Belgacom Service Router.
- **Shared TV Channel:** Multicast TV Stream formatted in the Belgacom IPTV platform and offered to Customers under the Multicast Offer.
- **Shared TV Channel Pool:** Updated List of Shared TV Channels offered by Belgacom under the Multicast Offer.
- **STB:** stands for Set-Top-Box and is the generic terms used for the decoder to be installed between the signal provided by the network and the television set.
- **User:** is the party to which the Customer is delivering IPTV products.
- **UNI:** User to Network Interface.
- **VDSL2:** VDSL2 is an access service based VDSL2 (Very high Speed Digital Subscriber Line 2) technology that allows simultaneous transport of data and voice service, using the same local exchange service loop, to be sent over existing facilities.
- **VLAN:** Virtual Local Area Network. Unless specified otherwise, the word "VLAN" refers specifically to a shared VLAN.
- **VoD:** Video on Demand
- **WBA:** Wholesale Broadband Access.
- **WBA VDSL2:** Wholesale Broadband Access VDSL2, (shared VLAN only).
- **Wholesale Multicast Services:** The services described in the Multicast Offer, also referred to as the Services.

### 3 Scope of the document

1. This document provides a description of the Wholesale Multicast Services including the method of connection.
2. This document contains the conditions related to the provision by Belgacom to the Customer, of the Wholesale Multicast Services, which will enable the Customer to define its own IPTV Product and to market, distribute and sell under its name and on its behalf its own IPTV products towards Users, using Belgacom's installed and existing network infrastructure and Shared TV Channels, pursuant to the technical limitations of these existing infrastructures for offering the service.
3. This document contains the technical, operational and financial conditions, as well as the applicable terms and conditions related to such a service.
4. The provision of the hereunder-described service supposes the following list of prerequisites that will need to be met at all times and in all circumstances:
  - The Customer has already subscribed to the Belgacom WBA VDSL2 offer.

## 4 Description of Wholesale Multicast Services

### 4.1 General

5. The Wholesale Multicast Services are a set of services enabling the Customer to benefit from the Multicast functionality, Shared TV Channels and Dedicated Capacity.
6. The Wholesale Multicast Services are available as an extension of the Belgacom WBA VDSL2 offer which is considered as a prerequisite to the Multicast Offer.
7. The Wholesale Multicast Services covers:
  - The provision by Belgacom on a specific User line of the multicast functionality enabling the Customer's user to call a given Multicast Stream and to receive it accordingly.
  - The provision by Belgacom of an Encryption Key Interface enabling the Customer to fetch encryption keys of Shared TV channels the Customer subscribed to.
  - A pool of Shared TV Channels which are made available to the Customer's Users via the multicast functionality. In respect to the Shared TV Channels provision Belgacom is responsible for the Shared TV Channel signal capture from the broadcaster, the Multicast Stream encoding and encryption according to Belgacom's encryption method.
  - The Shared TV Channel Pool is made up of SD, HD and Radio Shared Channels.
  - The provision of a Dedicated Capacity Injection interface enabling the Customer to inject in the PIM Core Network its own content.
  - The provision of Multicast IP addresses group dedicated to the Customer.
  - The provision of Dedicated Capacity for the transport of the Customer's dedicated content over the Belgacom network and injected through the Dedicated Capacity Injection Interface. The dedicated content so transported is made available at Customer's User through the multicast functionality.
  - The provision of Shared TV Channels Interface enabling the Customer to receive through an OAL up to its infrastructure all encrypted Shared TV channels it subscribed to. The Shared TV Channels transported so are in the same format (encoding and encryption) as the channels available at user end via the multicast functionality.
8. The Prerequisites for benefitting from Multicast functionality on a given WBA VDSL2 User line are:
  - The Customer must, prior to the activation of Multicast functionality on a given User line have a shared VLAN with service quality P3 available in the LEX where the User is connected to.
  - Subsequently the User line must be configured with a service quality VLAN P3.
9. The prerequisites for benefitting from Shared TV Channels are:

- The User to whom the Customer wants to offer a Shared TV channel must have a WBA VDSL2 line fulfilling requirements stated in previous paragraph.
- The Customer must at least have one OAL ending up in one of following Service PoP, for fetching decryption keys:
  - i. o2STR
  - ii. o2MAR
  - iii. o3CEN
  - iv. o3BKC
- The Customer is responsible for dimensioning the OAL bandwidth so that the Encryption Key Interface is properly working.
- The Customer must have brought the proof that it has been granted the content rights corresponding to the Shared TV channel it wants to order.

10. The prerequisites for benefitting from Dedicated Capacity are:

- The User to whom the Customer wants to offer a Multicast dedicated streams out of its Dedicated Capacity must have a WBA VDSL2 line fulfilling requirements stated in previous paragraph.
- The Customer must have one OAL ending up in o2MAR and one OAL ending up in o2STR.
- The Customer is responsible for dimensioning the OAL bandwidth so that the Dedicated Capacity Interface is properly working.

11. The prerequisites for benefitting from the Shared TV Channel Interface are:

- The Customer must have at least one OAL ending up in one of following Service PoP:
  - i. o2STR
  - ii. o2MAR

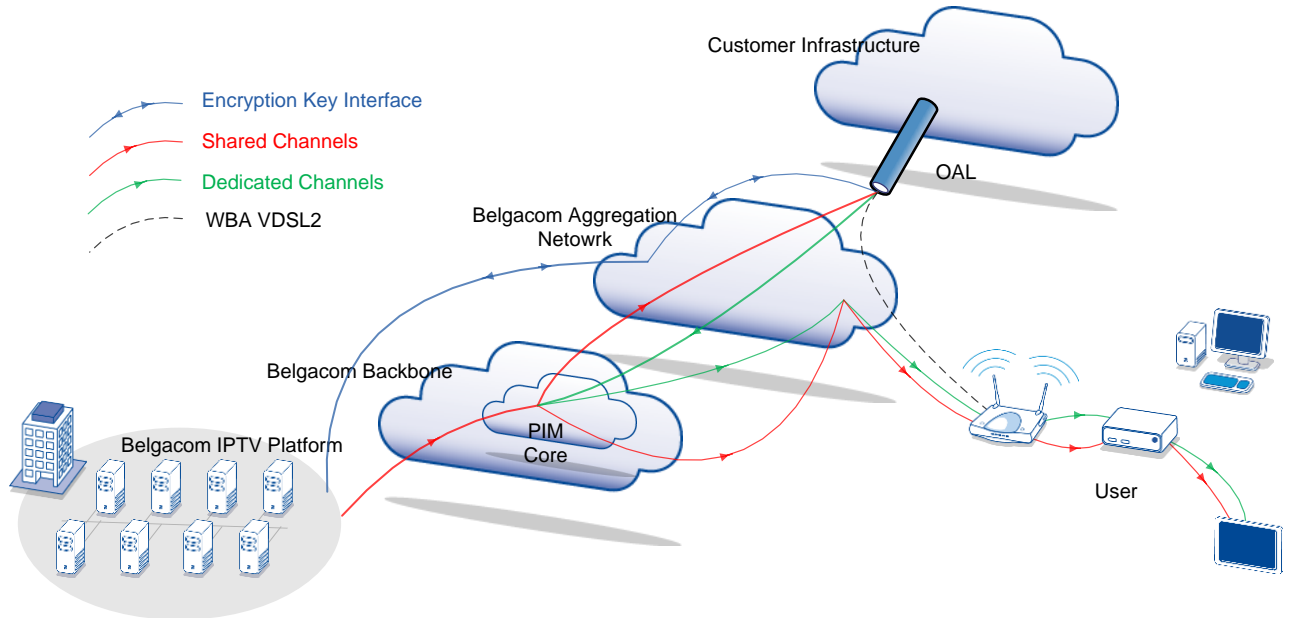

**Figure 1: End-to-End Overview**

12. The figure 1 gives the end-to-end overview of the Wholesale Multicast Services. The Encryption Key Interface allows the Customer upon request to fetch keys of Shared TV channels it subscribed to. The Shared TV Channels are made available at PIM Core level and merged with Customer Multicast Dedicated streams part of its Dedicated Capacity. The Shared TV Channels and the Multicast dedicated streams can be transported up to the Customer infrastructure over the Shared TV Channel Interface. If the Customer's User line has been previously configured with the multicast functionality the Customer's User could call a given channel and receive it. The Customer is responsible for providing its Customer with Shared TV channel encryption keys (fetched via the Encryption Key Interface) through its WBA VDSL2 access.
13. Any TV service not described in the Multicast Offer is under the Customer responsibility.
14. Specifically following services or products are out of the scope of the present offer:
  - Content Rights of Shared TV Channels
  - Set-Top-Boxes
  - Any unicast TV Services (nPVR, VoD, graphical user interface...)

## 4.2 Multicast functionality & Cross-Connect

15. The Multicast functionality is an IP-DSLAM feature enabling the User's STB to call a given Multicast Stream and to receive it accordingly in order to display it on the screen.

16. The multicast functionality alone does not enable the User's STB to decrypt the TV signal so received. The Customer is responsible for providing the User's STB with the encryption keys of its Multicast dedicated streams (assuming they are encrypted) and encryption keys of Shared TV Channels it subscribed to.
17. The multicast functionality enables the User's STB to call at any moment another Multicast Stream by leaving the previous one and calling the new one (Multicast Stream zapping).
18. The Customer can activate the multicast functionality on the WBA VDSL2 line of a given User through the Multicast functionality activation on a WBA VDSL2 line ordering process further described in Annex 2.
19. Belgacom will ensure the cross-connection of the Multicast VLAN and a TV unicast VLAN ordered by the Customer as per the WBA VDSL2 offer. The TV unicast VLAN is the WBA VDSL2 shared VLAN of service quality P3 (not P3bis) intended to transport TV unicast services under the Customer responsibility. To have a shared VLAN P3 is a prerequisite before activating the multicast functionality on the WBA VDSL2 line of the Customer's User.
20. The Customer is responsible for dimensioning its WBA VDSL2 shared VLAN in order to take into account new traffic generated by its TV unicast services.
21. The Customer shall at least order and maintain fifteen Shared TV Channels before Belgacom will accept a Multicast functionality activation on WBA VDSL2 User line. This requirement is here after referred as "the Start-up Pack".
22. The Start-up Pack must be made up of SD and HD Shared TV Channels only. Radio Shared Channels are not considered as qualified for being part of the fifteen channels of the Start-up Pack.

### 4.3 Shared TV Channels

23. Shared TV Channels are Multicast TV Streams offered by Belgacom to the Customers. Belgacom ensures the complete processing chain of Shared TV Channels from the TV signal capture from the Broadcaster up to the injection of the Multicast Stream into the Belgacom Network so that the Multicast Stream is available to Users. This TV processing chain includes the Broadcaster TV signal capture, the TV signal decoding and decryption (decoding and decryption of the signal provided by the broadcaster), the TV Multicast Stream encoding, the TV Multicast Stream encryption with Belgacom encryption key and encryption algorithm deployed at Belgacom and the TV Multicast Stream injection into the Belgacom network.
24. A Shared TV Channel is by definition a channel which is offered by Belgacom to Customers having subscribed to the channel.
25. The pool of Shared TV Channels offered by Belgacom will not include any channel for which Belgacom owns content rights exclusivity.
26. The Shared TV Channel ordering process is further specified in Annex 2.
27. The acquisition of content rights for a given Shared TV Channels is the Customer's responsibility. Belgacom will approve the ordering of a given Shared TV Channel only after a proof has been provided to Belgacom that the Customer has acquired the appropriate content rights.
28. Belgacom offers in its Shared TV Channels pool three types of Shared TV Channels:

- Radio Channels: Audio Content
- SD Channels: Standard Definition Channel
- HD Channels: High Definition Channel

29. The technical features are available in Annex 2 – Technical Specifications.

30. The Customer shall notify Belgacom upfront when a Customer's User intends to resell to or otherwise put the Wholesale Multicast Services at the disposal of a third party.

#### 4.3.1 Encryption

31. A Shared TV Channel is by default available via the multicast functionality to any Customer's User having a Belgacom WBA VDSL2 line and having the multicast functionality activated on it. But the Shared TV Channel is encrypted by Belgacom and can be available in clear only if the User's STB has access to the encryption keys.
32. All Shared Channels provided by Belgacom in the shared channel pool are without exception encrypted.
33. Once the ordering process of a Shared TV Channel is completed Belgacom shall ensure that the encryption key of the Shared TV channel can be fetched by the Customer. The Customer is then responsible for sending the encryption key to the STB of its Users.
34. The Belgacom encryption keys are managed by the Belgacom Content Access Server (CAS). In order to make use of the encryption keys made available by Belgacom the Customer Content Access Server shall be compatible with the Belgacom's CAS.
35. The Customer is responsible for deploying any equipment compatible with the Belgacom Content Access Server and required for making usage of the Encryption Keys provided by Belgacom.
36. A prerequisite for the ordering of Shared TV Channels and the subsequent exchange of encryption keys is the set-up of the Encryption Key Interface. The Customer shall ensure that this prerequisite is fulfilled before any Shared TV Channel ordering.
37. Encryption keys for a given Shared TV Channel are renewed on a regular basis. The Customer shall fetch the encryption keys at a frequency imposed by Belgacom in order to ensure that the Customer has always a valid Encryption Key. Belgacom shall not be hold responsible for any service degradation in case of non-compliance with that requirement.
38. By fetching Encryption Keys the customer fetches all the Encryption Keys it is entitled to and corresponding to Shared TV Channels the Customer subscribed to.
39. The encryption Key renewal date might be different for each Shared TV Channel.
40. Two Encryption Keys are always provided for a given channel while the Customer fetches the Encryption Key for a given Shared TV Channel: the currently valid Encryption Key and the next valid Key.

### 4.3.2 Encryption Key Interface

41. The Encryption Key Interface is a prerequisite to the provisioning of a Shared TV Channel.
42. The Encryption Key Interface is intended to interconnect the Belgacom's CAS and the Customer's CAS.
43. The Encryption Key Interface is made up of following network pieces:
  - A specific VLAN configured on an OAL. The OAL on which the VLAN is configured is left at Customer discretion but must end up on one of the following Service PoP: o2MAR, o2STR, o2CEN or o3BKC. Further information regarding those Service PoP is available in the WBA VDSL2 offer – Main Body.
  - Network configuration required for connecting the VLAN to the Belgacom CAS.

### 4.3.3 Shared TV Channel Management

44. Regarding Shared TV Channels the Customer has subscribed to, Belgacom has the right to remove any Shared TV Channel from the Shared TV Channels pool, provided the Customer has been notified two (2) month before its removal. The considered Shared TV Channel stream will accordingly no longer be provided by Belgacom to the Customer.
45. Regarding Shared TV Channels the Customer has not subscribed to, Belgacom has the right in any case to remove the Shared TV Channels from the Shared TV Channel pool without any obligation to notify the Customer. The considered Shared TV Channel stream will accordingly no longer be provided by Belgacom.
46. A Shared TV Channel to be removed from the Shared TV Channels pool will be removed from the list of Shared TV Channels available on the Belgacom secured website two (2) months before its actual stop.
47. Belgacom has the right to reject the ordering of a given Shared TV Channel if it is known that it will be removed within two (2) months following the ordering notification by the Customer.
48. Belgacom has the right to add a Shared TV Channel to the Shared TV Channel pool. This Shared TV Channel will be available for ordering by the Customer.

## 4.4 Shared TV Channel Interface

49. The Shared TV Channel Interface is aimed at providing the Customer with an interface enabling the transport of all Shared TV Channels the Customer subscribed to through an OAL up to the Customer's infrastructure.
50. The Shared TV Channel interface consists in a specific VLAN configured on the OAL specified by the Customer
51. It is up to the Customer to decide if the Shared TV Channel Interface must be redundant.
52. The Customer is responsible for dimensioning the OAL the Shared TV Channels streams will flow over. Belgacom shall not be hold responsible for any stream quality issue due to a bandwidth shortage on the considered OAL.

53. All Shared TV Channels transported over the Shared TV Channel Interface are encrypted and in the same format as the Shared TV Channels made available to the Customer's Users provided the Customer has subscribed to.

## 4.5 Dedicated Capacity

54. The Dedicated Capacity is an optional feature aimed at providing the Customer with the capability to inject its own multicast streams into the Belgacom Network.
55. The Dedicated Capacity is made up of:
- Bandwidth in the Belgacom network. The bandwidth ordering can be done either at the initial set-up of multicast or later depending on the Customer's needs and the available bandwidth.
    - i. Initial set-up: The Customer can order up to 25 000 Kbps (Available Dedicated Capacity at initial launch) or less. If the Customer orders less than 25 000 Kbps, Belgacom will make the remaining capacity free so that it could be ordered by anyone else according to a fair split between requestors.
    - ii. Later: There is no guarantee about the feasibility of a dedicated capacity request. Belgacom will assess the request depending on the capacity still available in the network and independently of the Available Dedicated Capacity.
  - A Dedicated Capacity Injection Interface aimed at interfacing the Customer's infrastructure and the Belgacom network.

### 4.5.1 Dedicated Capacity Injection Interface

56. The Dedicated Capacity Injection Interface must be redundant.
57. Before Belgacom can provision the Dedicated Capacity Injection Interface the Customer must ensure that it has two OAL ending up on Service PoP O2MAR and Service PoP O2STR. This is a prerequisite prior to the setup of the Dedicated Capacity Injection Interface.
58. Belgacom shall configure on both OAL a specific VLAN dedicated to the transport of Customer Multicast streams.
59. The VLAN bandwidth is capped at the Ordered Dedicated Capacity. Through shaping configuration Belgacom reserves the rights to drop any packet making the total bandwidth beyond the Ordered Dedicated Capacity.
60. The Customer is responsible for ensuring the total bandwidth used by the multicast streams flowing over the Dedicated Capacity Injection Interface does not exceed the Ordered Dedicated Capacity
61. Belgacom shall not be held responsible for a multicast stream quality issue if the bandwidth injected by the Customer goes over the Ordered Dedicated Capacity and packets are as a consequence dropped.
62. The Customer is responsible for ensuring the appropriate OAL bandwidth dimensioning so that the Customer's multicast streams can flow over the OAL without any risk of packet drop impacting the multicast stream quality.

63. Belgacom shall not be hold responsible for any multicast stream quality issue due to capacity saturation on the Customer's OAL's.

#### 4.5.2 Dedicated Capacity Bandwidth

64. Included in the Dedicated Capacity is a reserved bandwidth as ordered by the Customer in the Belgacom network from the Belgacom backbone/PIM core, where all multicast streams including the Shared TV channels and the Customer's streams are present, up to the IP-DSLAM.
65. This bandwidth is capped downstream at Dedicated Capacity Injection Interface level as further explained in paragraph above.

#### 4.5.3 Multicast IP Adresses

66. Belgacom will provide the Customer with a set of 32 Multicast IP addresses corresponding to 32 Multicast streams.
67. The Customer shall specify the bandwidth allocated to each of the 32 Multicast streams.
68. The Sum of bandwidths allocated to each multicast IP address can be greater than the Ordered Dedicated Capacity without changing that limitation. The Customer is responsible for injecting streams so that the total bandwidth injected into Belgacom network does not go over the Ordered Dedicated Capacity as specified in paragraph 4.5.1.
69. The Customer's allocated multicast IP addresses and corresponding bandwidth is configured in all Belgacom network IP-DSLAM's.
70. Belgacom offers the Customer the possibility to perform two changes a year at fixed date. Such a change includes a modification of the bandwidth allocated to each multicast IP address.

#### 4.5.4 Dedicated Capacity Management

71. The overall multicast capacity will be reviewed one year after the Customer officially launched its IPTV product based upon the Wholesale Multicast Services.
72. Based upon Belgacom forecasts and the IPTV market status an extension of the Customer's Dedicated Capacity bandwidth will be assessed and capacity reserved but not allocated yet could be redistributed amongst Belgacom and Customers having subscribed to the Wholesale Multicast Offer.

## 5 Operational Processes

73. The provisioning and repair processes for the Wholesale Multicast Services are detailed in the Annex 3 , Planning and Operations.

## 6 Pricing and Billing

74. Principle: all Standard Fees as described in Annex 5, Pricing and Billing, will be invoiced to and are to be paid by the Customer whenever relevant.
75. The Customer will receive a monthly invoice containing the fees (recurring and non-recurring) for that period. Invoices related to any relevant fees are to be paid within the foreseen deadlines as set out in the Annex 5, Pricing & Billing document.

◆◆◆◆◆ End of document ◆◆◆◆◆

Wholesale Multicast

# Annex 1: General Terms & Conditions

Created on: 06/03/2012

belgacom

together with



## **General information**

This document constitutes an integral part of the Wholesale Multicast Services Offer (hereafter referred to as the “MULTICAST Offer”) communicated to the Belgian Institute for Post and Telecom (here-after the BIPT). It includes the general terms and conditions applicable to the provision of Wholesale Multicast Services offered as an option on Belgacom Wholesale Broadband Access VDSL2. These Wholesale Multicast Services are provided in conformity with the relevant laws and decrees in effect. The present Terms and Conditions shall remain applicable until they are replaced by other terms and conditions.

A distinction should be made between the following:

### **The Main Body**

This document describes in broad terms the conditions of the Wholesale Multicast Services offered by Belgacom as it has been communicated to the BIPT.

### **The Annex 1, “General Terms and Conditions”**

The General Terms and Conditions list the rights and obligations of Belgacom and the Customer with regard to the provision of the Wholesale Multicast Services.

### **The Annex 2, “Technical Specifications”**

The technical conditions define the technical specifications and the quality standards of the Wholesale Multicast Services.

### **The Annex 3, “Planning & Operations”**

The Planning & Operations Manual describes the conditions of delivery of the Wholesale Multicast Services.

### **The Annex 4, “Multicast Service Level Agreement”**

The Multicast Service Level Agreement defines the Terms and Conditions upon which Belgacom will deliver installation and maintenance for the Wholesale Multicast Services.

### **The Annex 5, “Pricing and Billing”**

The Pricing and Billing indicates the rates and the billing and payment conditions for the Wholesale Multicast Services.

### **The Annex 6, “Prepayment Terms & Conditions”**

\*\*\*



The General Terms and Conditions, Main Body, Technical Specifications, Planning and Operations, Service Level Agreement, Pricing and Billing, Prepayment Terms and Conditions jointly constitute the Wholesale Multicast Services Offer (hereinafter, the “MULTICAST Offer”).

\*\*\*

Anyone may examine the Main Body and Annexes of the MULTICAST Offer, as they are approved by BIPT and applicable at the time of consultation. These are available on Belgacom’s Internet site. Other documents which are referenced in the Main Body or Annexes are available on the Secured website of Belgacom (Personal Page of Belgacom Wholesale) and may be consulted further to the signature of a non-disclosure agreement.



together  
with



# 1 Glossary

The capitalized terms in the present General Terms and Conditions for Wholesale Multicast Services have the meaning as defined below:

Contract	A contract for the provision of a Wholesale Multicast Service according to the terms and conditions of the MULTICAST Offer, and, if any, the specific terms and conditions agreed upon by the Parties. The Contract is concluded as mentioned in article 6 below. Except otherwise agreed by the Parties, the Contract shall be adapted if the MULTICAST Offer is modified. This adaptation shall be in accordance with this MULTICAST Offer's modification.
Customer	An operator (as defined by art. 2, 11° Law of 13 June 2005 on electronic communications) who has concluded one or more Contracts with Belgacom.
Dedicated Capacity	Network bandwidth reserved for the Customer for the injection of Dedicated Multicast Streams.
Dedicated Multicast Stream	Multicast stream of which the signal is under the Customer's responsibility.
IPTV Platform	Technical platform of Belgacom enabling the broadcaster signals capture and formatting before injection into the Belgacom network.
IPTV Product	Any IPTV solution developed by the Customer and relying on the Wholesale Multicast Services provided by Belgacom.
Party	Either Belgacom or Customer.
Parties	Collectively, Belgacom and Customer.
Request	The Customer's demand concerning the delivery of a Wholesale Multicast Service as described in this Offer.
Right holders	Content providers and, if applicable, the competent collecting societies.
Shared TV channel	Multicast TV stream formatted in the Belgacom IPTV Platform and offered to Customers under the MULTICAST Offer; an updated list of Shared TV channels ("Shared TV channel Pool") can be found on the Personal Page of the Belgacom Wholesale website
User	Any direct customer of the Customer.
Wholesale Multicast Services	The services described in the MULTICAST Offer, also referred to as "the Service(s)".

## 2 Contract procedure

### 2.1 Request by the Customer

1. In view of the offering of an IPTV Product to his Users, the Customer must submit his Request for a Service to the Wholesale department of Belgacom by completing and signing the appropriate order form or submitting an order request in electronic format (depending on the type of Service), pursuant to the rules described in the Annex 3 “Planning & Operations”. The terms and conditions for delivering the Services are described here-after.
2. The Customer shall consult the Main Body, the General Terms and Conditions, the list of technical requirements, as well as the other annexes of the MULTICAST Offer.
3. Belgacom may not refuse to execute the Customer's Request conform the MULTICAST Offer, without prejudice to the negotiations between Belgacom and the Customer, except on one of the following grounds:
  - a) the Customer or his authorized agent refuses to provide Belgacom with official documents to identify himself;
  - b) in an emergency situation (i.e. exceptional cases of force majeure as defined hereafter), for the purpose of ensuring the safe operation of the Belgacom network and equipments (including the Belgacom IPTV Platform);
  - c) following the Customer's failure to observe obligations arising from the present General Terms and Conditions for the use of the Service;
  - d) for the purpose of maintaining Belgacom network integrity or the interoperability of the services or for any other technical reasons that make the delivery of the Service impossible;
  - e) the Customer has refused to provide proof of the existence of the unconditional financial guarantee as specified in the provision Financial Guarantees here-under;
  - f) the Customer's Request for access to the Wholesale Multicast Service is unreasonable (in accordance with paragraph 1106 of the CRC decision of July 1<sup>st</sup>, 2011 regarding the analysis of the broadband markets) on the basis of other grounds than the ones listed hereabove;
  - g) the necessary WBA VDSL2 services as described in Annex 2 “Technical Specifications” are not in place or not installed on behalf of the Customer;
  - h) the Customer has not acquired all appropriate intellectual property rights and authorisations regarding the content/encrypted signal as foreseen in article 18 below.
4. In the event of a refusal on one of the grounds listed in article 3 above, Belgacom shall notify within 3 working days the Customer of its decision and the grounds for the decision by ordinary mail. A copy will be sent to the BIPT in the same delay.
5. The Customer may lodge an appeal against this decision by the procedure provided under the Dispute Resolution Procedure and in accordance with these General Terms and Conditions.

## 2.2 Conclusion, entry into force and duration of the Contract

6. The provision of the Wholesale Multicast Service is subject to the conclusion of a Contract between Customer and Belgacom. The Contract is concluded when Belgacom has accepted in writing or via electronic way (“Validate” XML), depending on the type of Service (see the rules described in Annex 3 “Planning & Operations”), the Order Form submitted by the Customer.
7. Unless otherwise stipulated, the Contract takes effect on the day after the date on which the Wholesale Multicast Service is made available to the Customer. Belgacom shall confirm this date to the Customer in writing, or via electronic way (“Done” XML).
8. The Service is made available to the Customer for an indefinite term.

### 3 Services covered by these General Terms and Conditions

9. Belgacom shall provide to Customer and maintain on behalf of Customer Wholesale Multicast Services in accordance with the MULTICAST Offer.
10. Subject to the successful completion of testing as defined in and pursuant to the provisions of the MULTICAST Offer, the Parties will bring the Multicast Services into service on the agreed Bringing into Service Date.
11. The Wholesale Multicast Services shall be implemented in accordance with the technical specifications in Annex 2 “Technical Specifications”.
12. The Wholesale Multicast Services purchased by Customer according to the foregoing will enable Customer to define its own IPTV Products and to market, distribute and sell under its name and on its behalf its own IPTV Products towards his Users. In this respect Belgacom will inform the Customer of any modification of the technical specification, enabling a modification of the services offered, at the latest 3 (three) months before the commercial launch by Belgacom of a commercial service based on these technical specifications.
13. For each User to whom Customer will sell an IPTV Product in accordance with the foregoing, Belgacom will, in accordance with and subject to the limitation set out in the MULTICAST Offer, activate the multicast functionality on the WBA VDSL2 line of the User and offer the possibility to decrypt a specific set of shared TV channels through the provisioning of encryption keys to the Customer. As an option, the Customer can acquire, in accordance with and subject to the limitation set out in the MULTICAST Offer, Dedicated Capacity enabling the Customer to inject his own content in the Belgacom network.
14. Within the limits of what is permitted under the applicable regulatory framework, both Parties shall exchange appropriate operational information as provided in the MULTICAST Offer (including but not limited, in particular, maintenance contact numbers, network information, information required to comply with law enforcement and other security agencies of the government and such other information as the Parties shall mutually agree).

## 4 Obligations of the Parties

### 4.1 Obligations of the Customer

15. The Customer is at all times fully responsible for ordering on his behalf, according to the WBA VDSL2 Offer, the WBA VDSL2 services required to support the Wholesale Multicast Services as specified in Annex 2 “Technical Specifications” of the MULTICAST Offer (i.e. the connectivity from the User premises up to the demarcation point between Belgacom network and Customer network), prior to the ordering of Wholesale Multicast Services.
16. The Customer is also responsible for the following:
  - To inform Belgacom immediately and in writing of any change that may have an impact on the Belgacom network and equipments (including the Belgacom IPTV Platform) integrity, or on the performance of other services delivered by Belgacom towards End-Users. The present rule does not imply that such changes can be made by the Customer independently;
  - To use the Belgacom network and equipments (including the Belgacom IPTV Platform) in conformity with the prevailing regulations on telecommunications and data protection and in conformity with the applicable law in general and especially the normal behaviour of a professional Customer;
  - To ensure that his Users behave in a manner that is fully compatible with these elements and take also responsibility for such behaviour;
  - To comply with the instructions that Belgacom may issue to the Customer from time to time to ensure the security and correct operation of the Belgacom network and equipments (including the Belgacom IPTV Platform).
17. In respect of the necessary interventions of Belgacom, the Customer will communicate in good faith to Belgacom, in relevant cases and in a sufficiently timely and complete manner, all information needed by Belgacom for performing repair on the deliverables set up in the frame of the MULTICAST Offer. Customer may refuse to communicate confidential data for which Customer motivates it is not relevant for the requested purpose. Belgacom may ask to BIPT the communication of this data if Belgacom is able to prove his need to obtain this information.
18. In respect of the offering of an IPTV Product to his Users based on a Wholesale Multicast Service delivered by Belgacom pursuant to the provisions of the Contract, Customer is responsible:
  - To seek and take all the prior arrangements with the Right holders to authorize and enable Belgacom to act as the technical facility on behalf of Customer in the framework of the Contract(s); this means for example that the Customer shall be responsible for obtaining all and any authorisation from the Right holders to allow Belgacom to lawfully use the signal and/or encrypted content that Belgacom has received to execute its own distribution activities, and for which the Customer has requested the activation by provision of encryption keys, in order to carry on the technical facilities missions arising from the delivery of Wholesale Multicast Services on behalf of the Customer;
  - For acquiring all appropriate intellectual property rights and authorisations regarding the content used in the context of delivering Wholesale Multicast Services to Customer; Customer guarantees that he is duly authorised by the Right holders to use the content for which he has requested from Belgacom to make the signal available;
  - To obtain commitment from these content providers that they will not cut the signal of the Shared TV channel concerned towards Belgacom because of non compliance by Customer of his obligations in the contract with the content provider;
  - Customer shall bring proof of these authorisations at the moment of Request for activation of the shared TV channel(s) concerned, and later during implementation of the Contract, at the request of Belgacom;
  - To maintain these authorisations for the duration of the Contract(s), and make sure that these authorisations are updated in conformity with any change in the Wholesale Multicast Services;

- To communicate to Belgacom orders for the activation of a minimum set of Shared TV channels (see Main body, “Start-up Pack”), and additional Shared TV channels as desired, corresponding to the provision of the encryption keys related to the requested channels, as well as orders for related services, such as for example the necessary interface configuration for enabling the provisioning of encryption keys (see details in Annex 3 “Planning & Operations”);
- In order to make use of the encryption keys of Belgacom the Customer must foresee an environment which is compatible with the content protection system deployed by Belgacom, i.e. Verimatrix (see Annex 2 “Technical Specifications”);
- To communicate to Belgacom orders for the activation of the multicast functionality on the WBA VDSL2 line of the User(s); these orders will only be accepted if the Customer orders and maintains the activation of a minimum set of Shared TV channels (see Main body, “Start-up Pack”);
- To communicate to Belgacom, as an option on the orders for the activation of Shared TV channels, orders for the provisioning of Dedicated Capacity (within the limitations set forth in “2 Technical Specifications”) enabling the Customer to inject his Dedicated Multicast Streams in the Belgacom network, as well as orders for related services, such as for example the necessary interface configuration for enabling the injection of Dedicated Multicast Streams;
- To communicate to Belgacom an optional order for an interface configuration enabling the Customer to receive, simultaneously, all the encrypted Shared TV Channels which have been activated on his behalf; to ensure that these signals are only used to offer additional services to his Users in support of the Wholesale Multicast Services and are transported via the WBA VDSL2 line of the User;
- To ensure accurate communication of Users’ information to Belgacom in accordance with the relevant provisions of the Contract;
- To ensure the marketing, selling, distribution of his own IPTV Products in conformity with the present Terms and Conditions, as well as the billing and collection of the fees to be charged to his Users, without this affecting the Customer’s liability towards Belgacom;
- To inform Belgacom upfront when a Customer’s User intends to resell to or otherwise put the Wholesale Multicast Services at the disposal of a third party, so that the correct fees for the use of Shared TV channels can be applied (see Annex 5 “Pricing and Billing”);
- To communicate Wholesale Multicast Service related problems to Belgacom; however, to ensure that first all appropriate investigations on User, Customer and broadcaster side have been carried out before raising an issue towards Belgacom;
- To handle responsibility related to network, equipment or signal issues that aren’t related to Belgacom;
- To be the single and only point of contact of his Users with regard to the IPTV Products offered by the Customer to hisUsers, and abstain from redirecting this User towards Belgacom in any circumstance for any problem related to the IPTV Products or the Wholesale Multicast Services;
- To ensure that his Users cannot receive more multicast streams than their respective User line profile allows;
- To ensure that the total volume of Dedicated Multicast Streams injected by the Customer in the Belgacom network is in accordance with the limitations set forth in Annex 2 “Technical Specifications”; any volume exceeding these limitations will be dropped by the Belgacom network;
- To use the Wholesale Multicast Services, including Dedicated Capacity, only for the offering of IPTV Products;
- To ensure by the Customer, or to have the latter impose on hisUsers, to use a Decoder which is compliant with the requirements in Annex 2 “Technical Specifications” of the MULTICAST Offer;
- To pay to Belgacom the prices pursuant to the Contract.

## 4.2 Obligations of Belgacom

19. Belgacom will accept the Order and provide the Wholesale Multicast Services, as described in the MULTICAST Offer, insofar the conditions and limitations described in the present General Terms and Conditions and the MULTICAST Offer are respected.
20. For instance, Belgacom reserves the right to reject a particular Order of the Customer:
  - If Belgacom has determined that a specific User line does not fulfill the appropriate technical requirements (see Annex 2 “Technical Specifications”: e.g. VDSL2 technology, service quality P3 configured on the line);
  - The Customer has not not submitted an appropriate order form/request in conformity with the rules described in the Annex 3 “Planning & Operations”;

- The Wholesale Multicast Services ordered are not technically feasible over existing facilities; e.g. there is no free capacity left for injection of Dedicated Multicast Streams in the Belgacom network (see limitations described in Annex 2 “Technical Specifications”);
- The Request for implementation of Wholesale Multicast Services is based on wrong data which do not allow Belgacom to identify the Request or User line unmistakably and provide the Wholesale Multicast Service.

In such cases, Belgacom will communicate to the Customer the reason why the Order/Request has been rejected.

21. Belgacom will provide and maintain the IPTV Platform on behalf of the Customer as regards the Customer’s access to Shared TV channels. In this respect, Belgacom and Belgacom only will be entitled to carry out physical modifications to the Belgacom network or equipments.
22. Belgacom shall respect all service levels, timers and other guarantees mentioned in the Multicast Service Level Agreement, or otherwise shall conform to the applicable penalties.
23. Belgacom is master of its TV channels portfolio. This means that Belgacom is free to add and/or stop the distribution of specific Shared TV channels at its own discretion, in conformity with its retail offer. This means also that Belgacom is entitled to not include certain TV channels in the Shared TV channels Pool under the MULTICAST Offer, and to reserve the distribution of these TV channels exclusively to its retail customers because Belgacom is the editor of the TV channel or has acquired exclusivity rights on the distribution of these TV channels.
24. In the event Belgacom decides to stop the distribution of a specific Shared TV channel, the signal concerned will no longer be available; the Customer who wishes to continue using the signal can decide to inject this signal in the Belgacom network via his own IPTV Platform as part of his Dedicated Capacity (subject to the limitations described in “ 2 Technical Specifications”). Belgacom will inform the Customer, who had access to this signal, with at least 2 months prior written notice of its termination.
25. In the event Belgacom decides to add the distribution of a specific Shared TV channel, the Customer will be informed with at least 2 months prior written notice of the date upon which such signal becomes available to Belgacom’s retail customers, subject to the signature of a non-disclosure agreement.
26. Belgacom will provide the Customer with the encryption keys related to the requested Shared TV channels. Belgacom grants the Customer the right to use, copy and distribute these encryption keys for installation on the decoder of his Users who are end-user of the Customer’s IPTV Product. When a Customer’s User intends to resell or otherwise provide access to the Shared TV channel to a third party, Customer will inform Belgacom, who will, upon explicit request of the Customer, extend the usage right of Customer with a right to use, copy and distribute the relevant encryption keys for installation on the decoder of the end-users of the User concerned, subject to the payment by Customer of the correct fees for the reselling of Shared TV channels (see Annex 5 “Pricing and Billing”).
27. Belgacom has subscribed to and has implemented a content protection system provided by Verimatrix which offers a state of the art solution, as recognized and accepted by the Customer. To avoid any misunderstanding, in no case, Belgacom shall be held liable if the content protection system implemented by Belgacom would fail to perform the functions such technologies were designed to perform and consequently shows some inefficiency to protect the content.

## 5 Financial Conditions

### 5.1 Billing and Payments

28. In consideration for the Wholesale Multicast Services provided by Belgacom under the Contract, Customer shall pay the charges and fees provided in the MULTICAST Offer.

### 5.2 Financial Guarantees

#### 5.2.1 General Principle - Pre-payment

29. Notwithstanding anything to the contrary in the Contract, in order to guarantee the payment by the Customer of the prices due for Services provided by Belgacom that are invoiced on a monthly basis under the Contract, the Customer will provide Belgacom with a monthly pre-payment based on the average of the monthly amount due by the Customer. The amount of the pre-payment shall be based on the average of the invoices issued by Belgacom during three months for the Services ordered in accordance with the Contract. The amount of the pre-payment shall be reviewed every three months. The terms and conditions of this prepayment are described in Annex 6 “Prepayment Terms and Conditions”.
30. In addition, the customer will provide an additional guarantee equal to two months of pre payment. Belgacom reserves the right to require from the Customer the immediate adaptation of this additional guarantee at any time if and when the amount of the monthly prepayment increases.
31. Without prejudice to any other legal or contractual remedies and notwithstanding anything to the contrary in the Contract , in the event Customer fails to pay in due time any undisputed amount due under the pre-payment conditions as defined in the present section and in Annex 6 “Prepayment Terms and Conditions”, Belgacom shall be entitled to execute the following alternatives until full payment is made:
- suspension of any SLA obligations;
  - refusal in writing of any new Order;
  - suspension of the existing Services in accordance with article 822 hereafter.

#### 5.2.2 Sufficient Creditworthiness

32. This monthly pre-payment will not be required in the following circumstances.
33. The Customer has sufficient creditworthiness as evidenced by either of the following alternatives:
- the Customer has obtained a “Ba2” rating or above for its debt (Moody’s); or
  - the Customer has obtained a rating similar to Moody’s “Ba2” rating, provided that (i) such rating is generally accepted by the market as giving similar reliability as Moody’s, (ii) such rating is reviewed and updated on a regular basis.

34. In the event that the Customer would lose the above described creditworthiness at some point in time (either through the loss of “Ba2” credit rating or similar, or upon the occurrence of any default or delay of payment), Customer will have to provide Belgacom with a pre-payment or with another financial guarantee as defined in the present chapter within 10 working days of Belgacom’s request thereto.

### 5.2.3 Other Financial Guarantees

35. The Customer obtains an irrevocable and unconditional parent corporation guarantee for the debts incurred by the Customer for the Services ordered in accordance with the Contract provided that such parent company is issued by a company that has sufficient creditworthiness as defined above. In the event that the Parent Company would lose the above described credit worthiness at some point in time, the Customer will provide Belgacom with a pre-payment or with another financial guarantee as described in the present article within 10 working days of the request of Belgacom.
36. The Customer has constituted a Deposit on an escrow account with a reputable bank or financial institution established in the EU. The amount of that deposit will be equal to an estimate of three months of invoices due by the Customer for the Services ordered in accordance with the Contract. Based on the actual evolution of the amounts due for the Services, the Customer and Belgacom will have the right to require an adaptation of the amount of the deposit every three months. Upon the request for adaptation of the amount of deposit, necessary steps will be taken to ensure adaptation within ten (10) working days. In case of default by the Customer to pay sums due under the Contract, the sums deposited on the escrow account will accrue to Belgacom. The interests accrued on the escrow account will be payable to the Customer. In the event the sums deposited are accrued to Belgacom, or if the amount of the deposit is not adapted despite Belgacom’s request thereto, Customer will provide Belgacom with a pre-payment or with another financial guarantee as defined in the present article within 10 working days of the request of Belgacom.
37. The Customer has provided Belgacom with a irrevocable and unconditional bank guarantee on first demand issued by a reputable bank or financial institution established in the EU. That bank guarantee will be issued for a minimum period of three years and for an amount equal to an estimate of three months of amounts due by the Customer for the Services ordered in accordance with the Contract. Based on the evolution of the amounts due for the Services, Customer and Belgacom will have the right to require an adaptation of the amount of the bank guarantee every three months. Upon the request for adaptation of the amount of bank guarantee, necessary steps will be taken to ensure adaptation within ten (10) working days. Upon expiration of the bank guarantee or after Belgacom has called upon the bank guarantee, or if the amount of the bank guarantee is not adapted despite Belgacom’s request thereto, the Customer shall provide Belgacom with a pre-payment or with another financial guarantee as defined in the present article within 10 working days of the request of Belgacom.
38. The type of Financial Guarantee, which shall be provided by the Customer prior to submitting his Request for a Service, will be agreed upon between Parties and indicated in a formal confirmation letter signed between Parties.

## 6 Principles

### 6.1 Retail Pricing & Billing

39. Customer shall be responsible for the setting of the tariffs that Customer will apply to the Users to whom Customer will sell an IPTV Product based on the Wholesale Multicast Services, as well as for the billing and invoicing of such Users.
40. No deductions or reductions shall be made from the payment of any charges or fees due for the Services for any bad or unpaid debts or any unrecoverable claims (including, in particular, claims arising from fraud cases) that Customer may have against his Users or any other third parties in relation with these Services.

### 6.2 Branding

41. The Parties agree not to offer any service under any brand, including any trademark, trade name or company name, of the other Party unless the use of the brand(s) of the other Party is explicitly provided under the Contract. Such use of the brand will then be strictly limited to the service at stake.
42. Customer shall offer IPTV Products to Users under his own brand without any use of, or reference to Belgacom's brands.

### 6.3 User Terms and Conditions

43. Customer shall cause the terms and conditions governing Customer's contractual relationships with the Users to be compliant with the rules and principles set out in the MULTICAST Offer. Notwithstanding the above, nothing in the present Reference Offer can be construed as creating or evidencing a contractual relationship of any kind between Belgacom and Customer's Users or as providing to Belgacom any right to consult the contracts signed between Customer and his Users.
44. Customer shall indemnify Belgacom against all losses, claims or liability suffered by Belgacom due to the fact that Customer will have failed to incorporate the above mentioned rules and principles in his terms and conditions.

## 7 Coordination between the Parties

### 7.1 Single Points of Contact

45. Each of the Parties will both appoint an individual as its respective single point of contact (“SPOC”) who will act, within the organization of such Party, as the other Party’s contact person.
46. The SPOC of either Party will have full authority to act and decide on behalf of the respective Party on all technical and operational matters regarding the day-to-day management of the performance of their Multicast Contracts. All the decisions taken by any working group constituted by the Parties during the performance of this Multicast Contracts will need to be expressly and formally validated by the SPOC of either Party to be binding on such Party. Except as otherwise expressly provided by the relevant Party, each Party’s SPOC will have no authority to modify the conditions described in the Contract, or to act outside the day-to-day management of the performance of the Services.
47. Notwithstanding anything to the contrary in the foregoing, each Party will be authorized to replace its SPOC by notice sent to the other Party. Such notice will have immediate effect.

### 7.2 Working Group

48. The Parties will be free to set up any other working group in charge of discussing and agreeing on any technical or operational issue as the Parties may deem fit in the performance of the Services.

## 8 Liability

### 8.1 General rules

49. Taking into account the nature of the respective activities of the Parties, the risks and potential profits associated with these activities and the consideration obtained by each Party from the Contract, Parties expressly agree that their respective liability shall be limited as follows.
50. If either Party is held liable to the other Party under the Contract, that liability shall be limited to the following:
  - if such liability results from any personal injury or death incurred as a direct result of the non-performance of the relevant Party's obligations under the Contract, then such liability shall be only subject to the limitation provided in article 51;
  - if such liability results from any conduct attributable to the relevant Party, which is, under Belgian law, characterized as being gross negligence (*faute lourde – zware fout*) or intentional negligence (*dol – bedrog*), then such liability shall be subject to no limitation, except as permitted by law;
  - if such liability results from any material damage (including any dysfunction of the Belgacom's Network), other than those referred to above, arising out of or in any way connected with the performance by the relevant Party of the Services or the breach of such Party's obligations under these Terms and Conditions, then the total amount which can be recovered from such Party for all acts or omissions shall, in no event, exceed an aggregate amount equal to EUR 1,250,000 (one million two hundred fifty thousand euro), subject to the limitation provided in article 51.
51. Neither Party shall be liable for indirect damages (pure and consequential), including without limitation loss of profit, loss of revenue, loss of data, loss of use, loss of savings, loss of goodwill, interruption of business or claim by third parties.

### 8.2 Specific rules

52. Customer will indemnify Belgacom against any claim or loss related to the illegal use, or the use for illegal purpose of the Wholesale Multicast Services by Customer, Customer's Users or by any person using the Wholesale Multicast Services.
53. Customer will indemnify Belgacom for any damage that the use of the Wholesale Multicast Services by the Customer, Customer's Users or by any person using the Wholesale Multicast Services would cause for Belgacom, its customers, or the functioning of its network and equipments (including the Belgacom IPTV Platform).
54. Belgacom is not responsible for the use made by the Customer or his Users of the encryption keys provided by Belgacom. Customer will indemnify Belgacom from any claim by any third party (including competent authorities or any Right holders) related to the use made of the encryption keys.
55. Customer recognises and accepts that Belgacom shall only act as a technical facility ('mere conduit') for handling/supplying the content/signal requested by the Customer. The Customer acknowledges that Belgacom shall not be held responsible for any claim by any third party (including competent authorities or any Right holders) related to the use, transmission or manipulation of the content/signal when delivering the Wholesale Multicast Services. The Customer shall hold Belgacom harmless from any such claim and indemnify Belgacom for any costs or damages it has incurred following such claim.
56. Customer will also indemnify Belgacom from any claim by any third party (including Right holders or Users of Customer) following the termination of the offering of a particular Shared TV channel/signal.

57. Customer recognises and accepts that Belgacom is not responsible for the quality of the signal of the Shared TV channel, except for the formatting of the broadcaster's signal (i.e. decryption and decoding of the broadcaster's signal, encoding according to the video standard and encryption of the signal by Belgacom). Customer will forward a direct claim towards the broadcaster in case of problems related to the distribution or quality of the signal, which do not fall under the responsibility of Belgacom.

Belgacom is not responsible for signal deficiency or loss at broadcaster side, for instance in following events:

- for all channels : loss of play-out, corrupted contribution source, unannounced changes in broadcaster's feed definition/encoding/encryption, loss of power at broadcaster location;
- for international channels : uplink/downlink or terrestrial broadcaster's feed contribution problems, no decryption rights renewal due to broadcaster, unannounced broadcaster's encryption/feed changes.

Moreover, Customer recognises and accepts that Belgacom cannot be held liable in case of a temporary reduction in quality, a weak transmission or a temporary degradation of the transmitted signal.

If Belgacom is informed the signal is interrupted or suspended or if there is a significant degradation in the quality of sound and/or image of the channel, Belgacom shall take the measures which are within its control and which it deems reasonable and necessary to resolve the problem as soon as possible, provided the problem has its source within Belgacom's control and responsibility. Until the problem is solved, Belgacom shall insert a static or other type of image to inform the User of the issue.

### 8.3 Force Majeure

58. Neither Party will be liable for any delay or failure to fulfil its obligations under the Contract arising from any event beyond its reasonable control, such as for instance but without limitation: natural disasters (e.g. fire, flooding, earthquake), weather conditions (e.g. heavy rain, thunderstorms, snow, sun interference), strikes or intervention by a third party who does not act under the responsibility of that Party (e.g. looting, rioting, sabotage, unauthorised handling of Belgacom equipments or cabling by broadcasters at broadcaster location), all such events being hereafter referred to as "Force Majeure".
59. The Party claiming Force Majeure shall as soon as possible send to the other Party a Notice of the Force Majeure. Such Notice shall contain adequate evidence of the occurrence and extent of the Force Majeure, as well as an estimate of the expected duration of the Force Majeure. As soon as practicable after receipt of such Notice, the Parties shall consult with each other in order to find an equitable solution to the problems and difficulties caused by the Force Majeure.
60. The Party claiming Force Majeure shall use all reasonable endeavours to minimise the consequences of such Force Majeure, and to ensure, in as far as reasonably possible, the continuity of the services provided under the Contract and shall perform those of its obligations not affected by a Force Majeure. To the extent that a Party is prevented as a result of Force Majeure from providing one or several of the services or facilities to be provided under the Contract, the other Party shall be released to the equivalent extent from its obligations to make payment for such services or facilities or complying with its obligations in relation thereto.
61. Upon cessation of the effects of the Force Majeure, the Party initially affected by such Force Majeure shall promptly notify the other Party of such cessation.

### 8.4 Accidents at work and Safety Rules

62. Each Party hereby undertakes to provide insurance cover against accidents at work for its own employees in conformity with the applicable legal requirements. Each Party hereby renounces any possible claim against the other Party, and undertakes to procure that its insurer shall not pursue against the other Party, or against any third party for whose acts or omissions the other Party may be responsible, any claim relating to accidents at work.



63. Each Party shall comply with safety practices and procedures reasonably applicable when entering the premises and installations of the other Party in order to carry out work. Each Party undertakes to ensure that its personnel or its subcontractor personnel, while upon the premises and installations of the other Party, will respect any internal rules and codes of conduct therein applicable, provided that such rules and/or codes shall have been made available to them in advance. Without prejudice to the provisions of the chapter relating to Liability, each Party shall indemnify and hold harmless the other Party for any and all damages, costs or expenses incurred as a result of any act or omission of a Party's personnel or a Party's subcontractor personnel while upon the premises and installations of the other Party.

## 9 Operational Matters and Network Management

64. The Wholesale Multicast Services provided under the Contract shall be implemented and provided by the Parties in accordance with the technical specifications set forth in the Annex 2 “Technical Specifications” and the operational rules and procedures contained in the Annex 3 “Planning and Operations”.
65. Both Parties shall cooperate to install and maintain reliable services. Both Parties shall exchange appropriate information as provided in the Annex 3 “Planning and Operations” (including in particular, maintenance contact number, networks information, information required to comply with law enforcement and other security agencies of the government and such other information shall mutually agree) to achieve this desired reliability.
66. Each Party shall apply sound network management principles by invoking network management controls to ease the operation of their respective systems and to alleviate or to prevent congestion. In particular, Belgacom will control that the total volume of Dedicated Multicast Streams injected by the Customer in the Belgacom network does not exceed the limitations set forth in Annex 2.
67. The Parties shall ensure that the Essential Requirements, as defined and applicable under the regulatory framework, are adequately and sufficiently protected, in as far as the establishment, maintenance and operation of the Services offered under the Contract are concerned.
68. It is a condition for the provision by Belgacom of the Wholesale Multicast Services under the MULTICAST Offer that Customer’s Request is not detrimental to the operation of the Belgacom network and equipments (including the Belgacom IPTV Platform) and telecommunications services (including Belgacom TV services) or to their integrity or interoperability, and that the protection of service and internal data, network equipment, software and stored data, including personal data, confidential information and privacy can be sustained.
69. The conditions for and restrictions on use applying at any time appear from the Annex 2 “Technical specifications”.
70. Belgacom shall further be entitled to cause interruptions, disturbances or modifications of Belgacom’s network, equipments (including the Belgacom IPTV Platform) and Wholesale Multicast Services to the detriment of the supply of the Services under the Contract in connection with measures that are deemed necessary for technical, maintenance, development and operating reasons taking into account the balance of the interests of both Parties or, that are ordered by the regulatory authorities. Belgacom shall give in good faith Customer the longest possible notice of interruptions, disturbances and modifications, by any means it deems appropriate (e.g. via electronic communication) and state the reason for them.

## 10 Amendments and Revisions

### 10.1 General Principles

71. Except as otherwise provided in the MULTICAST Offer, any agreement departing from the Contract or its Annexes shall only be valid if duly agreed upon in writing by the respective representatives of the Parties.

## 11 Termination and Suspension

72. Customer has the right to terminate one or more Contracts as provided in the MULTICAST Offer. Belgacom has the right to terminate one or more Contracts in order to preserve Belgacom's network integrity and security, and for other particular reasons as listed below.
73. Without prejudice to the above, the Wholesale Multicast Services and related Contract(s) are automatically terminated when the necessary, underlying WBA VDSL2 services are cancelled for any reason.
74. A Multicast Contract shall automatically be terminated without prior notice to Customer upon the activation by Belgacom of another service (broadband service, possibly in combination with a TV solution) on the same line based on the valid migration request of either Belgacom retail or another Customer. Belgacom will further inform Customer of the new request without revealing the identity of the latter.
75. Belgacom will have the right to terminate the activation of the multicast functionality on the WBA VDSL2 line of each User when the Customer cancels the activation of the minimum set of Shared TV channels (see Main body, "Start-up Pack").
76. Belgacom will have the right to suspend or terminate access for the Customer and his Users to a particular Shared TV channel, at the written request of the content provider concerned. Belgacom will inform Customer as soon as possible of the cause of such suspension/termination.
77. Belgacom will have the right to stop the distribution of a signal of a specific Shared TV channel for its retail services, in which event the signal shall also be terminated for the Customer. In conformity with article 24 above, Belgacom will inform the Customer, who had access to this signal, with at least 2 months prior written notice of its termination.
78. The Customer is required to terminate the Contract related to the access to a particular Shared TV signal, as soon as his authorisations/intellectual property rights related to the content concerned have expired.
79. In the event Customer uses or allows the use of Services provided under the Contract in an illegal manner or for illegal purposes (such as for instance but without limitation: violation of intellectual property rights of third parties), or if Customer by its action or omission causes, or could reasonably be expected to cause a damage to the working or the security of the Belgacom network and equipments (including Belgacom IPTV platform), and Customer fails to take appropriate measures in order to remedy to the situation within a period of fifteen (15) days from the receipt of a Notice of Suspension sent by Belgacom, Belgacom will have the right to suspend the provision of some or all of the Wholesale Multicast Services. Notwithstanding the foregoing, Belgacom will have the right to take proactive actions prior to sending the above mentioned Notice in urgent cases where actions of Customer disturb the quality of the Shared TV signal and/or the stability of the Belgacom IPTV platform. In that case, Belgacom will inform the parties involved about the actions taken at the latest 24 hours after the suspension.
80. If the Customer uses or allows the use of Services provided under the Contract in a manner not corresponding to the Technical Specifications set forth in the Annex 2 "Technical Specifications", and Customer fails to take appropriate measures in order to remedy to the situation within a period of fifteen (15) days from the receipt of a Notice sent by Belgacom, Belgacom reserves the right to suspend all or some of the Services.
81. Belgacom will have the right to suspend or terminate Wholesale Multicast Services in the event that it is requested to do so by an order of a court or a competent authority. Belgacom will inform Customer as soon as possible of the cause of such suspension/termination.

82. Without prejudice to article 31, in the event that Customer fails to pay an outstanding invoice (invoice, pre-invoice or final invoice) for any amount due under the MULTICAST Offer, Belgacom shall be entitled, after having duly informed the BIPT,
- to suspend all Wholesale Multicast Services (entirely or partially, including suspension of any SLA obligations and refusal of any new Order) without further notice if the total amount due has not been paid within a period of fifteen (15) days following written Notice;
  - to terminate all Wholesale Multicast Services without further notice if the default is not cured within a period of 30 days following the same Notice.
83. Article 82 does not apply to amounts duly disputed by the Customer in writing, before the Due Date, including a clear summary of the grounds for the Dispute and the position of the Customer as to this dispute.
84. In the event that Customer fails to provide, renew, adapt or reconstitute the financial guarantee as provided in the chapter on Financial Guarantee here above, Belgacom shall be entitled, after having duly informed the BIPT,
- to suspend all Wholesale Multicast Services (entirely or partially, including suspension of any SLA obligations and refusal of any new Order) without further notice if the default is not cured within a period of 15 days following written Notice;
  - to terminate all Wholesale Multicast Services without further notice if the default is not cured within a period of 30 days following the same Notice.
85. The provisions of this chapter on suspension of the Services and termination of the Contract(s) are without prejudice to any other right or claim for compensation to which the non-defaulting Party may be entitled to in the event of suspension of one or more Services or termination of one or more Contracts, whatever is the case.
86. In the event of suspension or termination of one or more Services, Customer will be responsible to inform the relevant Users of the consequences of the suspension or termination of the Contract(s) in a neutral manner.
87. The Contract(s) are concluded on condition subsequent of termination in the event that either Party is declared bankrupt, ceases its business activities or enters into liquidation. In such event, the other Party may terminate all the Wholesale Multicast Services, without any further legal or other procedures, by sending notice of termination with immediate effect to the other Party.
88. In the case of termination of the Services for any reason, Belgacom shall be entitled to payment for all Services performed prior to such termination in accordance with the conditions that were applicable between the Parties at the time of termination.
89. The provisions of the Contract which by their nature are determined to survive the termination of the Contract (including, in particular but without limitation, the provisions on Confidentiality and Applicable Law and Jurisdiction) shall remain in full force and effect after the termination.

## 12 Confidentiality

### 12.1 Confidential Information

90. For the purpose of this Chapter, the term “Confidential Information” shall mean:
- information communicated by one Party (or from any of its Associated Companies) (the “Disclosing Party”) to the other Party (or to its employees and advisors) (the “Receiving Party”), or obtained by the Receiving Party in connection with the performance of the Services, provided that such information is, at the time of its disclosure, reasonably designated "confidential" or with an equivalent term. If such information was disclosed orally, it shall constitute Confidential Information provided that the Disclosing Party informs the other Party at the time of such disclosure, that such information is confidential and that (i) a written notice containing a summary of the information disclosed orally and mentioning that such information is confidential, is issued by the Disclosing Party to the other within five Working Days from the date of disclosure, or (ii) such disclosure is recorded in minutes of a meeting that are designated, labelled or marked "confidential" or designated, labelled or marked with an equivalent term.
  - Shall in any event be considered as Confidential Information, any information regarding the usage (new adding or termination) of TV channels by any Party before its commercial launch or communication to the public.
91. For purposes of these General Terms and Conditions, "Confidential Information" does not include:
- information that is properly and lawfully in the public domain otherwise than by breach of the Contract or any other obligation of confidence;
  - information that was disclosed by a third party to the Receiving Party without restriction on disclosure or use, unless the Receiving Party knew or should reasonably have known that this information was acquired unlawfully or by a breach of contract or fiduciary relationship.
92. Except as specified in writing, by the Disclosing Party at the time of disclosure, Confidential Information shall continue to be deemed as such until the end of a period of three (3) years after its initial communication under the Contract.

### 12.2 Non-Disclosure

93. The Receiving Party shall refrain from disclosing the Confidential Information to any third party and shall use the Confidential Information only for the performance of the Services offered in accordance with the Contract. In addition, the Receiving Party shall take any reasonable measures to ensure the confidentiality of this information. In any event, the Receiving Party shall use efforts at least commensurate with those that such Party uses for protecting the confidentiality of its own Confidential Information.
94. Notwithstanding the foregoing and without prejudice to the provisions regarding the Disclosure to Personnel, Advisors, Suppliers or Resellers here-under, either Party shall be allowed to disclose the Confidential Information to third parties provided it has obtained the prior written consent of the other Party. Such written consent will be given case-by-case upon a discretionary basis. Such written consent shall only be valid and enforceable for the specific information listed therein. The written consent to disclose Confidential Information shall identify the third party or parties to which the information can be disclosed and shall set forth the terms and conditions to which such disclosure is subject.
95. The Disclosing Party shall remain free to disclose to any third party Confidential Information disclosed to the Receiving Party.

## 12.3 Disclosure to Personnel, Advisors, Suppliers or Resellers

96. A Receiving Party shall disclose the Confidential Information received from the other only to its directors, employees, suppliers, agents, advisors, contractors, sub-contractors, or resellers who have a need to know such information. Such Party shall ensure that such directors, employees, suppliers, agents, advisors, contractors, sub-contractors or resellers are bound by the obligations of confidentiality in respect of the Confidential Information, which is at least equivalent to the confidentiality obligation set forth in the Contract.
97. Notwithstanding anything to the contrary in the foregoing provisions, the Receiving Party shall not disclose or use the Confidential Information, with the aim of providing commercial advantage to business divisions of the Receiving Party, or business divisions of the Receiving Party's Associated Companies, which are engaged in activities competing with the other Party.
98. Each Party shall be liable under the limitations provided in the Chapter relating to Liability here-above, for any unauthorized disclosure or use of the Confidential Information by its directors, employees, suppliers, agents, advisors, contractors or subcontractors. The Party responsible for an unauthorized disclosure or use of the Confidential Information shall, in any event, take any reasonable measures (including but not limited to court proceedings) to mitigate the damage resulting there-from.

## 12.4 Disclosure Required by Law

99. If the disclosure of Confidential Information to third parties is required by reason of legal, accounting or regulatory requirements beyond the control of the Receiving Party, the Receiving Party may disclose such information to the extent necessary to comply with such requirements. Without prejudice to the application of the foregoing, the Parties shall endeavour to ensure the confidential treatment of the Confidential Information by the third parties receiving such information as a result of such requirement.
100. Without limitation to the generality of the foregoing, either Party will have the right to disclose Confidential Information to the BIPT, whenever required by law, or deemed reasonably necessary in the context of any proceedings or discussions held in front or with the BIPT. If any such disclosure of Confidential Information is made, the Party communicating the information will ensure that the attention of the BIPT is properly drawn to the fact that the information is confidential and that the information needs to be kept confidential.

## 13 Dispute Resolution and Applicable Law

### 13.1 Dispute resolution procedure

101. The SPOC shall, on an ongoing basis, attempt to solve any dispute, controversy or claim between the Parties concerning the interpretation, application and implementation of the present General Terms and Conditions and/or the Contract and its Annexes (a “Dispute”) through discussions held in good faith.
102. In the event that the Parties have been unable to solve any Dispute, then upon Notice of either Party, each of the Parties will appoint a designated senior business executive (other than their respective SPOC) whose task it will be to meet for the purpose of endeavouring to resolve the Dispute. Each Party shall ensure that their respective designated executive has sufficient authority or decision-making power concerning the matter at stake. The designated executives will meet as often as the Parties reasonably deem necessary in order to gather and furnish to the other all information with respect to the matter in issue which the Parties believe to be appropriate in connection with its resolution. Such executives will discuss the Dispute and will negotiate in good faith in an effort to resolve the Dispute without the necessity of any formal proceeding relating thereto.
103. In the event the Parties fail to reach such a solution and/or settlement within fifteen (15) Working Days as from the receipt of the above Notice, they shall escalate the matter to a higher level within their respective organizations. Discussions at that level will be conducted as described in article 102. The Parties may, at any given escalation level, agree to extend the time limits described in this article and in article 102 when they consider it necessary in order to facilitate that an agreement be concluded on the subject-matter of the dispute.
104. Except in the cases of urgency, as determined in good faith by the Party calling the Dispute, and unless otherwise in these general Terms and Conditions, no formal proceedings for the resolution of a Dispute may be started until the earlier to occur of (a) a good faith conclusion by the designated executives that amicable resolution through continued negotiation of the matter in issue does not appear likely or (b) the Parties have failed to reach an agreement on the Dispute within 15 Working Days of the escalation of the Dispute as described in article 102.

### 13.2 Applicable Law and Jurisdiction

105. The MULTICAST Offer, its Annexes, and the Contract(s) shall be governed by Belgian law.
106. Without prejudice to article 104, any dispute concerning the validity or the interpretation of the MULTICAST Offer and the Contract(s), or the performance of the Wholesale Multicast Services, or of subsequent contracts derived here-from shall be finally submitted to the Courts of Brussels, Belgium. This provision is without prejudice to the right of each of the Parties to submit the dispute to the BIPT with a view to reach conciliation or to submit the dispute to the Competition Council.

## 14 Miscellaneous

### 14.1 General Principles

107. All the terms and conditions of this MULTICAST Offer, including its Annexes and/or Appendixes, are agreed upon by the Parties without prejudice to the rights and obligations that either Party may derive from the applicable provisions of the regulatory framework. The fact that either Party has agreed to any provision in this MULTICAST Offer will not be construed as a renunciation by such Party to invoke (i) any right that such Party may derive from any imperative provision of the applicable regulatory framework or (ii) any obligation that may be imposed to the other Party pursuant to any imperative provision of the applicable regulatory framework.
108. In the framework of the MULTICAST Offer, should a conflict arise between the Main Body, and any or several Annexes, attachment or appendix to an Annex, the Main Body shall prevail, except for (a) Annex 1 - General Terms and Conditions, which will prevail over the Main Body unless otherwise specifically stated, (b) when otherwise agreed by the Parties, in writing or (c) when otherwise specifically stated in the Main Body or Annex, Attachment or Appendix. Should a conflict arise between Annex 1 - General Terms and Conditions and another Annex, attachment or an appendix to said other Annex, the Annex 1 - General Terms and Conditions shall prevail unless otherwise specifically stated. Should a conflict arise between an Annex and an attachment or an appendix to this Annex, the Annex shall prevail unless otherwise agreed by the Parties, in writing or otherwise specifically stated.

### 14.2 Notices – Address for Invoicing

109. Unless stated otherwise in the MULTICAST Offer or its Annexes, any Notice under the Contract(s) will be sent to the respective SPOC of the Parties, in writing and by registered mail or by email (so called “Flash communication” sent by Belgacom to its Customers) to the addresses indicated in a formal confirmation letter signed between Parties. Belgacom shall send the invoices and credit notes by ordinary mail, via email or via CertiOne (see Annex 5 “Pricing and Billing”) to the invoicing address of the Customer indicated in the same confirmation letter.

### 14.3 No Assignment

110. Neither of the Parties is entitled to assign the Contract, in part or in its entirety, to any third party or to any other entity unless with the prior written approval of the other Party.
111. No approval will be required for an assignment of the Contract in case of transfer to a successor, to which a transfer has taken place of, at least, the Assigning Party’s activities covered by the Contract. In such a case, the assigning Party shall immediately give Notice to the other Party of any such assignment permitted to be made under the Contract without requesting the other Party’s consent.
112. Without prejudice to the foregoing, no assignment shall be valid unless the assignee agrees in writing to be bound by the provisions of the Contract and its Annexes.

## 14.4 Waiver

113. A failure by either Belgacom or Customer to insist on the performance of any term of the Contract or to exercise any right or privilege hereunder shall not be construed as a continuing or future waiver of such term, condition, right or privilege. No waiver shall be valid unless it is in writing and signed on behalf of the Party making the waiver.

## 14.5 Fraud

114. The Parties accept to cooperate to the best of their respective abilities in order to prevent and eliminate any kind of fraud which involves Services provided under the Contract. If any of the Parties suspects such kind of fraud, the Parties shall co-operate in order to identify the origin of the fraud and to use any appropriate means in order to eliminate and prevent such fraud as soon as possible. For the purposes of the application of the present provision, fraud shall mean any manipulation of a communications network, including by Customer connected to the network of one of the Parties, in order to obtain one or more telecommunication or IPTV services without paying the proper charge for it, or to support other criminal activities (including, in particular, wiretapping, eavesdropping and gathering secret numbers).
115. It is explicitly acknowledged by the Parties that any cooperation in the context of the present provision will need to be in due compliance with the entire regulatory framework.

## 14.6 Independent Parties – Approvals

116. Each Party shall be responsible for obtaining and keeping in effect all approvals from, and rights granted by, competent authorities, other operators, and any other persons that may be required in connection with the performance of its obligations under the Contract. Each Party shall reasonably cooperate with the other Party in obtaining and maintaining any required approvals and rights for which other Party is responsible.
117. Each of the Parties is and shall remain at all times an independent contractor. Neither Party is authorized and neither of the Parties nor their employees, agents, representatives or subcontractors shall at any time attempt to act or act on behalf of the other Party to bind the other Party in any manner whatsoever to any obligations. Neither Party nor its employees, agents or representatives shall engage in any acts which may lead any person to believe that such Party is an employee, agent or representative of the other Party. Nothing in the Contract shall be deemed to constitute a partnership between the Parties.

Wholesale Multicast

# Annex 2: Technical specifications

Created on: 06 March 2012

belgacom

together with





together  
with



# 1 Table of contents

<b>1</b>	<b>Table of contents .....</b>	<b>2</b>
<b>2</b>	<b>Abbreviations .....</b>	<b>3</b>
<b>3</b>	<b>Scope .....</b>	<b>5</b>
<b>4</b>	<b>End-to-end view .....</b>	<b>6</b>
<b>5</b>	<b>UNI.....</b>	<b>7</b>
<b>6</b>	<b>DSLAM Platform .....</b>	<b>8</b>
6.1	VLAN ID ALLOCATION.....	8
6.2	Multicast configuration .....	9
6.3	Multicast CAC (Connection Admission Control) on the first mile (DSL line).....	9
6.4	Customer's User configuration.....	10
<b>7</b>	<b>WBA transport in Belgacom Ethernet network .....</b>	<b>11</b>
7.1	Multicast ingestion by the Customer .....	12
7.2	Shared TV Channel interface .....	12
<b>8</b>	<b>MULTICAST CHANNELS .....</b>	<b>13</b>
8.1	MPEG 2 Transport Stream.....	13
8.2	IP encapsulation .....	14
8.3	Layer 2 encapsulation.....	14
8.4	VERIMATRIX ENCRYPTION .....	15
8.5	Verimatrix Components .....	15
8.5.1	VCAS™ for IPTV .....	15
8.5.2	Remote Stream Manager .....	15
8.6	VPN between the Customer and Belgacom Verimatrix Components .....	16

## 2 Abbreviations

	Description
CAC	Connection Acceptance Control
DHCP	Dynamic Host Configuration Protocol
DS	Downstream
GE	Gigabit Ethernet
IPoE	Internet Protocol over Ethernet
LACP	Link Aggregation Control Protocol
LAG	Link Aggregation
LAN	Local Access Network
LEX	Local Exchange
LTE	Line Termination Equipment
MTU	Maximum Transmission Unit
OAL	<u>O</u> LO (Ethernet) <u>A</u> ccess <u>L</u> ine
OLO	Other Licensed Operator
p-bit	Priority bit
PoP	Point of Presence
PPP	Point to Point Protocol
PPPoE	Point to Point Protocol over Ethernet
UNI	User Network Interface
US	Upstream
U2U	User to User (communication)
VDSL2	Very High Speed Digital Subscriber Line 2 (= Ethernet Based, while VDSL1 is ATM based)



together  
with



VLAN  WBA VDSL2	Virtual LAN.  Wholesale Broadband Access VDSL2. Here only the types of service: with shared VLAN is concerned, NOT “dedicated VLAN”.
-----------------------	--

### 3 Scope

1. The purpose of this document is:
  - To describe the technical specifications of the Multicast TV Services. Note that the description of the service is available in the Multicast TV Offer, Main Body.
  - To allow the Operator to setup a service based on this service from Belgacom, describing the interfaces in detail.
2. Multicast TV Services are based on the WBA VDSL2 offer. Only delta's and specific issues are repeated here further.
3. Prerequisite for a Customer willing to offer this service to his end-users in a specific LEX, is to have a WBA VDSL2 shared VLAN "p3" in this LEX.
4. The WBA VDSL2 "with dedicated VLAN" is not compatible with this service, because of the crossconnect type of connectivity in the VDSL2 DSLAM (ISAM), which cannot be combined with the bridged connectivity, required for this multicast service.

## 4 End-to-end view

5. The User, for whom the Customer has ordered Multicast TV Services, will have access to:
  - Multicast TV channels ingested by his operator in the Belgacom PIM Core network, in a specific way described further, together with other multicast (e.g. STB update) data . Belgacom will allocate to each Customer a dedicated Multicast Group IP address range for this purpose.
  - Shared TV Channels, shared between Belgacom and his operator.
6. Both flows are transported together in the Belgacom PIM Core network and the aggregation networks, up to the VLAN 40 of the WBA VDSL2 User for whom the Customer has ordered Multicast.
7. The TV related unicast to this User, eg Encryption keys, unicast Settop Box management, VOD, Unicast TV,..., shall be transported via the shared VLAN “p3” and will also be delivered via VLAN id 40 on the WBA VDSL2 User line.

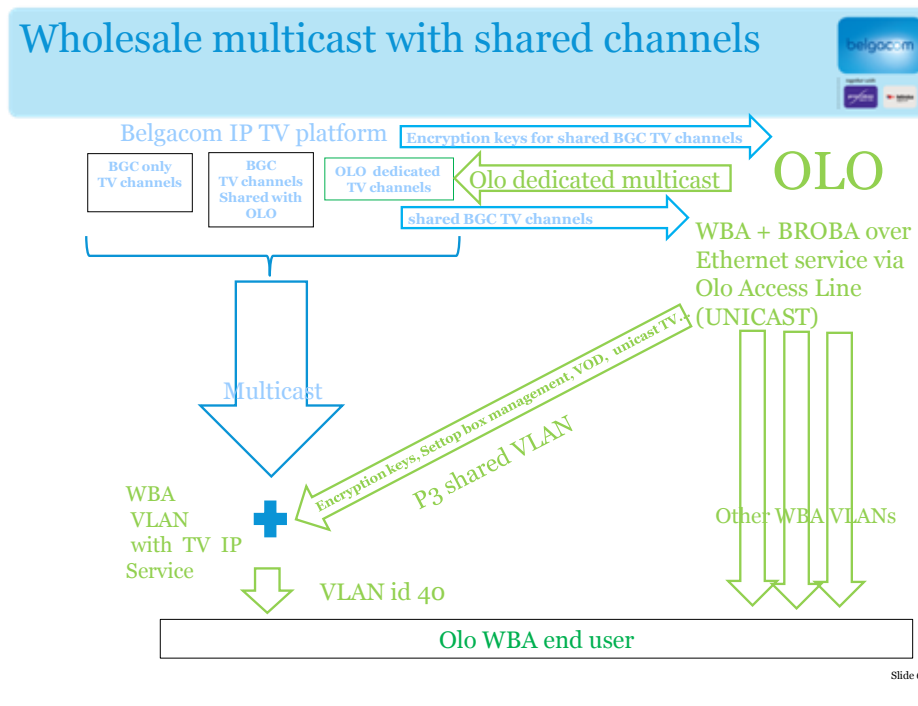

8. The Customer shall obtain encryption keys for the Shared TV channels, agreed with Belgacom and shall distribute them to his Users. These TV Channels are encrypted.

## 5 UNI

9. The WBA VDSL2 line profiles, according to Belgacom Deployment Rules (WBA VDSL2 Main Body - Section 4.13), are listed in the detailed IT protocol of deliverable 2 regarding VDSL2 OLO CPE for WBA.

## 6 DSLAM Platform

### 6.1 VLAN ID ALLOCATION

10. The DSLAM performs two major functions:

- The Customer's User VLAN (VLAN ID 40) is mapped to the Customer's unicast TV VLAN at the uplink with VLAN Translation
- Multiplexing of Customer's unicast TV VLAN and MC VLAN (uplink) to one VLAN (TV unicast/MC) at the subscriber port.

11. On UNI 4 VLANs are foreseen in the WBA VDSL2 Offer. Multicast will be offered on VLAN 40 (p-bit 3). The latter will be translated to the respective Customer NNI VLAN (p-3). VLAN 40 will be connected only to the "P3" shared VLAN. The VLAN 40 will contain P3 unicast and P4 Multicast. On NNI, Belgacom multicast VLAN will be used for multicast on WBA VDSL2 line.

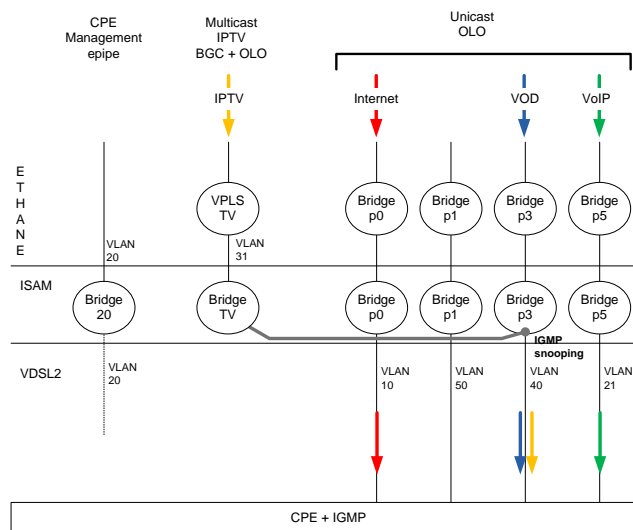

## 6.2 Multicast configuration

12. All channels (Belgacom Shared TV Channels and the Customer's dedicated multicast streams) are configured with ethernet BW in order to provide multicast CAC on DSL line.
13. Fast leave mechanism is enabled for a multicast stream so the stream is immediately stopped on reception of the leave message if no other users on that line have joined the same stream.
14. IGMP system parameters
  - IGMP proxy. The source IP@ of the IGMP proxy function: 195.13.31.34
  - IGMPv3 with backward compatibility towards IGMPv2.
  - IGMP default system parameters

Parameter	Value
Robustness	2
Query interval	125s
Query maximum response time	10s

## 6.3 Multicast CAC (Connection Admission Control) on the first mile (DSL line)

15. Each multicast group is configured at DSLAM level with their respective bandwidth. The latter is expressed as Ethernet BW and corresponds to the peak rate.
16. Upon every IGMP join request, the bandwidth of the requested multicast stream is checked with the available bandwidth on the DSL line. If the available BW is lower than the BW of the requested multicast stream and the stream would still be forwarded towards the User, all services of the User would be impacted.
17. The available multicast bandwidth is derived from the Actual Line Rate (ALR) and the EFM overhead. The Ethernet EFM overhead factor is used to calculate EFM bandwidth required by streams for which bandwidth parameters are specified as Ethernet bandwidth. A typical overhead of 3% for EFM encapsulation is configured at system level.
18. Formula applied in order to calculate the available bandwidth (BW) on DSL line:

$$\text{Available BW} = (\text{Actual Line Rate (ALR)} * 97\%) - (\text{sum of configured bandwidth for the multicast groups currently received})$$

19. On the line there is no portion reserved for voice and data. Only multicast traffic is controlled by the CAC functionality.

20. Formula applied in order to allow a connection (join):

Configured bandwidth of new stream  $\leq$  available BW

21. The CAC on DSL is enabled at system level.

## 6.4 Customer's User configuration

22. IGMP control channel on VLAN 40

23. Dsl ctrl pkt policer: Policer for control traffic like IGMP (/DHCP/PADx messages/802.1x...) aligned with Belgacom implementation (~ 16 messages/s).

24. BW CAC on DSL line: CAC profiles are used primarily for multicast video admission control.

25. Limitation of the maximum number of multicast channels per DSL line aligned with BELGACOM implementation. At present limitation is set to 10 multicast groups.

## 7 WBA transport in Belgacom Ethernet network

26. Users of a Customer are only allowed in a specific LEX, if the Customer has an active “P3” (not p3bis”) shared VLAN to this LEX, otherwise no VLAN 40 VLANs, neither TV, can be configured in this LEX for his Users.
27. The WBA p3 “shared Vlan” is configured as defined in the WBA VDSL2 Offer.
28. The dimensioning of the “p3” VLAN is under responsibility of the Customer. Note that this “p3” shared VLAN may also transport BROBA over Ethernet traffic designated to his rt-VBR BROBA over Ethernet customers. It is not supporting multicast.
29. All multicast, Belgacom Shared TV Channels and the Customer’s dedicated multicast streams, is transported together with in the Belgacom “PIM Core” network, offering national coverage, towards all Service Pops on the aggregation rings.
30. IGMP from a specific VLAN (31 on figure) at ISAM NT is requesting the multicast (Belgacom Shared TV Channels Customer’s dedicated multicast streams) in the aggregation rings up to the Service pop.
31. The figure shows the multicast of a specific Multicast Group, ingested by a Customer.

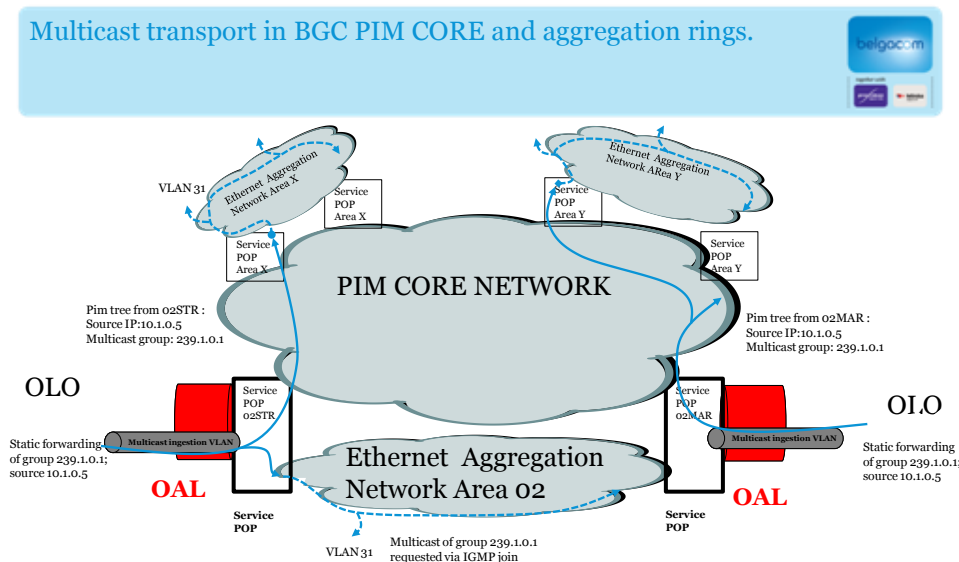

## 7.1 Multicast ingestion by the Customer

32. The Customer may (as an option) ingest a limited amount of multicast in the Belgacom network, which will be transported and delivered via WBA VDSL2 access, together with Belgacom TV to his TV enabled User.
33. Ingestion Bandwidth will be limited to the Ordered Dedicated Capacity for all multicast ingested by the Customer.
34. The Customer can ingest multicast groups contained in the /27 multicast address allocated to him by Belgacom. Other traffic and Unicast flows will be blocked at ingress of ingestion point in the Belgacom network. For sake of stability of the Belgacom PIM core network, no PIM protocol is allowed on Ingestion point, just static ingestion is allowed.
35. The Customer shall provide the following information for the configuration at DSLAM level of its dedicated multicast streams:
  - Multicast group
  - Name multicast channel
  - Ethernet BW
36. The Customer shall use one owned public unicast IP address /x (x to be decided by the Customer) as source for his multicast. Belgacom will route this in his network for both ingestion points.
37. VLAN 106 on an OAL in LEX 02STR and / or 02MAR shall be used for ingestion. The Customer can decide to use these OALs (other VLAN ids) for other regulated services, under his responsibility. The Ethernet Qos of all multicast is p4. Two injection points are meant for redundancy and shall transport exactly the same flows, because some Customer's Users will get multicast originating from a PIM tree at one ingestion point and other Customer's Users from another ingestion point, which is decided by PIM routing. A link protocol will indicate to the routing in the Belgacom network if the ingestion point is alive or not. If link protocol at one ingestion point fails, then it will release all its PIM trees and these will be rebuild from the PIM tree on the other ingestion point, if this is still up.

## 7.2 Shared TV Channel interface

38. The Customer can (as an option) receive the encrypted shared TV Channels which he is entitled to deliver to his Users:
  - VLAN 107 on an OAL in LEX 02STR and / or 02MAR shall be used for this flow. The Customer can decide to use these OALs (other VLAN ids) for other regulated services, eg the multicast ingestion , under his responsibility. The Ethernet Qos of all multicast is p4.
  - The data flow is obtained by a static IGMP configuration of the multicast groups, to which the Customer is entitled, at Belgacom side. No protocol is allowed (eg no IGMP). All ingress traffic in Belgacom network will be blocked.

## 8 MULTICAST CHANNELS

39. As part of this Wholesale offer, Belgacom provides Shared TV Channels.

### 8.1 MPEG 2 Transport Stream

40. Each channel is conveyed in a separate MPEG-2 transport stream which can contain video, audio and teletext.

41. Normative references:

- MPEG 2 Transport Stream: ISO/IEC standard 13818-1
- MPEG 2 measurement guidelines: ETSI EN 101290
- Teletext: Teletext based on ETSI EN300294,  
ETSI EN 300472 & ETSI EN 300706 for Enhanced Teletext
- WSS carriage : ETSI EN 301775
- Mapping of audio & video in MPEG2 system: ETSI EN 101154
- Mapping of AC-3 : ETSI EN 300468

42. The following table shows the codecs used for video and audio, at the time of writing:

Radio channels	Audio: Musicam (MP1L2) stereo
SD TV	Video: H.264 MP@L3 Audio: Musicam (MP1L2) stereo
HD TV	Video: H.264 HP@L4 Audio: AAC (MP2) stereo; or Dolby Digital
3D TV	Video: H.264 HP@L4 Audio: AAC (MP2) stereo



together  
with



Note: H.264 is referring to ISO/IEC 14496.10

43. Belgacom reserves the right to change codecs. The process to be followed in case of a codec change is specified in Annex 3 – Planning and Operations.
44. Bitrates at the MPEG 2 TS level are:
- Standard Definition: 2,5 Mb/s
  - High-Definition: 6,2 Mb/s
  - 3D: 8,6 Mb/s
  - Radio channel: 0,28 Mb/s
45. Belgacom reserves the right to change bitrates. The Customer will be notified of any bitrate change at least three months before the modification is brought live for Belgacom retail Users

## 8.2 IP encapsulation

46. The MPEG-2 transport stream is encapsulated:
- for the TV channels: in RTP/UDP/IP.
  - for the radio channels: in UDP/IP
47. Normative references:
- RTP: A Transport Protocol for Real-Time Applications (RFC 1889)
  - RTP Payload Format for MPEG1/MPEG2 Video (RFC 2250)
48. Each channel is mapped into a specific multicast IP group. The multicast addresses are taken from the administratively scoped IPv4 multicast space, as defined in RFC 2365; and more specifically from:
- The IPv4 Organization Local Scope -- 239.192.0.0/14
  - The IPv4 Local Scope -- 239.255.0.0/16

## 8.3 Layer 2 encapsulation

49. On the Access Line, the IP packets are encapsulated in the appropriate layer 2 protocols, as described in the WBA VDSL2 offer.

## 8.4 VERIMATRIX ENCRYPTION

50. The payload of the MPEG 2 transport packets is encrypted by means of the Verimatrix “Video Content Authority System (VCAS™) for IPTV” solution.
51. The provider of this solution is:

Verimatrix Inc.

6825 Flanders Drive

San Diego, CA 92121

USA

[www.verimatrix.com](http://www.verimatrix.com)

## 8.5 Verimatrix Components

52. If the Customer wishes to use the Wholesale service with multicast needs to deploy a Verimatrix “Video Content Authority System (VCAS™) for IPTV” system with a Remote Stream Manager component.

### 8.5.1 VCAS™ for IPTV

53. The VCAS™ for IPTV performs stream formatting and real-time encryption of multicast IP transport streams containing compressed video in an MPEG-2 Transport Stream format. The VCAS™ solution also generates and distributes the necessary encryption keys to client devices such as Set Top Boxes.
54. In the context of this offer, the Customer VCAS™ will be used to store and distribute the encryption keys for the Shared TV channels. For the Customer dedicated channels, the Customer is free to use the conditional access technology of his choice.

### 8.5.2 Remote Stream Manager

55. Verimatrix Remote Stream Manager (RSM) is an optional component within the Video Content Authority System (VCAS™). RSM optimizes IPTV wholesale/retail configurations by enabling seamless end-to-end encryption of broadcast channels combined with secure, locally-originated content.

56. The Verimatrix RSM will periodically fetch the decryption keys for the shared channels that the Customer is entitled to from the Belgacom VCAS servers via a virtual private network. This enables the Customer to store these keys for further distribution to his own end customers.

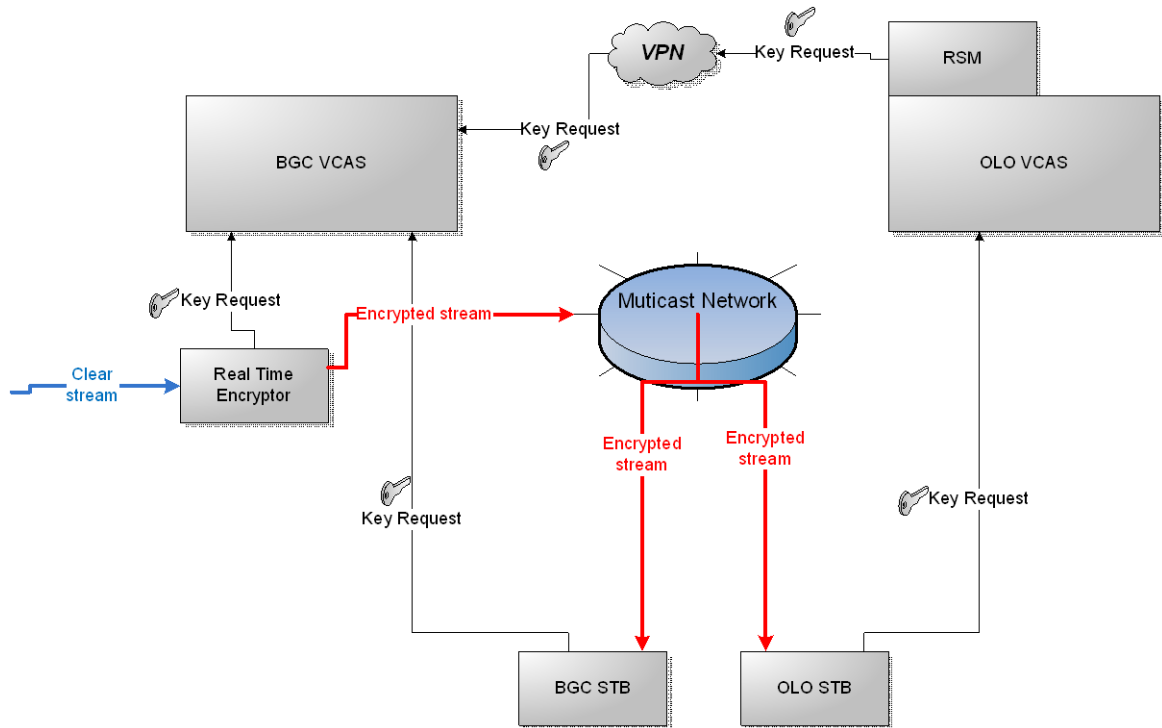

57. It is the responsibility of the Customer to securely store the encryption keys for further use.

## 8.6 VPN between the Customer and Belgacom Verimatrix Components

58. The virtual private network that connects the Customer RSM component to the Belgacom VCAS servers is implemented via VLANs on one or two (for redundancy) OALs. Belgacom has two redundant accesses to his VCAS™ platform, one in o2EVE (Brussels Area) and one in 15MEC (Antwerp Area).

- VLAN id 104 : to o2EVE
- VLAN id 105 : to 15MEC

◆◆◆◆◆ End of document ◆◆◆◆◆

Wholesale Multicast

# Annex 3: Planning & Operations

Created on: 06 March 2012

belgacom

together with





together  
with



# 1 Table of contents

<b>1</b>	<b>Table of contents</b> .....	<b>2</b>
<b>2</b>	<b>Introduction</b> .....	<b>5</b>
<b>3</b>	<b>Acronyms</b> .....	<b>6</b>
<b>4</b>	<b>Exchange of information</b> .....	<b>7</b>
4.1	Single Point Of contact .....	7
4.2	Preliminary Exchange of Information for the initial setting up.....	7
4.3	Implementation Committee .....	7
<b>5</b>	<b>Ordering Encryption Key Interface</b> .....	<b>8</b>
5.1	General.....	8
5.2	Ordering procedure.....	8
<b>6</b>	<b>Ordering Shared TV Channel</b> .....	<b>10</b>
6.1	Shared TV Channel Activation.....	10
6.1.1	General.....	10
6.1.2	Prerequisites .....	10
6.1.3	Ordering procedure .....	11
6.2	Shared TV Channel Deactivation.....	11
6.2.1	General.....	11
6.2.2	Prerequisites .....	12
6.2.3	Ordering procedure .....	12
6.3	Shared TV Channel Management .....	12
6.3.1	Shared TV Channel Stop – Specific Case.....	12
6.3.2	Share Channel Stop – General Case .....	12
<b>7</b>	<b>Ordering Dedicated Capacity</b> .....	<b>14</b>
7.1	Dedicated Capacity Initial Set-up .....	14
7.2	Ordering procedure of Dedicated Capacity Initial Set-up .....	15



together  
with



7.3	Dedicated Capacity Increase .....	15
7.4	Dedicated Capacity Decrease.....	16
7.5	Modification of Dedicated Stream Bandwidth configuration .....	16
<b>8</b>	<b>Implementation Information .....</b>	<b>18</b>
<b>9</b>	<b>Ordering Multicast functionality on a specific User line (WBA VDSL2) .....</b>	<b>19</b>
9.1	General.....	19
9.2	Ordering via XML.....	19
9.2.1	Generals .....	19
9.2.2	Definitions .....	20
9.2.3	Escalations.....	21
<b>10</b>	<b>Forecasting of orders.....</b>	<b>22</b>
10.1.1	General Principles .....	22
10.1.2	Processing of Forecasts .....	22
10.1.3	Underrun .....	23
10.1.4	Overrun.....	23
<b>11</b>	<b>Fault Reporting and Repair .....</b>	<b>24</b>
11.1	General Process.....	24
11.2	Points of Entry for Complaint .....	24
11.3	Fault Reporting .....	24
11.4	Customer's liabilities in connection with fault reporting.....	25
11.5	Belgacom's liability in connection with fault reporting .....	25
11.6	Special conditions in connection with Repair .....	26
11.7	Repair Request and Feedback .....	26
11.7.1	Multicast on an User Line .....	26
11.7.2	Shared TV Channels .....	26
11.7.3	Dedicated Capacity .....	27
11.8	Wrongful repair request .....	27
<b>12</b>	<b>Phases in the provisioning of the Multicast Services.....</b>	<b>28</b>
12.1	Friendly User Testing Phase.....	28



together  
with



12.2 Full Commercial Phase.....	28
<b>13 Shared Channel Change Management .....</b>	<b>29</b>
13.1 General.....	29
<b>14 Glossary .....</b>	<b>31</b>
<b>Appendix A: Statement of requirements, template for the Customer .....</b>	<b>32</b>
General .32	
Basic information .....	32
Registered name and address of Customer .....	32
Confidentiality agreement .....	32
Key Contacts list .....	33
Key project dates .....	33
Wholesale Multicast Products and Services Customer wishes to obtain from Belgacom .....	33

## 2 Introduction

1. This annex describes the Planning and Operations principles, related to the provisioning and repair of the Wholesale Multicast Services.
2. Both parties will use at any time their best efforts to ensure an adequate level of service provisioning both between the Parties and towards the Users concerned.
3. In the event that difficulties or problems arise in respect of Planning and Operations, the Parties will perform all necessary co-operation and consultation with a view to developing appropriate and workable solutions.
4. All relevant technical documentation and order forms if any can be retrieved at the secured part of the website for this offer.

### 3 Acronyms

<b>ACK</b>	Acknowledged
<b>CID</b>	Circuit Identifier
<b>CSD</b>	Customer Support Desk
<b>CWS</b>	Carrier and Wholesale Services
<b>FUT</b>	Friendly User Testing
<b>NACK</b>	Not Acknowledged
<b>REM</b>	Retailer Entitlement Manager
<b>RSM</b>	Remote Stream Manager
<b>SOR</b>	Statement Of Requirements
<b>SPOC</b>	Single Point Of Contact
<b>VDSL<sub>2</sub></b>	Very High Speed Digital Subscriber Line 2
<b>VLAN</b>	Virtual Local Area Network.
<b>VCAS</b>	Verimatrix Content Authority Manager

## 4 Exchange of information

5. This chapter includes some communication guidelines in order to ensure a good interchange of information and to define an effective communication channel that focuses on both improving the comprehension and execution of the processes.

### 4.1 Single Point Of contact

6. Both Parties will appoint a member of its staff as Single Point Of Contact for Wholesale Multicast. This person, referred to as "SPOC", will be in charge of all matters regarding the day-to-day management of the performance of this offer. In particular, all firm orders must be submitted by registered mail to the SPOC of Belgacom, unless noticed otherwise.

### 4.2 Preliminary Exchange of Information for the initial setting up

7. Without prejudice to what is stated above, it is recommended that the Customer provides a Statement Of Requirements (SOR) to Belgacom as early as possible in any discussions between The Customer and Belgacom. The SOR is sent by registered mail to the SPOC of Belgacom. After the receipt of the SOR, Belgacom shall notify to the Customer its observations, if any, concerning the SOR. In particular, when appropriate, Belgacom may request additional information to complete the information contained in the SOR. For more information on the SOR, reference is made to Appendix A of this document.

### 4.3 Implementation Committee

8. The Implementation Committee is a meeting between both parties to supervise, discuss and examine at a general level technical and operational application of this offer, in particular, the implementation of the respective obligations of the Parties, as described in this offer.
9. The Implementation Committee will meet at least on a quarterly basis. Each Party will be entitled to call additional meetings within reasonable notice, as may be necessary. Each Party will be represented at the Implementation Committee by its SPOC accompanied by any staff as deemed necessary by the relevant Party.
10. In addition to the Implementation Committee, the Parties will be allowed to request for the set-up of any other bilateral working group in charge of discussing and agreeing on any technical or operational issues, including more specialized members on the specific topic.

## 5 Ordering Encryption Key Interface

### 5.1 General

11. Before the Customer can order the Encryption key interface an OLO Access Line needs to be in Service in one of the following Service PoP's:
  - o2STR
  - o2MAR
  - o3CEN
  - o3BKC
12. The Encryption key interface set-up is mandatory prior to the ordering of a Shared TV channel.
13. The ordering of the Encryption Key Interface shall be done through the use of a specific template provided in [Appendix D](#) of this document. In case data is missing or is not correct, the template will be rejected. In the latter case, Belgacom will indicate the reasons of rejection on the template. All firm orders will be submitted by email to the SPOC of Belgacom for Wholesale Multicast.
14. Before a Customer can order a Shared TV channel an Encryption Key Interface is required.
15. The Encryption Key Interface is made up of:
  - A specific VLAN configured on an OAL. The OAL on which the VLAN is configured is left at Customer discretion but must end up on one of the following Service PoP: o2MAR, o2STR, o2CEN or o3BKC. Further information regarding those Service PoP's is available in the WBA VDSL2 offer – Main Body.
  - 
  - Network configuration enabling the connection of the service PoP's selected by the Customer to the Belgacom VCAS platforms located in GAM and Mechelen.
  - The creation of the Customer instance in the Belgacom VCAS REM module.
16. The Encryption Key Interface is used for enabling the provisioning of Shared TV channel encryption keys from Belgacom to the Customer infrastructure.

### 5.2 Ordering procedure

17. The Customer can order its Encryption Key Interface through a firm order. A firm order consists of the requested Encryption Key Interface. Together with the firm order, the Customer includes the date when he wants the Encryption Key Interface to be ready.
18. The Customer is notified that in very exceptional situations, significant delays may be experienced :
  - In case of periods of large demands that could not be foreseen,
  - In an emergency situation (i.e., exceptional cases of *force majeure*),



19. When the installation of the Encryption Key Interface is done, Belgacom will confirm it to the Customer.
20. Once confirmed, the installation shall be subject to the validation of the Customer
21. The Encryption Key Interface phase isto be performed by the Customer. The Interface ordering will be considered as complete once the Customer has accepted the interface implementation through a firm confirmation
22. Belgacom shall provide the Customer with the necessary support during the validation phase.

## 6 Ordering Shared TV Channel

### 6.1 Shared TV Channel Activation

#### 6.1.1 General

23. Belgacom will offer the Customer access to a pool of Shared TV channels.
24. Belgacom Shared TV Channels are encrypted by Belgacom and made available in Belgacom network.
25. The access is defined per channel and the Customer can decide which channel from the Belgacom Shared TV Channel pool it wants to activate.
26. The activation of a given Shared TV channel upon Customer request consists in making the corresponding encryption key available for the Customer.
27. Once a Shared TV channel is activated upon Customer request the Customer is responsible for fetching the encryption key as described in Annex 2 – Technical Specifications.
28. The Customer is responsible for all other actions required to make its end-user capable of decrypting an activated Shared TV Channel made available by Belgacom in Belgacom network.
29. Firm order of Shared TV Channel activation shall be done through the use of an order form available on the Belgacom secured website. In case data is missing or is not correct, the template will be rejected. In the latter case, Belgacom will indicate the reasons of rejection on the template. All firm orders will be submitted by email to the SPOC of Belgacom for Wholesale Multicast.
30. The request must be sent via email by the Customer to Belgacom single point of contact in charge of Belgacom Wholesale Multicast Services.
31. The order must be accompanied with a firm confirmation that the Customer is granted by the Channel owner to multicast the TV signal towards its Users.
32. The Customer can group in a single order the activation of several Shared TV Channels.
33. If multiple Shared TV Channels are ordered in the same request the Customer shall make sure that content rights confirmation for each channel is provided.

#### 6.1.2 Prerequisites

34. An Encryption Key Interface has to be implemented between the Belgacom VCAS REM and the Customer VCAS RSM.
35. The Customer has been granted by the Right holders to provide its Users with the corresponding content.

### 6.1.3 Ordering procedure

36. The Customer can order a Shared TV Channel through a firm order. A firm order consists of the requested Shared TV Channel with its associated parameters (the channel name, the channel id, the implementation date,...).
37. The Customer shall provide Belgacom with the confirmation that the Right holder has granted the Customer that it can provide its Users with the corresponding content. That confirmation shall be done through the signature of the legal document provided which will be available on the Belgacom secured website.
38. The Customer is notified that in very exceptional situations, significant delays may be experienced:
  - In case of periods of large demands that could not be foreseen,
  - In an emergency situation (i.e., exceptional cases of “*Force Majeure*”).
39. All required information to manage the activated Shared TV Channel at Customer end (channel bandwidth, channel encoding parameters,...) is available on the Belgacom secured website.
40. When the activation of the ordered Shared TV Channel is done, Belgacom will confirm it to the Customer.
41. Once confirmed, the installation shall be subject to the validation of the Customer
42. The Shared TV Channel validation phase is to be performed by the Customer. The Interface ordering will be considered as complete once the Customer has accepted the interface implementation through a firm confirmation
43. Belgacom shall provide the Customer with the necessary support during the validation phase.
44. The Customer shall each time it wants to resell, in a wholesale offer towards another Party, a Shared TV Channel it has already subscribed to, reuse the Shared TV Channel ordering procedure as described here above.

## 6.2 Shared TV Channel Deactivation

### 6.2.1 General

45. The Customer can request the deactivation of a Shared TV Channel.
46. A Shared TV Channel deactivation consists of blocking the access for the Customer to the encryption key attached to the Shared TV Channel to be deactivated.
47. Firm order of Shared TV Channel deactivation shall be done through the use of an order form available on the Belgacom secured website. In case data is missing or is not correct, the template will be rejected. In the latter case, Belgacom will indicate the reasons of rejection on the template. All firm orders will be submitted by email to the SPOC of Belgacom for Wholesale Multicast.
48. The request must be sent via email by the Customer to Belgacom single point of contact in charge of Belgacom Wholesale Multicast Services.

49. The Customer is responsible of specifying the deactivation date. Belgacom cannot be hold responsible for having blocked the access to the key with regard to any complaint coming from the channel owner.

### 6.2.2 Prerequisites

50. The order is relative to an existing Shared TV Channel and must contain its correct identification.

### 6.2.3 Ordering procedure

51. The Customer can deactivate a Shared TV Channel through a firm order. A firm order consists of the requested Shared TV Channel with its associated parameters (the channel name, the channel id, the deactivation date,...).
52. The Customer is notified that in very exceptional situations, significant delays may be experienced:
  - In case of periods of large demands that could not be foreseen,
  - In an emergency situation (i.e. exceptional cases of *force majeure*).

## 6.3 Shared TV Channel Management

### 6.3.1 Shared TV Channel Stop – Specific Case

53. Belgacom is granted the right to block the access of the Customer to an encryption key of a previously ordered Shared TV Channel if the Right holder requires it.
54. The OLO is responsible for requesting the deactivation of a Shared TV Channel it has previously ordered. Belgacom cannot be hold responsible for allowing the Customer to fetch encryption keys of a Shared TV Channel it has previously ordered and for which it confirmed it had the appropriate content rights.

### 6.3.2 Share Channel Stop – General Case

55. Belgacom can decide to stop multicasting a given Shared TV channel. Such a decision can be taken unilaterally without the approval of the Customer.
56. The stop of a Shared TV Channel is non-discriminatory and is enforced for all parties using the Shared TV Channel.
57. Belgacom shall notify the customer at least 2 months prior to the stop of a given Shared TV Channel.
58. The notification shall specify the stop date and the channel name and channel id to be stopped.



59. The stop of a given Shared TV channel consists of blocking the access to the encryption key corresponding to the channel to be stopped.
60. If Belgacom decides to stop a Shared TV channel, the channel is removed from the Belgacom Shared TV Channel pool and cannot be ordered as of the Shared TV Channel stop notification date.
61. Belgacom is not obliged to fill the capacity left free by the Shared TV Channel removed from the Belgacom Share Channel pool with any other content.
62. If Belgacom decides to use the capacity left free by a Shared TV Channel previously removed and to add a new Shared TV Channel, the Customer will be notified 2 months before the Shared TV Channel will be commercially available in the Belgacom retail offer.

## 7 Ordering Dedicated Capacity

63. The Dedicated Capacity is managed via four types of processes:
- Dedicated Capacity initial set-up
  - Dedicated Capacity increase
  - Dedicated Capacity decrease
  - Modification of Dedicated Streams bandwidth configuration

### 7.1 Dedicated Capacity Initial Set-up

64. Before the Customer can order Dedicated Capacity an OLO Access Line needs to be in Service in both Bruxelles area service PoP's (o2STR and o2 MAR).
65. The Dedicated capacity is capacity that the Customer can order to inject its own multicast streams. Belgacom will reserve a range of 32 Multicast IP addresses dedicated to the multicast streams the Customer wants to inject into the Belgacom network.
66. The streams so injected by the Customer are added at PIM core level to the channels of the Shared TV Channel pool and made available to Customer Users which benefit from the multicast functionality (see§ 9).
67. The dedicated capacity is capped at the Ordered Dedicated Capacity. Through shaping any overuse of this capacity will lead to packet drop and signal quality degradation.
68. The Dedicated capacity is made up of:
- The configuration of a VLAN with a bandwidth dimensioned as per the Ordered Dedicated Capacity over OAL's terminated in o2MAR and O2STR Service PoP's.
  - Configuration for connecting o2STR and o2MAR VLAN's to Belgacom PIM core Network.
  - The configuration of all Belgacom IP-DSLAM's with the Multicast IP addresses allocated to the Customer and the bandwidth assigned to each IP address by the Customer.
  - The bandwidth corresponding to the Ordered Dedicated Capacity for Customer's multicast streams.
69. Once the Order request received and validated Belgacom will provide the Customer with the 32 Multicast IP addresses reserved for the Customer dedicated multicast streams.
70. The Customer is responsible for allocating to each Multicast IP address a given bandwidth.
71. The total bandwidth allocated to all multicast IP addresses can exceed the Ordered Dedicated Capacity and all Multicast IP addressed may not be used. The only limitation is the volume actually injected into the Belgacom network.
72. The ordering of dedicated capacity shall be done through the use of a specific template provided on the Belgacom secure website. In case data is missing or is not correct, the template will be rejected. In the latter case, Belgacom will indicate the reasons of rejection on the template. All firm orders will be submitted by email to the SPOC of Belgacom for Wholesale Multicast.
73. The Multicast IP addresses and the corresponding bandwidth shall be transmitted by the Customer to Belgacom via email. Belgacom will validate the sending through a receipt acknowledging the

reception of the email. In case of inconsistency in information provided by the Customer to Belgacom, Belgacom will reject the message and will mention the reasons of the rejection.

74. The Dedicated Capacity ordering is done through two phases: one corresponding to the Multicast initial set-up before the Customer starts its Multicast operations and one covering the period after the operational launch.
75. In the Dedicated Capacity initial set-up the Customer can order up to 25 000 Kbps or less. If the Customer orders less than 25 000 Kbps, Belgacom will make the remaining capacity free so that it could be ordered by anyone else according to a fair split between requestors.

## 7.2 Ordering procedure of Dedicated Capacity Initial Set-up

76. The Customer can order dedicated capacity through a firm order. A firm order consists of the requested dedicated capacity. Together with the firm order, the Customer includes the date when he wants the dedicated capacity to be ready.
77. The Customer is notified that in very exceptional situations, significant delays may be experienced :
  - In case of periods of large demands that could not be foreseen,
  - In an emergency situation (i.e., exceptional cases of *force majeure*),
78. Based upon the Multicast IP range received from Belgacom, the Customer shall allocate the bandwidth to each IP address and communicate that information to Belgacom for further configuration into Belgacom IP-DSLAM.
79. Once confirmed, the installation shall be subject to the validation of the Customer
80. The dedicated capacity validation phase is to be performed by the Customer. The ordering will be considered as complete once the Customer has accepted the dedicated capacity implementation through a firm confirmation.
81. Belgacom shall provide the Customer with the necessary support during the validation phase.

## 7.3 Dedicated Capacity Increase

82. Once the Customer has launched its Multicast activities and has not ordered its complete Available Dedicated Capacity it can order an increase of dedicated capacity. The sum of that capacity increase and the Ordered Dedicated Capacity cannot exceed 25 000 Kbps (Available Dedicated Capacity). Even though the sum is less or equal to the available Dedicated Capacity Belgacom cannot guarantee that the request will be granted. The request approval will depend on the remaining bandwidth in the network.
83. The Dedicated Capacity increase, if accepted, consists of an increase of the Ordered Dedicated Capacity.
84. The ordering of Dedicated Capacity increase shall be done through the use of a specific template provided on the Belgacom secured website. In case data is missing or is not correct, the template will be rejected. In the latter case, Belgacom will indicate the reasons of rejection on the template. All firm orders will be submitted by email to the SPOC of Belgacom for Wholesale Multicast.

85. Before a Dedicated Capacity increase is accepted by Belgacom the following must be fulfilled:
- A dedicated capacity must have been ordered and implemented.
  - The sum of the dedicated capacity increase and the Ordered Dedicated Capacity must be lower or equal to the Available Dedicated Capacity.
  - There is available bandwidth in the Belgacom network.
86. The Customer is notified that in very exceptional situations, significant delays may be experienced :
- In case of periods of large demands that could not be foreseen,
  - In an emergency situation (i.e., exceptional cases of *force majeure*),
87. When the configuration of Dedicated Capacity increase is done, Belgacom will confirm it to the Customer. By confirming the implementation Belgacom ensures that it has performed all the necessary checks under Belgacom reach, aiming at validating the implementation.

## 7.4 Dedicated Capacity Decrease

88. The Customer can decide to decrease its Ordered Dedicated Capacity.
89. Any Dedicated Capacity foregone through a Dedicated Capacity decrease order is considered as available. Belgacom will make the remaining capacity free so that it could be ordered by anyone else according to a fair split between requestors.
90. The Dedicated Capacity decrease, if accepted, consists of a decrease of the Ordered Dedicated Capacity.
91. The ordering of Dedicated Capacity decrease shall be done through the use of a specific template provided on the Belgacom secured website. In case data is missing or is not correct, the template will be rejected. In the latter case, Belgacom will indicate the reasons of rejection on the template. All firm orders will be submitted by email to the SPOC of Belgacom for Wholesale Multicast.
92. Before a Dedicated Capacity decrease is accepted by Belgacom the following must be fulfilled:
- A dedicated capacity must have been ordered and implemented.
  - The Ordered Dedicated Capacity before the order is submitted is greater than 0 (“zero”).
93. The Customer is notified that in very exceptional situations, significant delays may be experienced :
- In case of periods of large demands that could not be foreseen,
  - In an emergency situation (i.e., exceptional cases of *force majeure*),
94. When the configuration of Dedicated Capacity decrease is done, Belgacom will confirm it to the Customer. By confirming the implementation Belgacom ensures that it has performed all the necessary checks under Belgacom reach, aiming at validating the implementation.

## 7.5 Modification of Dedicated Stream Bandwidth configuration

95. The Customer can request a change of the dedicated stream bandwidth configuration.

96. A dedicated stream bandwidth modification consists of modifying the bandwidth allocated to each or some of the Multicast IP addresses reserved to the Customer.
97. The ordering of dedicated stream bandwidth modification shall be done through the use of a specific template provided on the Belgacom secured website. In case data is missing or is not correct, the template will be rejected. In the latter case, Belgacom will indicate the reasons of rejection on the template. All firm orders will be submitted by email to the SPOC of Belgacom for Wholesale Multicast.
98. Before a modification of Dedicated bandwidth is accepted a dedicated capacity must have been ordered and implemented.
99. The Customer can proceed with modification of dedicated stream bandwidth through a firm order. A firm order consists of the modification of the dedicated stream bandwidth.
100. The Customer is notified that in very exceptional situations, significant delays may be experienced :
  - In case of periods of large demands that could not be foreseen,
  - In an emergency situation (i.e., exceptional cases of *force majeure*),
101. When the configuration of the new Multicast IP address bandwidth is done, Belgacom will confirm it to the Customer. By confirming the implementation Belgacom ensures that it has performed all the necessary checks under Belgacom reach, aiming at validating the implementation.
102. Once confirmed, the implementation shall be subject to the validation by the Customer.
103. A dedicated stream bandwidth modification will be allowed twice a year only on a fixed date to be defined by Belgacom. Any supplementary request in the same year will be rejected by Belgacom.
104. Belgacom will communicate the date to the Customer at least three month before the implementation starts.

## 8 Implementation Information

105. The list of Shared TV Channels available in the Belgacom Shared TV channel pool is available on the Belgacom secured website
106. The following information is available for each channel
- The channel name
  - The channel identifier
  - The channel bandwidth
  - The Channel Multicast IP address
  - The Channel encoding features
107. Via the tools offered in the WBA VDSL2 offer the Customer can already check the parameters of the User line.
108. Based upon that information the Customer can define and build its own IPTV offer based upon the capacity of the line.
109. Belgacom cannot be hold responsible for malfunctioning of the Customer offer which does comply with the line and the Shared TV channel parameters.

## 9 Ordering Multicast functionality on a specific User line (WBA VDSL2)

### 9.1 General

110. A commercial contract is signed between a User and the Customer.
111. The ordering of Multicast functionality on a User line is fully based on the WBA VDSL2 ordering framework as specified in WBA VDSL2 Reference Offer – Annex 4 Planning and Operations.
112. Multicast functionality on a User line can be ordered either at line ordering itself or on an existing User line.
  - Either the Customer includes explicitly the Multicast functionality into the order aiming at activating a new WBA VDSL2 User line.
  - Or Multicast is activated on an already ordered WBA VDSL2 User line through a dedicated Multicast activation request.
113. The ordering processes as specified in the WBA VDSL2 Reference Offer in Annex 4 – Planning and Operations are not modified. Orders and Messages remain the same as well as the processes in which they are involved.
114. Only the content of XML's is updated to reflect the possibility to activate Multicast functionality:
  - Concurrently with a WBA VDSL2 User line
  - On an existing WBA VDSL2 line.
115. Regardless the ordering way the Customer introduces a request to activate Multicast; Belgacom verifies that the end-user line aimed by the order is configured with the service quality P3 independently from other services quality configured on the WBA VDSL2 line.
  - If Belgacom cannot find any P3 configured on the end-user line the order will be rejected. The list of reject code related to multicast ordering is available in the XML content description.
  - If the User line is configured with service quality P3 then Belgacom will activate the multicast functionality in the IP-DSLAM relevant for the User line aimed by the order.

### 9.2 Ordering via XML

#### 9.2.1 Generals

116. All exchange of information between Belgacom and the Customer will be done through an electronic system.
117. Reference is also made to the Belgacom Wholesale secured website – Regulatory information – WBA - Information on ordering, for more detailed information on the ordering process via XML.

118. The communication process between Customer and Belgacom is based on SMTP Mail for the transfer, an ACK/NACK protocol and a message file in attachment with a predefined format.
119. The messages that are exchanged between the Customer and Belgacom are encrypted and signed by the sender. Each message contains one order form in attachment that is coded in XML. Technical Info and the order forms for XML ordering are included on the secured website.
120. The Customer prepares the file in the predefined XML format, signs it, encrypts it, attaches it to a mail and sends it to the mailbox of Belgacom. The e-mail address for Wholesale Broadband Access VDSL2 is [WBS@belgacom.be](mailto:WBS@belgacom.be).

## 9.2.2 Definitions

121. Messages required for the management of Multicast on a User line follow the specifications defined in the Wholesale WBA VDSL2 reference Offer – Annex 4.
122. The present paragraph specifies how multicast is integrated in the WBA VDSL2 message framework. Either the XML content of the considered order is impacted or it is not but in both cases the result of the order on the Multicast functionality is described

### 9.2.2.1 Order Messages

#### INITIATED BY THE CUSTOMER

- **PROVIDE NEW:** The Customer can activate Multicast by completing a PROVIDE NEW order with a Multicast activation request. The XML content description is updated to enable the Customer to add Multicast in the WBA VDSL2 PROVIDE NEW order.
- **CEASE:** A CEASE request for a WBA VDSL2 User line on which Multicast is activated deactivates also Multicast on the User line targeted by the CEASE order. The XML content description of a CEASE order is not impacted by the Multicast functionality.
- **CONVERT – cease part and provide part:** The cease part of a CONVERT request on a WBA VDSL2 User on which Multicast is activated triggers the deactivation of Multicast. The XML content description of the cease part of a CONVERT order is not impacted by the Multicast functionality. Because Multicast is not available on other technologies than VDSL2 the provide part of a CONVERT request is not impacted. If a multicast activation request is added to the provide part, the provide part is rejected by Belgacom.
- **PROVIDE CHANGE OWNER:** A PROVIDE CHANGE OWNER request on a WBA VDSL2 line on which Multicast is activated does not activate Multicast on the new WBA VDSL2 User line. The XML content description of a PROVIDE CHANGE OWNER order is not impacted by the Multicast functionality.
- 
- **CHANGE:** The CHANGE order can be used by the Customer to trigger the activation/deactivation of Multicast on an existing WBA VDSL2 User line. The XML content description is updated to enable the Customer to use a CHANGE order to activate/deactivate Multicast on an existing WBA VDSL2 User line.

### **INITIATED BY BELGACOM DUE TO AN ACTION OF ANOTHER CUSTOMER OR FROM THE END-USER CUSTOMER ON HIS VOICE SERVICE**

- CEASE CHANGE OWNER : Triggers the deactivation of Multicast on the WBA User line aimed by a validated PROVIDE CHANGE OWNER of another Customer, or an action started by the end-user-customer of Belgacom
- MOVE – cease part and provide part : : The cease part of a MOVE request on a WBA VDSL2 User on which Multicast is activated triggers the deactivation of Multicast. The provide part of a MOVE request can be completed with a multicast activation request in order to activate Multicast on the new WBA VDSL2 User line.

#### 9.2.2.2 **Answer Messages**

123. An Answer Message can be:

- REJECT: A new set of rejection codes are defined specifically for Multicast. These codes are available on the Belgacom secured website.

#### 9.2.3 **Escalations**

124. An escalation can be requested in case of Belgacom Fault (e.g. implementation mistake)
125. The Customer will in a first phase call (phone) Belgacom to prioritize the order and confirm by e-mail to Car\_LLU. Belgacom will verify this request, and handle it in a manual escalation mode if the request for escalation is justified.
126. An escalation order has no additional cost.

## 10 Forecasting of orders

### 10.1.1 General Principles

127. This chapter describes the forecast process. The forecasts are mandatory to guarantee to respond to orders placed during the provisioning period and this is needed to help Belgacom to plan a reasonable capacity to fulfil customer's demand.
128. Beneficiaries are guaranteed that Belgacom will set up the necessary resources for the period concerned to meet its market needs, independent of the needs of other Beneficiaries. In addition, the forecast entitles the Customer to the conditions for delays determined in the Service Level Agreement.
129. For the orders exceeding the forecasts no guarantee will be offered and they will be carried out, as soon as possible, according to the remaining capacity available. If the forecasted volumes cannot be installed, the Customer will be informed within 30 working days and parties will cooperate to find the most acceptable solution.

### 10.1.2 Processing of Forecasts

130. The following services, part of the whole Multicast Services, must be subject to forecasts.

Product Ordering	Frequency	Forecast period	Forecast Availability date
Activation/Deactivation of Multicast on an User line	Monthly	1 month	The 10 <sup>th</sup> , 2 month before the forecast period (10 <sup>th</sup> of Sept. for forecast of Nov.)
Activation/Deactivation of Shared TV Channels	Half-yearly	6 months (January – June/July - December)	The 10 <sup>th</sup> of Nov (Jan-June) The 10 <sup>th</sup> of May (July-Dec)
Modification of Dedicated Stream Bandwidth	Half-yearly	6 months (January – June/July - December)	The 10 <sup>th</sup> of Nov (Jan-June) The 10 <sup>th</sup> of May (July-Dec)

131. Belgacom will propose an individual forecast to each Customer, based on the mathematical average of the actual ordered volumes of the Customer over the last 6 months. Belgacom will download on the dedicated e-libraries of each Customer the individual forecast proposal. This forecast will be elaborated according to the period specified in the table above and made available as indicated in the table above.

132. The Customer is responsible for the accuracy of the forecast. Therefore, the Customer is requested to confirm or modify this forecast by e-mail (to [cws.forecasting@belgacom.be](mailto:cws.forecasting@belgacom.be)), at the latest one month prior to the first forecasted period in time. Forecast modifications or confirmation shall be done through the use of the templates provided by Belgacom. These templates will only be considered as valid when they are properly completed. In case data is missing or is not correct, the forecast will be rejected (within 5 working days following its reception). In the latter case, the reasons of rejection will be indicated on the template by Belgacom
133. If no confirmation or modification is received by that time, Belgacom will consider the proposed forecasted volumes as confirmed. Once confirmed, the forecasted volumes are globalized by Belgacom into one basket. Capacity reservation, and calendar dimensioning, is done accordingly to fit the needs of the entire market.
134. In the early stage while mathematical forecast computation cannot be performed by Belgacom due to a lack of sufficient data, both Parties will enter into good faith discussions about the submitted forecasts and the feasibility to implement the forecasts concerned.

### 10.1.3 Underrun

135. Underrun occurs when actual ordered volumes are below forecasted volumes. Any underrun mechanism applies to the entire globalized volume of orders of the entire market.
136. A reasonable underrun of the forecasted volumes can be absorbed by Belgacom and has no direct consequences for the Customer. A reasonable underrun is considered to be no more than a 20% deviation of the forecasted volume. In case of severe underrun (i.e. more than 20%) and in case this underrun was caused by a single Customer who excessively increased the volume proposed by Belgacom, Belgacom reserves the right to limit the allowed modification for the forecast of the following 3 months for that Customer to a level deemed necessary by Belgacom.
137. E.g.: The proposed volume for all Customers for month X is 1000 (=average of the actual ordered volumes of the last 6 months.). Some Customers send a modification of their forecasted volume via [CWS.forecasting@belgacom.be](mailto:CWS.forecasting@belgacom.be) and the forecasted volume for all Customers is confirmed at 1500. The actual volume for month X is finally lower than 1200 (1500-20%=underrun). If among the Customers that had sent a modification, the realised volumes are more than 20 % under the modified volumes, they will be identified as responsible of the underrun and won't have the possibility to modify the proposed forecasting during the following 3 months.

### 10.1.4 Overrun

138. Overrun occurs when actual ordered volumes are above forecasted volumes. Any overrun mechanism applies to the entire globalized volume of orders of the entire market.
139. As from the first order exceeding the globalized forecasted volume, independently of which Customer might be the cause of this overrun, all orders of all Beneficiaries for the remainder of the month will be considered 'in overrun'. For any order in 'overrun', no guarantee on Slot Availability will be offered and they will be carried out by Belgacom as soon as possible, according to the remaining capacity available

## 11 Fault Reporting and Repair

140. This section describes the responsibilities of Belgacom and The Customer in fault reporting and repair.

141. This document refers to repair processes which are dedicated to the Multicast offer:

- Multicast functionality on a User line
- The Shared TV channels ordered by the Customer
- The Dedicated Capacity

142. Any Fault related to the WBA VDSL2 services impacting the Multicast TV Services must follow the Fault reporting and repair process defined in the WBA VDSL2 offer.

143. Any default related to OAL services impacting the Multicast TV Services must follow the Fault reporting and repair process defined in the WBA VDSL2 offer.

### 11.1 General Process

144. Repairs are carried out on the Network and TV related equipments after the Customer has informed Belgacom provided the Customer has made the preliminary investigations and is confident that the problem is in Belgacom Network. The Customer is responsible for the repair of the IPTV services for which he has the control and is responsible to filter all non-Belgacom related problems. The Customer, when reporting that there is a problem, has to give precise information about the nature of the problem. Belgacom will, when appropriate, confirm the existence of the problem.

145. If Belgacom becomes aware of a problem on the network or TV related equipments, Belgacom automatically coordinates the necessary actions to resolve the problem according to the applicable arrangements.

146. The maintenance and the development of the Network and TV related equipments may require Belgacom to limit the Multicast services or to suspend it temporarily. Belgacom undertakes to limit the duration of this period to the time that is required for the execution of the work and that duration will, in no way, be longer than the period that Belgacom would require if her own services needed to be suspended. In such cases, Belgacom will inform the Customer in due time at least 48 hours in advance, and communicate the estimated suspension time and the reason of suspension.

### 11.2 Points of Entry for Complaint

147. In case of repair, the following mode of contact between the Customer and Belgacom is possible:

- E-tool for repair tickets

### 11.3 Fault Reporting

148. It is always the Customer that

- 1) Reports faults in the Wholesale Multicast TV Services.
- 2) Receives own Users' fault reports before reporting faults to Belgacom. Belgacom will not take calls directly coming from Users of the Customer.
- 3) Handles own Users' fault reports before reporting faults to Belgacom.

149. It is the Customer's responsibility to check that there is sufficient ground to assume that the fault is with Belgacom.

## 11.4 Customer's liabilities in connection with fault reporting

150. For fault reporting, the Customer will contact Belgacom the e-tool.

151. Before contacting Belgacom, the Customer will test the concerned faulty equipment to ensure that the fault is attributable to Belgacom. The Customer is responsible for transmitting all necessary information requested by Belgacom. In the following cases the trouble ticket creation will be rejected:

- Information is incomplete

152. The Customer will possibly communicate to Belgacom:

- Measurements from equipment on the Customer's side that can help in solving the fault (if available).

153. It is always the Customer that receives own Users' fault reports regarding the Wholesale Multicast TV services before reporting faults to Belgacom. In case Belgacom receives fault reports regarding the Wholesale Multicast TV services, Belgacom will refer the User to the Company with whom he has signed an agreement.

154. When the Customer receives a fault from one of his Users for Wholesale Multicast TV Services, the Customer performs a first diagnostic.

- In case the issue does not require a Belgacom intervention, the Customer manages the issue and contacts the User once the issue is solved and closed.
- On the opposite, if the issue requires a Belgacom intervention (typically for network or TV related equipments issues), the Customer continues the issue resolution process with Belgacom.

## 11.5 Belgacom's liability in connection with fault reporting

155. Belgacom starts the fault localization and performs repair activities during working hours.

156. The Customer recognizes that:

- if necessary, the Customer is required to disconnect the terminal equipment at the User site upon Belgacom's request to carry out its proper measurements;
- The Customer's repair request must relate to the type of service for which the Wholesale Multicast TV service has been ordered;
- During the repair process the Customer may submit additional information in respect of a specific repair request, cancel a repair request or change a repair request.

157. Belgacom reports the result of the repair activities to the Customer immediately upon repair.
158. Any follow-up feedback requested by the Customer, either during the repair period, after additional tests and rejection or acceptance of the repair action, or once the fault is fixed, will be taken care of through the repair team for Multicast TV Services;
159. In any case of planned maintenance and repair that can affect the Multicast TV services, Belgacom shall inform the Customer.
160. In case the Customer contacts Belgacom by phone about an ongoing repair action, Belgacom will inform the Customer of the current repair status.

## 11.6 Special conditions in connection with Repair

161. In fault situations where the responsibility for the fault cannot immediately be placed, and where Belgacom makes coordinated efforts with one or more Customers, settlement is made or arranged after conclusion of the Repair.

## 11.7 Repair Request and Feedback

### 11.7.1 Multicast on an User Line

162. Any Customer's Repair Request concerning an issue rooted in a WBA VDSL2 service must follow the Repair process as specified in the WBA VDSL2 Offer.

### 11.7.2 Shared TV Channels

163. Customer's request for Repair at Shared TV Channel level must be entered via e-tools and will be answered by the Belgacom Operations TV team.
164. No Direct calls from the Customer's User will be accepted.
165. The Customer has to provide the Channel name and the Channel ID on which it has detected an issue.
166. Any Repair request which does not include the information required here above or including incorrect or unknown information will be rejected.
167. Any Repair request related to a channel which has not been ordered by the Customer will be rejected.

### 11.7.3 Dedicated Capacity

168. Any Customer's request for Repair at Dedicated Capacity Level must follow the OAL Repair process as defined in the WBA VDSL2 Offer.

## 11.8 Wrongful repair request

169. To encourage the Customer to perform a check first on the equipment's part of its service delivery towards its User, Belgacom will bill an incentive fee to the Customer in case of a repair request for which the fault cause is not rooted at Belgacom whereas Belgacom has performed the necessary investigations to prove it.

170. There will be an indication of the trouble ticket reference and the cause of the wrongful repair.

## 12 Phases in the provisioning of the Multicast Services

171. The way of provisioning the Multicast TV Services to the Customer will evolve according to the following 2 successive Phases: Friendly User Testing Phase and Full Commercial Phase.

### 12.1 Friendly User Testing Phase

172. During the Friendly User Testing phase, later referred to as FUT, Belgacom will introduce and support the Customer to get acquainted with the processes and systems in scope of the Multicast Services.

173. Each of the Parties will have to agree on the date of successful completion of the Friendly User Testing Phase. The FUT phase should cover a period of 20 working days.

174. The FUT Phase is executed at one Service PoP, linked to at maximum two LEX's enabled for VDSL2. The number of 'friendly user' Users (to be provided by the Customer) is set at maximum 24 per Customer.

### 12.2 Full Commercial Phase

175. The Full Commercial Phase will entirely be based on Customer's firm orders transmitted by the Customer. The number of orders must be reasonable and progressive to avoid that the order intake services of Belgacom are overloaded by large amounts of initial orders.

## 13 Shared Channel Change Management

### 13.1 General

176. The multicast stream change management aims at describing the requirements to be followed whenever a change related to Shared channel is triggered by Belgacom
177. Changes impacting shared channels are classified into 4 categories each being assigned a specific change management notification delay.
178. Shared Channel changes are classified as follow:

Change Type	Description
Change Type #1	Changes for which Belgacom reasonably does not foresee that it will require any adaptation at Customer side but which might lead to a shared channel stream temporary interruption. Such a change is notified to the Customer 24 hours before the change is performed in live environment.
Change Type #2	Changes which require adaptation at Customer side but without any modification of Shared Channel stream features (typically Multicast IP address change). Such a change will be notified three weeks before the change is performed in live environment and will require coordination with the Customer for the definition of the change time and date.
Change Type #3	Minor changes which require adaptation at Customer side with an impact on the Shared Channel stream features. Such a change will be notified three months before the change is performed in live environment and will require coordination with the Customer for the definition of the change time and date.

Change Type #4	Major changes which require adaptations at Customer side with an impact requiring close coordination between parties to achieve a successful change release. Such a change will be notified at least 6 months before the change is performed in live environment. An estimated go live date will be provided in the change notification but Belgacom reserves the right to push back the go live date afterwards under the conditions that the Customer is notified at least 4 weeks before the previous go live date.
----------------	--

- 179. Each time that Belgacom identify a need for a change it will notify the Customer about the change type according to delay as specified in table above.
- 180. Each change notification will be accompanied with a change specification and possible impact on the shared channel stream.
- 181. Depending on the change type Belgacom will provide the Customer with the necessary information to enable the Customer to perform its own impact assessment.
- 182. Depending on the change type Belgacom will provide the Customer with a multicast stream sample embedding the change to enable the Customer to perform its own lab testing
- 183. Depending on the change Belgacom will ensure that a test multicast stream embedding the change will be available in live environment to enable the Customer to perform its own live testing.
- 184. The Customer is responsible for performing all the tests the Customer considers as required to validate the modifications having been brought to its service delivery equipment's due to the shared channel stream change.

## 14 Glossary

- **TV Related Equipments:** Equipments which are not considered as network equipments but which are required for the provisioning of Shared TV Channels.

## Appendix A: Statement of requirements, template for the Customer

### General

185. This appendix includes a non-exhaustive list of items that should be included in the Statements of Requirements (SOR). This template is only a guideline. It is the freedom of both parties to discuss the content of the SOR.

### Basic information

#### Registered name and address of Customer

Customer name :  
Address :  
Postal code and city :  
Country :  
Telephone number :  
Fax number :  
VAT registration number :  
Trade register (\*) :

### Confidentiality agreement

186. The Parties can choose to sign a confidentiality agreement as part of the SOR. The statements included in this agreement are to be determined by the parties.

## Key Contacts list

### Key project dates

	<b>Date required by Customer</b>	<b>Indicative dates from Belgacom</b>
Requested date to start Friendly User Test		
Requested bringing into service date of Wholesale Multicast ordering		

### Wholesale Multicast Products and Services Customer wishes to obtain from Belgacom

187. Please indicate what services you wish to obtain from Belgacom in scope of Multicast TV Offer.

<b>Name</b>	<b>Interest</b>
Start-up pack including multicast functionality on WBA VDSL2 User line and fifteen sharedTV channels	Yes/no
Multicast Dedicated capacity	Yes/no



together  
with



# Wholesale Multicast

## Annex 4: SLA

Created on: 06 March 2012

belgacom





together  
with



# 1 Table of contents

<b>1</b>	<b>Table of contents .....</b>	<b>2</b>
<b>2</b>	<b>Object .....</b>	<b>4</b>
<b>3</b>	<b>Scope .....</b>	<b>5</b>
<b>4</b>	<b>Prerequisites .....</b>	<b>6</b>
<b>5</b>	<b>Timers .....</b>	<b>7</b>
5.1	<b>Provisioning.....</b>	<b>7</b>
5.1.1	Ordering Multicast functionality on a specific End User Line.....	7
5.1.2	Provisioning of Shared TV Channel .....	8
5.1.3	Modification of dedicated stream Bandwidth.....	9
5.2	<b>Repair .....</b>	<b>10</b>
5.2.1	Repair Timer on the End User line .....	10
5.2.2	Repair Timer on Shared TV channels .....	10
5.2.3	Repair Time on Dedicated Capacity .....	11
5.2.4	Repair Time on Encryption Key Interface .....	11
<b>6</b>	<b>Shared TV channels Availability .....</b>	<b>12</b>
<b>7</b>	<b>Wrongful Repair Requests.....</b>	<b>13</b>
<b>8</b>	<b>Documented reports .....</b>	<b>14</b>
<b>9</b>	<b>Terms and Conditions for Compensations.....</b>	<b>15</b>
9.1	<b>General .....</b>	<b>15</b>
9.2	<b>Provisioning Compensations.....</b>	<b>16</b>
9.2.1	Compensation for Ordering Multicast functionality on a specific End User Line .....	16
9.2.2	Shared TV Channel Set-up Timer Compensations.....	16
9.2.3	Provisioning of Modification of Dedicated Stream Bandwidth Timer Escalations.....	16
9.3	<b>Repair Timer Compensation.....</b>	<b>16</b>
9.3.1	Repair Shared TV Channel .....	17

**10 Escalation procedure ..... 18**

## 2 Object

1. The present document defines the Terms and Conditions upon which Belgacom will deliver installation and maintenance of Wholesale Multicast Services. For all operational aspects, reference is made to the Annex 3 - Planning and Operations.
2. The terms and conditions of this SLA are applicable within the limits of the forecasted volumes provided by the Customer in line with the forecasting mechanism and deviations described in the Annex 3 (Planning and Operations).

### 3 Scope

3. The scope of this document is to set a framework for operational collaboration between Belgacom and Customer that ensures the respect of the fixed deadlines and an acceptable quality of the provided Services.
4. The intention is to minimize the risk of shortcomings and so motivate all parties to respect the thresholds set in this SLA and to provide an incentive to enhance the performance of both parties.
5. Both parties agree that the objective of this document is to optimize operational collaboration and all efforts should be taken to avoid compensations or penalty fees.
6. The working of this Service Level Agreement is subject to a learning curve, i.e. the current values included are values that are to be evaluated on a regular basis and should exclude excessive peaks in ordering, i.e. very concentrated ordering in a very short period of time, and must be analyzed when happening. This document is an evolving document that may be adapted and revised regularly.

## 4 Prerequisites

7. Both parties agree to respect the content of this document and to offer Services as described in this document.
8. When specific follow up or support needs to be performed, both parties are obliged to provide a SPOC with its respective name, telephone number or e-mail.
9. Timers in this document expressed in days are always working days unless specified otherwise. For a timer of x days, the action must be completed before end of working day x after reception of the order or other Customer message, unless specified otherwise. Timers expressed in months consist of 21 working days. Under the present document, a working day for order purposes is considered as being from 8h00 to 16h30 excluding Saturday, Sunday, Belgian and Belgacom. holidays. Belgacom holidays are 2 January and 26 December.
10. In case of massive orders, provisioning will be done on project-basis. In that case, planning can be negotiated between Customer and Belgacom. The Customer must upfront inform Belgacom when communicated forecasted volume is exceeded. In that case, although SLA will not apply, Belgacom will manage, as far as possible, this increase of orders according to its best suitability.
11. In order to ensure reasonable operational workload, the Customer should ensure a reasonable spread of his orders during the month. For the execution of the present Contract, the maximum daily volume intake is defined as 10% of the monthly forecasted volumes. The orders exceeding on a daily basis the maximum daily volume intake are exempted from the SLA conditions. Belgacom will execute these orders on a best effort basis.
12. Timer violations outside the working hours are not logged as such and shall not be used to claim service shortage.
13. The Service Level Agreement is not valid in case of events which falls outside the scope of responsibility of Belgacom as defined in the “General Terms of Conditions”.
14. Timers that are delayed due to Customer are not valid within this Service Level Agreement.

## 5 Timers

15. This paragraph includes the most relevant timers in the operational processes framework. The purpose is that these timers will be reviewed periodically based on experience.
16. The timers included below are binding and a revision of the latter is possible after BIPT approval.

### 5.1 Provisioning

#### 5.1.1 Ordering Multicast functionality on a specific End User Line

17. This paragraph addresses the ordering of Multicast on an existing WBA VDSL2 End User line.
18. Multicast activated on a WBA VDSL2 line will enable the end user's decoder to call a specific Multicast Stream and to receive it accordingly. The ordering of Multicast functionality on a specific User line corresponds to the activation of the multicast functionality at IP-DSLAM level on the WBA VDSL2 line of a given User.
19. The ordering of Multicast in the same order as for a WBA line is out of the scope of this document. In this specific case the requirement defined in the WBA VDSL2 offer are applicable.
20. Adding Multicast in the activation of a WBA VDSL2 line for an individual User does not change timers committed in the WBA VDSL2 offer.

##### 5.1.1.1 Multicast Provisioning Validation Timer

21. The Multicast provisioning validation timer starts the day following the day Belgacom has sent an ACK message (see WBA VDSL2 offer – Annex 3 Planning and Operations) as reply of the Customer order for activating Multicast functionality on User line.
22. The Multicast provisioning validation timer ends on the sending date of the Validate message sent by Belgacom.
23. The Multicast provisioning validation timer is not valid if the order sent by the Customer has been rejected and a Reject message has been sent by Belgacom.
24. Any Multicast functionality activation order for which the Multicast provisioning validation timer has been exceeded due to events falling outside the scope of responsibility of Belgacom (as specified in Annex 1 General Terms and Conditions) will not be considered as cases for which Belgacom has not met the Multicast provisioning execution timer.

<b>Multicast Provisioning Validation Timer</b> (to be respected by Belgacom)	<b>Percentage of orders validated within the corresponding validation timer</b>
---	---

30 minutes	50%
2 working days	95%
5 working days	99%

### 5.1.1.2 Multicast Provisioning Execution Timer

25. The Multicast provisioning execution timer starts the day following the day the validate message has been sent to the Customer by Belgacom.
26. Any Multicast functionality activation order for which the Multicast provisioning execution timer has been exceeded due to events falling outside the scope of responsibility of Belgacom (as specified in Annex 1 General Terms and Conditions) will not be considered as cases for which Belgacom has not met the Multicast provisioning execution timer.
27. The Timer ends on the sending date of the done confirmation by Belgacom.

	Timer
<b>Multicast Provisioning Execution Timer</b> (to be respected by Belgacom)	8 Working Days

28. Belgacom guarantees that the Multicast provisioning execution timer will be met for 95% of Multicast functionality activation orders on a monthly basis.

### 5.1.2 Provisioning of Shared TV Channel

29. This paragraph addresses the set-up and configuration of a Shared TV Channel for a given Customer
30. The Shared TV Channel set-up timer is related to the necessary activities required to activate the provisioning towards the Customer of the encryption key required for decrypting the requested Shared TV channel transported over the Belgacom multicast network.
31. The Shared TV Channel set-up timer starts the day following the day Belgacom has sent an ACK message as reply of the Customer order for activating a Shared TV Channel (See Annex 3 Planning and Operations).
32. Any Shared TV Channel activation order for which the Shared TV Channel set-up timer has been exceeded due to events falling outside the scope of responsibility of Belgacom (as specified in Annex 1 General

Terms and Conditions) will not be considered as cases for which Belgacom has not met the Shared TV Channel set-up timer.

33. The Timer ends on the sending date of the done confirmation by Belgacom. The timer does not include the validation phase to be performed by the Customer (see Annex 3 – Planning and Operations)

34. The set-up and configuration of a Shared TV channel timer is set at:

	Timer
<b>Shared TV Channel Set-up Timer</b> (to be respected by Belgacom)	10 working days

35. Belgacom guarantees that the Shared TV Channel Set-up timer will be met for 100% of Shared TV Channel activation orders.

### 5.1.3 Modification of dedicated stream Bandwidth

36. This paragraph addresses the modification of Dedicated stream bandwidth configuration which enables the Customer to modify the bandwidth allocated to the Multicast streams part of its Dedicated Capacity

37. The modification of dedicated stream bandwidth timer is related to the necessary activities required to modify the bandwidth allocated to Multicast IP addresses of Multicast streams dedicated to the Customer.

38. The modification of dedicated channel bandwidth timer starts on the fixed date notified to the Customer by Belgacom three months before and provided the Modification of Dedicated stream bandwidth order issued by the Customer has been validated and a validate message sent by Belgacom.

39. Any Modification of dedicated stream bandwidth order for which the modification of dedicated stream bandwidth timer has been exceeded due to events falling outside the scope of responsibility of Belgacom (as specified in Annex 1 General Terms and Conditions) will not be considered as cases for which Belgacom has not met the modification of dedicated stream bandwidth timer.

40. The Timer ends on the sending date of the done confirmation by Belgacom. The timer does not include the validation phase to be performed by the Customer (see Annex 3 – Planning and Operations)

41. The set-up and configuration of Shared TV channel timer is set at:

	<b>Timer</b>
<b>Modification of dedicated stream bandwidth timer</b> (to be respected by Belgacom)	25 working days

42. Belgacom guarantees that the modification of dedicated stream bandwidth timer will be met for 100% of Modification of dedicated stream bandwidth orders.

## 5.2 Repair

### 5.2.1 Repair Timer on the End User line

43. The repair timer of a WBA WDSL2 line on which Multicast has been activated is the same as the repair timer on a WBA VDSL2 line without Multicast.
44. The repair SLA specifications for a WBA VDSL2 line with Multicast must fulfill the specifications as defined in WBA VDSL2 offer – Annex 5 or Annex 5A depending on the SLA activated on the User line.

### 5.2.2 Repair Timer on Shared TV channels

45. This timer is related to incidents which are rooted neither in the WBA VDSL2 line nor the multicast functionality and targets only channels offered in the Belgacom Shared TV Channel pool and previously ordered by the Customer. Multicast streams injected by the Customer in case it ordered the Dedicated Capacity are out of the scope of this timer.
46. This timer covers issues arising from Shared TV Channel IPTV platform up to the injection point into the Belgacom network.
47. The repair time window for Shared TV Channels is done by trouble ticket handling during working days.
48. The repair services on Shared TV Channels with local/regional coverage are offered as per best effort principles
49. Belgacom ensures a repair time only on:
  - Shared TV Channels the Customer has ordered and for which it still has a valid subscription
  - Shared TV Channels which have a nation-wide coverage. Shared TV Channels with local/regional coverage are out of the scope of this repair timer.
50. The Shared TV Channel differentiation between local/regional and nation-wide coverage will be available on the Belgacom Secured Website.
51. The Repair Timer is not applicable in case of Force Majeure as specified in Annex 1 General Terms and Conditions.
52. The Repair time Timer is not applicable in case of Maintenance activities to be performed by Belgacom during maintenance windows defined between 06:00 AM and 12:00 AM working days.
53. In case of an outage on an HD Shared Channel Belgacom reserves the rights to replace it with its SD equivalent in order to reduce the Shared TV Channel User impact. This time required to perform that activity is considered as not included in the Repair time Timer. A stop clock and a start clock will be done respectively when the replacement activity starts and when it stops.

The repair timer on Shared TV Channel starts when Belgacom receives a Trouble ticket based on the issue description communicated by the Customer and ends at the moment Belgacom has notified the Customer that the trouble ticket is closed

	<b>Timer</b>
<b>Repair Timer Shared TV Channel</b> (to be respected by Belgacom)	4 working hours (excluding local/regional channels)

54. On a monthly basis Belgacom ensures that 90% of trouble tickets received by Belgacom from the Customer and falling in the Shared TV Channel Repair timer category as specified here above will be resolved within 4 hours.
55. Belgacom will not be liable for any delay or failure to fulfill its obligations arising from any event beyond its reasonable control, such as for instance but without limitation: natural disasters (e.g. fire, flooding, earthquake), weather conditions (e.g. heavy rain, thunderstorms, snow, sun interference), strikes or intervention by a third party who does not act under the responsibility of that Party (e.g. looting, rioting, sabotage, unauthorised handling of Belgacom equipment's or cabling by broadcasters at broadcaster location).

### 5.2.3 Repair Time on Dedicated Capacity

56. The repair timer of Dedicated Capacity is the same as the repair timer specified for an OAL as described in the WBA VDSL2 offer Annex 5.

### 5.2.4 Repair Time on Encryption Key Interface

57. The repair timer of Encryption Key Interface is the same as the repair timer specified for an OAL as described in the WBA VDSL2 offer Annex 5.

## 6 Shared TV channels Availability

1. The availability of a shared TV channel is defined as the percentage of time that the channel is operational during a given time period.
2. The availability calculations of shared TV channels will be done on a monthly basis.
3. The calculation is based on reports extracted from the information collected on the probes connected at the injection point of the Belgacom network.
4. Local and regional Shared TV Channels are out of the scope of the Shared TV Channel availability calculations.
5. A Shared TV Channel will be considered as available in following cases:
  - Belgacom planned work
  - Broadcaster planned work
  - Unavailability rooted outside the scope of responsibility of Belgacom
  - Case of Force Majeure
  - A HD channel replaced by a SD channel.
6. The monthly availability score will be calculated as an average of the availability of the Shared TV Channels the Customer has ordered.
7. On a yearly basis the months showing the best and the worst monthly availability score are filtered out for the yearly score calculation.
8. The yearly availability score is calculated as the average of the monthly availability score of the remaining 10 months.
9. Belgacom commits to the following yearly availability score

	<b>Timer</b>
<b>Shared TV Channel Yearly Availability</b>	99,8% (excluding local and regional Shared TV Channels)

10. If Belgacom does not meet the Shared TV Channel yearly availability, Belgacom will compensate the Customer as defined in the Terms and Conditions for Compensation chapter specified in the present document.

## 7 Wrongful Repair Requests

11. Belgacom will charge the Customer with the fee related to Wrongful Repair Requests (see Annex 5 – Pricing and Billing) if the fault is not attributable to Belgacom or if the fault results from the abnormal use of the line or any other Customer - or end user of the Customer - fault.

## 8 Documented reports

12. Belgacom will provide every two months the BIPT and each Customer with documented reports on the Services ordered by this Customer during these two months, containing all information needed to calculate the provisioning KPI's described in this document.
13. Services targeted by this provisioning report are:
  - Multicast activation on an existing WBA VDSL2 User line
  - Shared TV Channels
  - Dedicated Capacity
  - Modification of dedicated channel bandwidth
14. This information will be transmitted to the Customer individually, on a confidential basis.
15. This information will be provided under the form of a structured file (Excel or CSV format), and will include at least the following data:
  - For Multicast activation order on an existing WBA VDSL2 User line: Customer, CID, Order ID, product, date of order, Service Requested Date (SRD), Validate XML date, Done XML date.
  - For Shared TV Channel: Customer, Shared TV Channel Name, Shared TV Channel ID, Order ID, date of order, Service Requested Date, Validate message date, Done message Date.
  - For Dedicated capacity: Customer, Order ID, date of order, Service Requested Date, Validate message date, Done message Date.
  - For Modification of dedicated channel bandwidth: Customer, Order ID, date of order, Service Requested Date, Validate message date, Done message Date.

## 9 Terms and Conditions for Compensations

### 9.1 General

16. The MULTICAST offer contains SLA levels for shared channels that are the same as the timers which Belgacom applies to its own retail entity, thus ensuring mere non-discrimination. The MULTICAST offer even goes beyond non-discrimination by foreseeing compensations to the Customer in case of non respect with the timers concerned, which is not guaranteed by Belgacom to its end users or to its retail arm
17. Compensations are applicable in the cases that Belgacom has not respected its commitment within the timers stipulated by the present SLA or other exclusion as described in this document
18. Compensations will be settled through a Customer's invoice without VAT.
19. Payment by Belgacom of these compensations shall be sole redress available to the Customer in the event the guaranteed is not complied with.
20. Compensations are only applicable if the volumes per month are below the defined limits in the forecasting process as described in the Annex 3 – Planning and Operations.
21. In case of timer escalations, the consequences as described further in this paragraph shall be applicable to Belgacom taking into account the concerned item (Multicast activation on User line, Shared TV Channel, Dedicated Capacity, Modification of Dedicated stream bandwidth ). Compensations are calculated per timer without cascade effect, meaning that if a timer has been exceeded, compensations will only be due once.
22. The Customer needs to provide Belgacom with the necessary information in case of a delayed repair or any shortage of Belgacom that gives cause for the compensations described in this Service Level Agreement. Belgacom will upon receipt verify this information. When this verification appears that the information of the Customer shows a shortcoming of Belgacom that gives cause for paying compensation, this payment will be done immediately and automatically.
23. The Customer will submit a detailed request for compensation to Belgacom including for every delayed repair at least date and hour notified/resolved, circuit id (only for multicast functionality activation on user line), problem and product type. The validity of each request for compensation will be examined by Belgacom and in case of rejection Belgacom will motivate its decision.

## 9.2 Provisioning Compensations

### 9.2.1 Compensation for Ordering Multicast functionality on a specific End User Line

24. Since the ordering of Multicast functionality on a specific End User line follows the WBA VDSL2 ordering process compensations are as specified in the WBA VDSL2 Reference Offer.

### 9.2.2 Shared TV Channel Set-up Timer Compensations

25. The Shared TV Channel timer compensation includes the provisioning of Shared TV Channel when the provisioning of a Shared TV Channel was not completed within the timer stipulated in the present SLA. Except in the event of other deadlines being agreed with the Customer, Belgacom undertakes to take all steps to set up the Shared TV Channel. If this deadline cannot be respected, Belgacom undertakes to inform the Customer of the reasons for the delay and also to communicate the new deadline for meeting his request.
26. The Customer will be entitled to the following compensations:

	<b>Compensation</b>
<b>Shared TV Channel Set-up Timer Compensation</b> (to be respected by Belgacom)	€ 10 per Shared TV Channel per working day delayed with a maximum of 120€

### 9.2.3 Provisioning of Modification of Dedicated Stream Bandwidth Timer Escalations

27. The Modification of Dedicated Stream Bandwidth timer compensation includes the provisioning of Modification of Dedicated Channel Bandwidth when the provisioning of Modification of Dedicated Channel Bandwidth was not completed within the timer as stipulated in the present SLA. Except in the event of other deadlines being agreed with the Customer, Belgacom undertakes to take all steps to set up the Modification of Dedicated stream Bandwidth. If this deadline cannot be respected, Belgacom undertakes to inform the Customer of the reasons for the delay and also to communicate the new deadline for meeting his request.
28. The Customer will be entitled to following compensation.

	<b>Compensation</b>
<b>Modification of Dedicated Stream Bandwidth Timer Compensation</b> (to be respected by Belgacom)	€ 10 per working day delayed with a maximum of 120€

## 9.3 Repair Timer Compensation

### 9.3.1 Repair Shared TV Channel

29. Interruptions of service which last more than the timers defined in Section “Repair Timer on Shared TV Channel”, and are the fault of Belgacom shall entitle the Customer to a reimbursement of the rental fee corresponding to the duration of the interruption.. In these cases, Belgacom shall notify the Customer of the timeframe in which his request will probably be carried out. The timeframe taken into consideration for calculating the reimbursement amount starts on the day after the day the trouble ticket has been created by the up to and including the day that the Service is restored.
30. The Customer will be entitled to a compensation that corresponds to 3% of the monthly recurring fee per Shared TV Channel.

	<b>Compensation</b>
<b>Repair Timer Compensations</b> (to be respected by Belgacom)	0,5 % of monthly recurring fee per working hour delayed

## 10 Escalation procedure

31. By default Internal Escalations are performed automatically. The target of departments is to limit the number of external escalations by launching pro-actively internal escalations as soon as timers are exceeded.
32. Escalation is possible when a trouble ticket has been created.
33. External Escalation can be initiated by the Customer to level 1 at Belgacom after the defined timer has been passed. Further escalation can be requested to level 2 at day of first external escalation submitted +1 day. Escalation to level 3 can be requested at day of first external escalation submitted + 2 days.
34. Immediately External Escalation to Level 2 and Level 3 is accepted from persons at the same level in the Beneficiaries Organization in case the Level 1 escalation is done before and the level 1 escalation shows structural problems or unavailability. Level 2 and 3 will first check whether lower escalation steps have been taken, before proceeding.
35. The escalation matrix is available on the Belgacom Wholesale website.

Wholesale Multicast

# Annex 5: Pricing and Billing

Created on: 06 March 2012

belgacom

together with





together  
with



# 1 Table of contents

<b>1 Table of contents .....</b>	<b>2</b>
----------------------------------	----------

<b>Preliminary notes .....</b>	<b>3</b>
--------------------------------	----------

<b>2 Pricing.....</b>	<b>4</b>
-----------------------	----------

2.1 Start-up fee .....	4
------------------------	---

2.2 Multicast functionality.....	4
----------------------------------	---

2.2.1 Onetime Configuration fee of Multicast on a WBA VDSL2 User line.....	4
--	---

2.2.2 Monthly Multicast Recurring Fee per User Line .....	5
---	---

2.3 Shared TV Channels.....	5
-----------------------------	---

2.3.1 Onetime Fees.....	5
-------------------------	---

2.3.2 Monthly Shared TV Channel Recurring fee .....	6
---	---

2.4 Shared TV Channels Interface .....	7
--	---

2.4.1 Shared TV Channel Interface Set-up.....	7
---	---

2.4.2 Shared TV Channel Interface Decommissioning .....	7
---	---

2.5 Dedicated Capacity .....	7
------------------------------	---

2.5.1 Onetime Fees.....	8
-------------------------	---

2.5.2 Dedicated Capacity Decommissioning .....	9
--	---

2.5.3 Monthly Ordered Dedicated Capacity Recurring fee.....	9
---	---

2.6 Wrongful repair request.....	9
----------------------------------	---

2.7 SLA documented reports .....	9
----------------------------------	---

<b>3 Billing.....</b>	<b>10</b>
-----------------------	-----------

3.1 Preliminary.....	10
----------------------	----

3.2 Recording and storage of billing data .....	10
---	----

3.3 Confirmation of charging principles .....	11
---	----

3.4 Invoices.....	12
-------------------	----

3.5 Payment .....	13
-------------------	----

3.6 Disputes .....	13
--------------------	----

## Preliminary notes

1. All prices included in this Price List are expressed in Euro, VAT excluded. Structure and prices of the below Price List are subject to further adaptations.
2. Principle: all Multicast Fees as described in Annex 6, Pricing and Billing, will be invoiced to and are to be paid by the Customer whenever relevant.
3. The Customer shall at least order and activate fifteen Shared TV Channels before it could order its first Multicast activation on a WBA VDSL2 User line.

## 2 Pricing

### 2.1 Start-up fee

4. The Startup fee is charged to Customer, operator, consultant or other that requires explanations by Belgacom Multicast specialist (Product Management and /or Customer Care service) on the offer content (e.g. this fee is not charged for negotiation meeting). This fee due until the Shared TV channels included in the start pack are configured and activated.

Information on Multicast Services	Price
Rate per hour per Belgacom person	€102,49

### 2.2 Multicast functionality

5. The multicast functionality is the functionality activated at IP-DSLAM level to enable the User to call a Multicast Stream and to receive it accordingly.

#### 2.2.1 Onetime Configuration fee of Multicast on a WBA VDSL2 User line

6. The Customer will be invoiced the following amount each time that it activates multicast on an existing WBA VDSL2 User line.

	Price
Activation/Deactivation fee of Multicast on a WBA VDSL2 User line	€14,32

7. If Multicast is activated along with a WBA VDSL2 User line, WBA VDSL2 activation fee as specified in the WBA VDSL2 Offer are applicable and should not be increased by the above mentioned fee.
8. By default Multicast is deactivated along with a WBA VDSL2 User line and the WBA VDSL2 activation fee as specified in the WBA VDSL2 Offer is applicable and should not be increased by the above mentioned fee.

## 2.2.2 Monthly Multicast Recurring Fee per User Line

	Price
Monthly Multicast Recurring Fee per User Line	€0,54

9. Before activating Multicast on its first WBA VDSL2 User line, the Customer must at least order fifteen Shared TV Channels which will be considered as a Start Pack. A Radio Shared TV Channel is not considered as qualified for the Start Pack so that it shall be composed of SD or HD Shared TV Channels only.

## 2.3 Shared TV Channels

### 2.3.1 Onetime Fees

#### 2.3.1.1 Encryption Key Interface Set-up

10. The Customer will be invoiced the following fee each time it requests the set up of an Encryption Key Interface on an existing OAL (redundant or not):

	Price
Encryption Key Interface Set-up Fee	€349,53

#### 2.3.1.2 Encryption Key Interface Decommissioning

11. The Customer will be invoiced the following fee each time it requests the decommissioning of an Encryption Key Interface on an existing OAL (redundant or not):

	Price
Encryption Key Interface Decommissioning Fee	€264,95

#### 2.3.1.3 Shared TV Channel Activation

12. The Customer will be invoiced the following fee each time it activates a given Shared TV Channel. The Shared TV Channel activation fee is independent from the type of channel (Radio, SD, HD).
13. The fee specified below will be invoice per Shared TV Channel activated independently whether multiple Shared TV Channels have been ordered through the same order.

	<b>Price</b>
Shared TV Channel Activation Fee	€354,38

#### 2.3.1.4 Shared TV Channel Deactivation

14. The Customer will be invoiced the following fee each time it deactivates a given Shared TV Channel. The Shared TV Channel deactivation fee is independent from the type of channel (radio, SD, HD).
15. The fee specified below will be invoice per Shared TV Channel deactivated independently from whether multiple Shared TV Channels have been deactivated through the same order.

	<b>Price</b>
Shared TV Channel Deactivation Fee	€285,93

#### 2.3.2 Monthly Shared TV Channel Recurring fee

16. Belgacom offers the Customer with three types of channels (Radio, SD and HD). Each channel type has a dedicated monthly recurring fee and is invoiced on per channel basis.

<b>Monthly Shared TV Channel recurring Fees</b>	<b>Price</b>
Monthly Radio Shared Channel Recurring Fee	€407,28
Monthly SD Shared Channel Recurring Fee	€2225,29
Monthly HD Shared Channel Recurring Fee	€3518,49

17. The Customer shall inform Belgacom upfront when a Customer's User intends to resell to or otherwise put the Wholesale Multicast Services at the disposal of a third party, so that the correct fees for the use of shared TV channels can be applied.
18. This requirement is applicable to any Shared TV Channel.
19. This requirement is applicable each time the Customer resells in a wholesale offer a Shared TV Channel to another party. The Customer will be invoiced the price per channel as many time as there are parties the Customer has resold the Shared TV Channel to.

## 2.4 Shared TV Channels Interface

### 2.4.1 Shared TV Channel Interface Set-up

20. The Customer will be invoiced the following fee each time it requests the set up of a Shared TV Channel Interface on an existing OAL (redundant or not):

	Price
Shared TV Channel Interface Set-up Fee	€773,51

### 2.4.2 Shared TV Channel Interface Decommissioning

21. The Customer will be invoiced the following fee each time it requests the decommissioning of a Shared TV Channel Interface on an existing OAL (redundant or not):

	Price
Shared TV Channel Interface Decommissioning Fee	€650,29

## 2.5 Dedicated Capacity



together  
with



## 2.5.1 Onetime Fees

### 2.5.1.1 Initial Dedicated Capacity Set-up

22. The Customer will be invoiced the following fee at the initial set-up of Multicast when it request the set-up of the Ordered Dedicated Capacity.

	<b>Price</b>
Dedicated Capacity Set-up Fee	€6132,71

### 2.5.1.2 Dedicated Capacity Increase

23. After the initial set-up the Customer can request an increase of its Ordered Dedicated Capacity upon conditions specified in Anne 3 –Planning and Operations. Each time the Customer requests an increase of Dedicated Capacity it will be invoiced the following fee:

	<b>Price</b>
Dedicated Capacity Increase Fee	€281,19

### 2.5.1.3 Dedicated Capacity Decrease

24. After the initial set-up the Customer can request a decrease of its Ordered Dedicated Capacity upon conditions specified in Anne 3 –Planning and Operations. Each time the Customer requests a decrease of Dedicated Capacity it will be invoiced the following fee:

	<b>Price</b>
Dedicated Capacity Increase Fee	€281,19

### 2.5.1.4 Modification of Dedicated Streams Bandwidth Configuration

25. The Customer will be invoiced the following fee each time it requests a modification of Dedicated Streams Bandwidth Configuration:



together  
with



	<b>Price</b>
Modification of Dedicated Streams Bandwidth Fee	€6054,10

### 2.5.2 Dedicated Capacity Decommissioning

26. The Customer will be invoiced the following fee each time it requests the decommissioning of Dedicated Capacity:

	<b>Price</b>
Dedicated Capacity Decommissioning Fee	€5821,19

### 2.5.3 Monthly Ordered Dedicated Capacity Recurring fee

27. The Customer will be invoiced on a monthly basis the following price per Kbps of Ordered Dedicated Capacity

	<b>Price</b>
Monthly Ordered Dedicated Capacity Recurring Fee per Kbps	€0,64/Kbps

## 2.6 Wrongful repair request

28. In case of wrongful repair request by a Customer, as defined in section 8. 8 (“Wrongful Repair Requests”) of Annex 4 (Planning and Operations), Belgacom will invoice this Customer a fee of 220 Euro.

29. Belgacom will provide the following information to the Customer: the ticket number, the date and hour of opening and closing of the ticket, the identification number (e.g. directory numbers) and the cause of the wrongful repair.

## 2.7 SLA documented reports

46 Belgacom is entitled to invoice the Customer for the production of the SLA documented reports described in the Annex 5, Basic SLA, section 7 “Documented reports”. The unit price per report amounts 25,14 €.

## 3 Billing

### 3.1 Preliminary

- 47 Parties are defined in the present document as Belgacom a telecommunication operator in Belgium and Customer, an undertaking authorized to practice the activities covered by this agreement under the Belgian regulatory framework.
- 48 The Belgacom billing process is based on a number of steps in which the two Parties have specific responsibilities. In order to implement this process, both Parties need to put in place (a) system(s) that will be used for the purposes of accounting and billing.
- 49 For each Multicast product, Belgacom will invoice Customer accordingly
- 50 Belgacom shall record, store and process the Billing Data in accordance with Section 2 of this Document.
- 51 The “Billing Data” is the data that is necessary to ascertain the charges payable by Customer under the Agreement. The Billing Data is recorded via the Billing System as described in Section 2.2 of this Document.
- 52 All information related to the Billing procedures between Belgacom and Customer is covered by the obligation of confidentiality set out in the Agreement. Specifically, such information will be kept strictly confidential by the Parties and will only be used for the purposes of accounting, and invoicing between the Parties and will only be disclosed between the Parties, or as legally required or in the framework of formal dispute procedures. Belgacom will be under no obligation to provide to Customer direct access to its Billing system nor to any other system or facility generating the Billing Data.
- 53 Belgacom reserves the right to modify the layout and the presentation of the invoice to the Customer.

### 3.2 Recording and storage of billing data

- 54 For each service chargeable under the Agreement, Belgacom shall record via its Billing System at least the following Billing Data:
  - Product/service ID;
  - Type of request;
  - Subscription date;
  - End of month of Subscription date;
  - Customer ID;
  - Account ID;
- 55 The general list of billing data indicated above is not exhaustive. Pricing is set in the Section 1 of this Annex.
- 56 Billing Data shall be stored for 60 days after the due date of the related invoice. In case of a dispute on the Billing Data, Belgacom will use all reasonable effort to keep the storage of the concerned Billing Data. The storage of these detailed Billing Data shall be limited to the disputed amount of Billing Data.

### 3.3 Confirmation of charging principles

- 57 All charges payable under this Agreement shall be calculated in accordance with the rules set out in the relevant provisions of this Agreement and its Annexes.
- 58 For internal purpose, Belgacom will use 6 decimals in Euro. The use of decimals is set as follows:
- Per line items up to 4 decimals can be used in Euro.
  - The revenues, VAT and the totals use decimals in Euro.
- 59 In case of electronic billing only two decimals in Euro will be used.
- 60 All the non-recurring charges will be mentioned in the Invoice of the Billing Period covering the Bringing Into Service Date.
- 61 The recurring charges for the product fees will be mentioned in the Invoice of the Billing Period which the Bringing In Service Date encompasses. The Charges will be calculated on the proportion of the Billing Period in which the product and service fee were operational
- 62 Customer amount of charges will be divided in the groups of one-time fees and recurring fees for the services described in the pricelist of this offer (Section 1 of this Annex)



together  
with



## 3.4 Invoices

- 63 Multicast Services/Products defined on a per user basis will be invoiced as per the WBA VDSL2 billing principles further specified in the WBA VDSL2 Offer – Anne 6. The Multicast Services/products considered as per user basis and defined in previous section are listed below:
- Activation/Deactivation fee of Multicast on a WBA VDSL2 User line
  - Monthly Multicast Recurring Fee per User Line
- 64 All other Multicast Services/Products as defined in the list below will be invoiced according to the specifications described in this chapter. The Multicast services addressed by the following specifications are listed below:
- Encryption Key Interface Set-up Fee
  - Shared TV Channel Activation Fee
  - Monthly Radio Shared Channel Recurring Fee
  - Monthly SD Shared Channel Recurring Fee
  - Monthly HD Shared Channel Recurring Fee
  - Shared TV Channel Interface Set-up Fee
  - Dedicated Capacity Set-up Fee
  - Modification of Dedicated Streams Bandwidth Fee
  - Monthly Dedicated Capacity Recurring Fee
- 65 For each Billing Period, Belgacom shall provide to Customer the Invoice described hereafter. The Invoice will be established in accordance with the following rules:
- Invoice Details: the Invoice will list all the services that are provided by Belgacom to the Customer.
  - The above-mentioned Invoice will be transmitted either via ordinary mail, either via email or via CertiOne to the representatives or departments of Customer as listed in the confirmation letter for which a template is available upon request.
- 66 Any invoice or credit note transmitted by Belgacom will contain the following information, in addition to any legally required mentions and information:
- relevant Billing Period;
  - total net amount in Euro;
  - due VAT amount;
  - total amount due in Euro (including VAT);
  - Due Date.
- 67 Belgacom shall use its best endeavours to issue invoices as of the start of the applicable Billing Period. Though, in respect of the development of billing systems by both Parties and the sending of invoices, Belgacom cannot ensure that the invoicing for the products and services provided will be performed within specific delays. Delays in the production of invoices can occur under these circumstances following notification by the Billing Party. Neither party may construe any late billing by the other party as a renunciation to its right to payment of the said bills.
- 68 Notwithstanding the foregoing, if an adjustment is required following a change in the referred Price List, a pending Dispute (for which the appropriate Dispute resolution mechanisms have been timely activated in accordance with this Agreement) or the outcome of commercial negotiations having a retroactive effect, the amount of such adjustment shall be established and Belgacom shall issue an invoice or a credit note as the case may be, within 30 days from the date of the relevant adjustment.
- 69 All changes to amounts invoiced in accordance with this Section 4 will be effected through credit notes or additional invoices.

## 3.5 Payment

- 70 All charges due by Customer to Belgacom under the Agreement shall be paid within 30 Calendar Days after issuance of the invoice (the “Due Date”).
- 71 If Customer has sent to Belgacom a Notice of Dispute related to an amount invoiced by Belgacom and if such Dispute has not been resolved by the Due Date the disputed amount may be withheld until the dispute is resolved provided that the remaining balance is payable on the Due Date.
- 72 Credit notes will be set off against any payments due of the next invoice and are refundable when there are no outstanding invoices.
- 73 If payment is not received by Belgacom on or before the Due Date, Belgacom will be entitled to an interest calculated on the basis of the legal interest rate + 2 percent points on the unpaid balance for late payment interests, administrative and recovery costs, but is only due if the dispute has been resolved in favour of Belgacom. This interest shall accrue from the Due Date until the date of payment in full of the amount to be paid. Such interest shall accrue day by day and shall not be compounded. In the event that a Dispute resolution procedure has been initiated by Belgacom as provided by the Agreement (including Section 6 of this Document), this interest shall be limited to the legal interest rate.
- 74 Value Added Tax as well as any other applicable taxes, if any, shall be added to all or any part of the charges due under this Agreement and shall be paid by the Customer responsible for making such payment.
- 75 Any payments under this Agreement will be made in Euro and will be made by bank transfer on the bank accounts mentioned in the Invoice. Payment costs are borne by the Customer. Costs of credit notes are borne by Belgacom.

## 3.6 Disputes

- 76 The Parties shall use their reasonable endeavours to resolve, pursuant to this Section 6 disputes related to the calculation and settlement of the charges invoiced or to be invoiced pursuant to this Document. Notwithstanding the foregoing, either Party will be allowed to trigger at any time the dispute resolution procedure provided under the main body of the Agreement provided that such Party reasonably believes that the Dispute at stake involves aspects of the Parties’ rights and obligations broader than the mere calculation and settlement of charges pursuant to this Document. The fact that a Dispute involves aspects broader than the mere calculation and settlement of charges pursuant to this Document will not release the Disputing Party from its obligation to pay any undisputed amount pursuant to Section 2.5.2.
- 77 Any Dispute under this Section 2.6 will be triggered by a Notice of Dispute sent by registered letter by the Customer to Belgacom before the Due Date. Such Notice of Dispute will indicate the disputed amounts, as well as a summary of the grounds for the Dispute and the position of the Disputing Party. Any amount invoiced under the Agreement will be deemed accepted unless a Notice of Dispute has been sent in accordance with above.
- 78 Upon receipt of the Notice of Dispute, the Parties shall exchange by ordinary mail any information necessary or useful for solving the Dispute.
- 79 Within 15 Working Days from the date of the Notice of Dispute, Belgacom will provide, by registered mail, an answer (“Notice of Reply”) to the Customer. If Belgacom does not accept some or all the arguments of the Customer, the Notice of Reply will contain a justified reply to the arguments of the Customer. If Belgacom accepts all or some arguments of the Customer, Belgacom will, together with the Notice of Reply, issue a credit note for the relevant amount.
- 80 If, within 15 Working Days from the receipt of the Notice of Reply, the Customer confirms its position in writing by registered letter, the Parties will escalate the Dispute within their respective organization as provided under Section 2.6.6. If the Customer fails to confirm its position within 15 Working Days, from the date of the Notice

of Reply, any outstanding amounts will be paid promptly and without delay and the Dispute will be deemed settled.

- 81 If the Parties have been unable to settle the Dispute as provided under the foregoing provisions, they will refer the matter to Implementation Committee, which, if deemed necessary by either Party, will be organized for this specific purpose. If after such meeting, the Dispute remains, the Parties will follow such additional steps in the escalation procedure as provided in the main body of the Agreement, or, if requested by either Party, the Dispute will be submitted to a certified accountant to be either jointly appointed by the Parties, or, failing agreement between the Parties in this respect, to be appointed by “Belgisch Instituut voor Bedrijfsrevisoren”/”Institut Belge des Réviseurs d’Enterprise”. This certified accountant will investigate and determine a solution for the Dispute, acting as an expert and not as an arbitrator. Unless there is evidence of a manifest error, decision of the certified accountant will be final in respect of those elements covered by the Dispute referred to him/her and will be binding on the Parties. The Parties will co-operate with this investigation. The costs of the certified accountant will be borne as determined by him/her in proportion to the outcome of the Dispute. Prior to undertaking his/her mission, the certified accountant will provide the Parties with an estimate of the relevant fees and costs. Upon final settlement of the Dispute, any necessary credit note will be issued and any outstanding amount will be paid promptly and without delay.

Wholesale Multicast

# Annex 6: Prepayment Terms & Conditions

Created on: 06 March 2012

belgacom



## Prepayment Terms and Conditions

1. Belgacom will send on a monthly basis a pre-invoice at the latest on the 2nd working day after the starting of the month preceeding the considered billing month. For Customers that are in service, the first pre-invoice shall be based on the average of the invoices for Services issued by Belgacom during the last three months. For Customers not yet in service and concluding a new Contract, the first pre-invoice shall be based on the valuation of the average of the invoices for Services to be issued by Belgacom within the first three months of services.
2. The amount of the pre-invoice shall be adapted on a quarterly basis, i.e. increased or lowered as the case may be, based on the amounts due by the Customer for the Services provided under the Contract during the previous quarter.
3. The Customer agrees to pay the amount of the pre-invoice at the latest the 10th calendar day from the date of the pre-invoice.
4. The amount of the pre-invoice shall be paid on a specific account number to be communicated. The interests generated by the amount of the pre-invoice paid on this account during the period starting from the date the pre-invoice is paid until the date the final invoice is paid shall be accrued to the Customer.
5. Within 15 calendar days after sending the final invoice, Belgacom will send a credit note regarding the pre-invoice.
6. If for the same month the amount of the pre-invoice is higher than the amount of the final invoices, Belgacom shall reimburse the balance.
7. If for the same month the amount of the pre-invoice is lower than the amount of the final invoices, the Customer will pay the surplus.
8. Within 15 days following the final invoice, the Customer will make the payment by wire transfer. If payment is not received by Belgacom on or before this due date, Belgacom will be entitled to an interest calculated on the basis of the legal interest rate + 2 percent points on the unpaid balance for late payment interest, administrative and recovery costs. For disputed amounts, this interest is only due if the dispute has been resolved in favour of Belgacom.
9. If the Customer disagrees with an invoice received from Belgacom, it must notify in writing Belgacom thereof before the due date of such invoice in accordance with the relevant provisions of the Contract.
10. Without prejudice to other legal or contractual remedies and notwithstanding anything to the contrary in the Agreement, in the event the Customer fails to pay in due time any undisputed amount due under the present Prepayment terms and conditions, Belgacom shall be entitled to:
  - Suspension of any SLA obligation;
  - Refusal in writing of any new Order;
  - Suspension of the existing Services in accordance with article 82 of the Annex 1 – General Terms and Conditions.