



**INSTITUT BELGE DES SERVICES POSTAUX ET DES
TELECOMMUNICATIONS**

**DECISION DU CONSEIL DE L'IBPT DU 12 JANVIER 2010
CONCERNANT LA CONFORMITE DU SYSTEME DE
COMPTABILISATION DES COUTS DE BELGACOM POUR 2008**

Version publique

Table des matières

1 Objet	3
2 Rétroactes	3
3 Bases juridiques	4
4 Confidentialité	4
5 Constatations de l'IBPT	4
6 Décision	6
7 Voies de recours.....	6
Annexe: conclusions du réviseur d'entreprises.....	7

1 OBJET

La présente décision a pour objectif de publier une attestation de conformité du système de comptabilisation des coûts de Belgacom, conformément aux articles 62 § 4 et 64 § 2 de la loi du 13 juin 2005 relative aux communications électroniques (ci-après la loi du 13.06.2005).

2 RETROACTES

Par décision du Conseil de l'IBPT, la mise en place d'un système de comptabilisation des coûts a été rendue obligatoire pour Belgacom en relation avec les marchés suivants :

Marchés pertinents¹		Décisions de l'IBPT
1	Accès au réseau téléphonique public en position déterminée pour la clientèle résidentielle	Décision du 19 juin 2006
2	Accès au réseau téléphonique public en position déterminée pour la clientèle non-résidentielle	Décision du 19 juin 2006
3	Services téléphoniques nationaux pour la clientèle résidentielle	Décision du 6 novembre 2008
5	Services téléphoniques nationaux pour la clientèle non-résidentielle	Décision du 6 novembre 2008
7	Ensemble minimal de lignes louées	Décision du 17 janvier 2007 ²
8	Services de départ d'appel	Décision du 11 août 2006
9	Services de terminaison d'appel	Décision du 11 août 2006
10	Services de transit	Décision du 11 août 2006
11	Fourniture en gros d'accès dégroupé	Décision du 10 janvier 2008 ³
12	Fourniture en gros d'accès à large bande	Décision du 10 janvier 2008 ⁴
13	Fourniture en gros de segments terminaux de lignes louées	Décision du 17 janvier 2007 ⁵

Le 6 mai 2009, Belgacom a transmis à l'IBPT le cahier des charges définissant la mission du réviseur d'entreprises chargé d'effectuer l'audit du système de comptabilisation des coûts pour l'année 2008.

Le 1^{er} octobre 2009, Belgacom a communiqué à l'Institut la documentation fonctionnelle relative au périmètre des coûts, au modèle Activity Based Costing 2008 et au modèle réseau et IT 2008.

Le 30 octobre 2009, Belgacom a communiqué à l'Institut la description du système de comptabilisation des coûts 2008 destinée à être rendue publique.

Le 10 novembre 2009, Belgacom a communiqué à l'Institut les conclusions du réviseur d'entreprises ainsi que le rapport des travaux d'audit dans son intégralité.

Le 9 décembre 2009, un projet de décision a été communiqué à Belgacom pour consultation.

Le 18 décembre 2009, Belgacom a communiqué ses commentaires sur le projet de décision.

¹ Numérotés en concordance avec la Recommandation de la Commission du 11 février 2003 concernant les marchés pertinents de produits et de services dans le secteur des communications électroniques susceptibles d'être soumis à une réglementation ex ante conformément à la directive 2002/21/CE du Parlement européen et du Conseil relative à un cadre réglementaire commun pour les réseaux et services de communications électroniques.

² Compte tenu du fait qu'une décision de réfection est en préparation.

³ Compte tenu de la décision de réfection du 2 septembre 2009.

⁴ Compte tenu de la décision de réfection du 2 septembre 2009.

⁵ Compte tenu du fait qu'une décision de réfection est en préparation.

3 BASES JURIDIQUES

L'article 62 § 3 de la loi du 13 juin 2005 prévoit que « lorsque la mise en place d'un système de comptabilisation des coûts est rendue obligatoire, l'Institut publie une description de ce système qui comprend au moins les principales catégories regroupant les coûts et les règles appliquées en matière de comptabilisation des coûts. »

L'article 62 § 4 de la même loi prévoit que « lorsque le système de comptabilisation des coûts appliqué par l'Institut le rend nécessaire, le respect du système de comptabilisation des coûts est vérifié, aux frais de l'opérateur, par un réviseur d'entreprises agréé désigné par cet opérateur. L'Institut est tenu de publier chaque année une déclaration relative au respect du système, sur la base des conclusions du rapport du réviseur d'entreprises. »⁶

L'article 64 § 2 de la même loi prévoit qu'un réviseur d'entreprises agréé désigné par l'opérateur vérifie, aux frais de cet opérateur, le respect des systèmes de comptabilisation des coûts, lorsque l'Institut souhaite contrôler les tarifs des utilisateurs finaux conformément [à l'article 64 § 1er] et que l'Institut détermine les systèmes de comptabilisation de coûts nécessaires et appropriés que l'opérateur visé applique. L'Institut est tenu de publier chaque année une attestation de conformité de ces systèmes.

La décision de l'IBPT du 22 août 2007⁷ a déterminé les conditions que Belgacom doit respecter dans la mise en oeuvre de son système de comptabilisation des coûts. Ces conditions portent sur les principes généraux, la qualité de l'information, les règles d'allocation et d'évaluation, la documentation, la description et le contrôle du système de comptabilisation des coûts, ainsi que sur les délais à respecter.

4 CONFIDENTIALITE

A l'occasion de la consultation précédent l'adoption de la décision concernant la conformité du système de comptabilisation des coûts de Belgacom pour 2007, il est apparu que l'auditeur ne se conformerait pas aux normes d'audit en vigueur et aux recommandations de l'Institut des réviseurs d'entreprises s'il devait mentionner dans son opinion des risques non matériels. Dans la présente décision, l'Institut résume dès lors lui-même les principales remarques développées dans le rapport des travaux d'audit. Le cas échéant, ce résumé est traité comme confidentiel. Les passages remplacés par la mention [confidentiel] ne remettent nullement en cause les conclusions de l'IBPT.

5 CONSTATATIONS DE L'IBPT

L'IBPT a vérifié que la mission confiée par Belgacom au réviseur d'entreprises était conforme aux prescriptions de la section 8.2 de la décision de l'IBPT du 22 août 2007, à savoir : vérifier la pertinence du périmètre des coûts et des recettes, vérifier le respect des exigences de base, vérifier l'application des règles d'allocation et d'évaluation et présenter à l'IBPT un rapport sur l'exécution de sa mission.

L'IBPT a constaté que la réalisation de l'audit avait été confiée par Belgacom à la société Deloitte Bedrijfsrevisoren / Reviseurs d'entreprises, enregistrée auprès de l'Institut des réviseurs d'entreprises sous le numéro B00025.

L'IBPT a constaté que le contenu de la documentation fonctionnelle et de la description publique du système de comptabilisation des coûts était conforme aux prescriptions des sections 6.3 (Règles à suivre et documentation à préparer) et 7 (Description du système de comptabilisation des coûts) de la décision de l'IBPT du 22 août 2007.

Conformément à la décision du 22 août 2007 (section 8.2.3), le réviseur d'entreprises doit vérifier que les règles d'allocations et de réévaluation appliquées correspondent bien à la documentation préparée

⁶ Tel que modifié par l'article 21 de la loi du 18 mai 2009 portant des dispositions diverses en matière de communications électroniques (M.B. 04/06/2009).

⁷ Décision du Conseil de l'IBPT du 22 août 2007 concernant la mise en oeuvre de l'obligation pour Belgacom de mettre en place un système de comptabilisation des coûts.

par Belgacom et à la description du système de comptabilisation des coûts. Le réviseur d'entreprises a exécuté différentes procédures analytiques visant l'identification et l'analyse des variations significatives dans le périmètre des coûts entre 2007 et 2008, la vérification des modifications des méthodes de réévaluation des actifs entre 2007 et 2008 et l'identification et l'analyse des variations de coûts entre 2007 et 2008 aux différentes étapes d'allocation des modèles. La portée de ces travaux d'audit est conforme à la décision du 22 août 2007, laquelle prévoit qu'un audit approfondi peut être effectué une année sur deux, en alternance avec un audit plus limité, concentré sur les changements de méthodologies et les variations de résultats.

||[confidentiel].

Le réviseur d'entreprises a formulé des remarques concernant [confidentiel].

Sur base de l'opinion du réviseur d'entreprises, l'IBPT conclut qu'aucun fait ne porte à croire que les modèles d'allocation et de comptabilisation des coûts relatifs à l'année comptable 2008, ne seraient pas établis conformément aux dispositions légales et réglementaires pertinentes et à la décision du 22 août 2007.

6 DECISION

Après avoir dûment considéré les points de vue des parties concernées, tels que ceux-ci sont exprimés dans leur correspondance ou lors de réunions d'une part, et d'autre part, les objectifs généraux du cadre réglementaire en matière de promotion de la concurrence, d'efficacité économique et de défense des intérêts des consommateurs, l'Institut adopte la décision suivante :

1. Le système de comptabilisation des coûts 2008 de la société Belgacom répond aux prescriptions de la décision de l'IBPT du 22 août 2007.
2. Les conclusions du réviseur d'entreprises ayant procédé à l'audit du système de comptabilisation des coûts de Belgacom pour l'année 2008 sont publiées en annexe à la présente décision.
3. La description du système de comptabilisation des coûts de Belgacom pour l'année 2008 est publiée sur le site Internet de l'Institut.

7 VOIES DE RECOURS

Conformément à la loi du 17 janvier 2003 concernant les recours et le traitement des litiges à l'occasion de la loi du 17 janvier 2003 relative au statut du régulateur des secteurs des postes et télécommunications belges, vous avez la possibilité d'interjeter appel de cette décision devant la cour d'appel de Bruxelles, Place Poelaert 1, B-1000 Bruxelles. Les recours sont formés, à peine de nullité prononcée d'office, par requête signée et déposée au greffe de la cour d'appel de Bruxelles dans un délai de soixante jours à partir de la notification de la décision ou à défaut de notification, après la publication de la décision ou à défaut de publication, après la prise de connaissance de la décision.

La requête est déposée au greffe de la juridiction d'appel en autant d'exemplaires qu'il y a de parties en cause. La requête contient, à peine de nullité, les indications de l'article 2, §2 de la loi du 17 janvier 2003 concernant les recours et le traitement des litiges à l'occasion de la loi du 17 janvier 2003 relative au statut du régulateur des secteurs des postes et télécommunications belges.

C. Cuveliez
Membre du Conseil

A. Desmedt
Membre du Conseil

C. Rutten
Membre du Conseil

L. Hindryckx
Président du Conseil

ANNEXE: CONCLUSIONS DU REVISEUR D'ENTREPRISES

A l'attention de
Monsieur Steven Tas,
Vice President Group Regulatory
Bld du Roi Albert II, 27,
1030 Bruxelles

Monsieur,

Conformément à la législation en vigueur et en accord avec l'appel d'offre émis par Belgacom en date du 16 juin 2009, nous avons effectué une revue limitée des modèles d'allocation PPP, ABC et IT/N de comptabilisation des coûts courants relatifs à l'année comptable clôturée le 31 décembre 2008 tel que décrits et identifiés dans notre rapport détaillé de revue limitée à usage strictement confidentiel. Les modèles d'allocation concernés sont basés sur les comptes annuels clôturés le 31 décembre 2008. Ceux-ci ont fait l'objet d'un contrôle par le commissaire Ernst and Young qui a émis un rapport sans réserves sur les comptes annuels.

La mission de la revue limitée a pour objectif d'assister Belgacom dans l'accomplissement des obligations de communication de Belgacom S.A. à l'égard de l'IBPT (Institut Belge des services postaux et des télécommunications).

L'établissement des modèles d'allocation PPP, ABC et IT/N de comptabilisation des coûts courants relève de la responsabilité du département Regulatory de Belgacom. Les modèles d'allocation PPP, ABC et IT/N doivent être conçus en conformité avec la loi du 13 juin 2005 relative aux communications électroniques, la décision du 22 août 2007 du conseil de l'IBPT concernant la mise en œuvre de l'obligation pour Belgacom de mettre en place un système de comptabilisation des coûts, les dernières décisions tarifaires relatives aux offres de référence et la Législation Européenne et en particulier la directive 2002/19/CE du parlement européen et du conseil du 7 mars 2002 relative à l'accès aux réseaux de communications électroniques et aux ressources associées, ainsi qu'à leur interconnexion (directive accès), et enfin la recommandation du 19 Septembre 2005 de la Commission Européenne concernant la séparation comptable et les systèmes de comptabilisation des coûts au titre du cadre réglementaire pour les communications électroniques. En outre de cette responsabilité de conception, le département Regulatory de Belgacom est aussi responsable de la mise en œuvre de ces modèles afin que la répartition des coûts courants ne comporte pas d'anomalies significatives, que celles-ci résultent de fraudes, d'erreurs ou de la détermination de clés d'allocation inappropriées au regard des circonstances.

Notre revue a été réalisée conformément aux recommandations en matière de revue limitée applicables en Belgique telles qu'édictées par l'Institut des Réviseurs d'Entreprises. Une revue limitée consiste principalement en la discussion de la conception des modèles d'allocation PPP, ABC et IT/N et de leur mise en œuvre avec leurs responsables ainsi que l'exécution de procédures analytiques sur l'allocation des coûts courants réalisée sur base de ces modèles. L'étendue de ces travaux est moins importante que celle qui résulte d'un contrôle complet, exécuté suivant les normes de révision édictées par l'Institut des Réviseurs d'Entreprises. De ce fait, si nous avions procédé à une revue complète des modèles d'allocation PPP, ABC et IT/N les conclusions auraient pu être différentes.

La revue s'est limitée aux procédures suivantes:

- l'identification et analyse des variations significatives du périmètre des coûts entre 2007 et 2008 ;
- la vérification des modifications de méthode de réévaluation des actifs mise en œuvre dans le cadre de l'allocation des coûts courants de 2007 et de 2008 ;
- et l'identification et l'analyse des variances de coûts entre 2007 et 2008 à chaque étape d'allocation des modèles IT/N, ABC et PPP.

Les origines de chaque variance ont été expliquées en investiguant si elles provenaient d'un changement des clés d'allocation suite à une réorganisation ou un changement de méthodologie, d'une variation de la quantité des clés d'allocation existantes ou d'une modification de la source de coût. La pertinence et la consistance de chacune de ces explications ont été vérifiées.

Suite aux analyses susvisées, nous avons pu identifier deux principales sources de variation du coût total des produits, à savoir :

- la méthode de réévaluation des coûts pour les réseaux data (ATM) suite à l'alignement au modèle BROBA de l'IBPT;
- la revue de la clé d'allocation des coûts du réseau cuivre dans le modèle PPP a causé un transfert de ces coûts des technologies PSTN vers les technologies ADSL.

Sur base de notre revue limitée, aucun fait n'a été porté à notre attention qui nous porterait à croire que les modèles d'allocation PPP, ABC et IT/N de comptabilisation des coûts courants relatifs à l'année comptable clôturée le 31 décembre 2008 ne sont pas établis conformément aux dispositions légales et réglementaires susmentionnées.

Les variances ont été justifiées par Belgacom et n'impactent pas la logique opérationnelle et technique des différents produits et activités.

Diegem, le 6 novembre 2009

Le Réviseur d'Entreprises

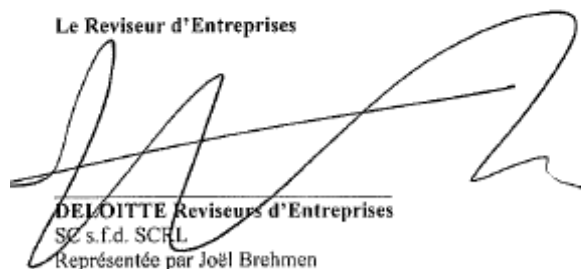

DELOITTE Réviseurs d'Entreprises
SC s.f.d. SCRL
Représentée par Joël Brehmen

*Cette opinion ne peut être traduite sans l'accord et la révision de la traduction de Deloitte

The Belgacom S.A. cost accounting system

General Description

Financial year 2008

TABLE OF CONTENT

<u>1</u>	<u>DESCRIPTION GENERALE</u>	<u>7</u>
<u>2</u>	<u>PERIMETRE DES COUTS INCLUS DANS LE MODELE</u>	<u>9</u>
2.1	COUTS INCLUS DANS LE MODELE	9
2.2	COUTS EXCLUS DU MODELE	9
<u>3</u>	<u>REGROUPEMENTS DES DONNEES COMPTABLES</u>	<u>10</u>
<u>4</u>	<u>REPARTITION DU PERIMETRE DES COUTS ENTRE LE MODULE ABC ET LE MODULE NETWORK / IT</u>	<u>11</u>
<u>5</u>	<u>CHANGEMENTS ORGANISATIONNELS</u>	<u>11</u>
<u>6</u>	<u>THE ABC COST MODEL</u>	<u>14</u>
6.1	INTRODUCTION	14
6.2	DETAILED DESCRIPTION OF THE ALLOCATION STEPS	14
6.2.1	<i>STEP 2: ALLOCATING COSTS DIRECTLY TO THE PRODUCTS</i>	15
6.2.1.1	Material out of stock	15
6.2.1.2	Services and other goods	15
6.2.1.3	Remuneration, social security costs and pensions.	15
6.2.1.4	Depreciation, write-offs, provisions for liabilities and WACC	16
6.2.2	<i>STEP 3: ALLOCATING INDIRECT COSTS TO ACTIVITIES</i>	16
6.2.3	<i>STEP 4: ALLOCATION OF THE SUPPORT COSTS</i>	17
6.2.3.1	Allocation of the IT activities (process 7)	17
6.2.3.2	Allocation of the logistics activities (process 6)	17
6.2.3.2.1	<i>Allocation of building costs</i>	18
6.2.3.2.2	<i>Allocation of fleet costs</i>	18
6.2.3.2.3	<i>Allocation of other facilities costs</i>	18
6.2.3.2.4	<i>Allocation of the supply chain activities costs</i>	19
6.2.4	<i>STEP 5: ALLOCATION OF THE PRIMARY AND MANAGEMENT ACTIVITIES TO THE PRODUCTS</i>	19
6.2.4.1.1	Allocation of the primary activities.	19
6.2.4.1.1	Process 1: Strategy, Product and Market Management.	20
6.2.4.1.2	Process 2: Fulfilment: activities going from sales, order handling to installation.	23

6.2.4.1.3 Process 3: Service Assurance: fault handling and repairing	29
6.2.4.1.4 Process 4: Billing and Collection	31
6.2.4.1.5 Process 5: Network Build and Maintenance	34
6.2.4.2 Allocation of the management activities.	34
6.2.4.2.1 Process 8: HR Management	35
6.2.4.2.2 Process 9: Financial Management	35
6.2.4.2.3 Process 10: Administration & General Support	35
6.2.4.2.4 Process 11: Manage improvement and change	35
6.2.5 STEP 6: ALLOCATION OF THE IT COSTS	35

7 NETWORK & IT COST MODELS **36**

7.1 INTRODUCTION	36
7.2 COST BASE IN THE NETWORK & IT COST MODEL	37
7.2.1 COST CATEGORIES	37
7.2.1.1 Direct costs	37
7.2.1.2 Indirect costs	39
7.3 METHODS USED TO REEVALUATE THE NETWORK ASSETS	40
7.3.1 PRICE INDEXATION	41
7.3.2 INVENTORY	41
7.3.3 KEEP AS IT IS.	41
7.3.4 INDEX BASED ON A FIXED PPC	41
7.3.5 TAM: TILTED ANNUITY METHOD	42
7.3.5.1 Theory	42
7.3.6 REGULATED COST PRICE BASED ASSET VALUATION.	43
7.3.6.1 CAPEX Costing of the VP switching component	43
7.3.6.2 CAPEX Costing of the ATM access component .	44

8 NETWORK & IT FULLY ALLOCATED COST TOP DOWN MODEL **45**

8.1 INTRODUCTION	45
8.2 BASIC COMPONENTS OF THE MODEL	46
8.2.1 COST SOURCES	46
8.2.1.1 CAPEX	46
8.2.1.2 OPEX	46
8.2.2 COST COMPONENTS: DEFINITIONS	47
8.2.2.1 Cost Pools	47
8.2.2.2 Network elements	48
8.2.2.3 Network layer services	49
8.2.2.4 End user services	49
8.3 THE FULLY ALLOCATED COST MODEL (FAC)	50
8.3.1 NETWORK INFRASTRUCTURE COSTS	50
8.3.1.1 Cost Pools	51
8.3.1.2 Network elements	52
8.3.1.3 Network Layer Services	53
8.3.1.4 End User Services	55

9 THE NETWORK AND IT OPERATIONAL COST MODEL **57**

9.1	COST OBJECTS	57
9.2	COMMON OPEX ALLOCATION STREAM IT AND NETWORK	58
9.2.1	GL61 ACCOUNTS – SERVICES AND OTHER GOODS (SOG)	58
9.2.2	GL62 ACCOUNTS – WAGES COSTS	58
9.2.3	GL60 ACCOUNTS – MATERIAL OUT OF STOCK	59
9.2.4	ALLOCATION OF TEAMGROUPS TO ACTIVITIES	59
10	TOP DOWN COPPER ACCESS NETWORK MODEL	60
10.1	BASIC COMPONENTS OF THE MODEL	60
10.1.1	COST POOLS	60
10.1.1.1	Customer premises equipment	60
10.1.1.2	Copper plant	61
10.1.2	NETWORK ELEMENTS	61
10.1.2.1	Copper Drop Segment	62
10.1.2.2	Local Copper Cables	62
10.1.2.3	Copper Feeding, Distribution, Street Cabinet & MDF	62
10.1.2.4	NT1	62
11	TOP DOWN FIBRE INFRASTRUCTURE MODEL	63
11.1	INTRODUCTION	63
11.2	SPLIT OF THE TRENCHING AND THE DUCTS INVESTMENT COSTS.	63
11.3	SPLIT OF THE FIBRE CABLE INVESTMENT COSTS.	64
12	TOP DOWN BACKBONE MODEL	66
12.1	INTRODUCTION	66
12.2	BASIC COMPONENTS OF THE MODEL	67
12.2.1	NETWORK ELEMENTS	67
12.2.1.1	Type of network elements and location in the network	67
12.2.1.2	Network topology and equipment functionalities	68
12.2.2	NETWORK LAYER SERVICES	69
12.3	TRANSMISSION COST ALLOCATION	70
12.3.1	NETWORK ENTITIES DEFINITION	70
12.3.1.1	Line systems	70
12.3.1.2	Transmission systems and multiplexing hierarchy	71
12.3.1.3	WDM layer	71
12.3.1.4	Ring objects	72
12.3.2	ALLOCATION METHODS AND USED DRIVERS	73
12.3.2.1	Modular equipments	73
12.3.2.2	Meshed network	73
12.3.2.3	Fibre infrastructure and WDM network	73
12.4	CONCLUSION: THE BACKBONE COST STRUCTURE	74
13	TOP DOWN SWITCH MODEL	75

13.1	BASIC COMPONENTS OF THE MODEL	75
13.1.1	COST POOLS	75
13.1.1.1	Basic Switch Platform	75
13.1.1.2	IN Platform	79
13.1.1.3	Control and Supervision	80
13.1.1.4	Charging	80
13.1.1.5	Specific Equipment	81
13.1.2	NETWORK ELEMENTS	81
13.1.2.1	Basic Switch Platform	81
13.1.2.2	IN platform	81
13.1.2.3	Control and Supervision	82
13.1.2.4	Charging	83
13.1.2.5	Specific equipment	83
13.2	COST ALLOCATION	83
13.2.1	COST ALLOCATION FOR THE BASIC SWITCH PLATFORM	83
13.2.1.1	Customer access sensitive	83
13.2.1.2	Traffic sensitive	83
13.2.1.2.1	Routing factors	84
13.2.1.2.2	Traffic End User Services	84
13.2.2	COST ALLOCATION FOR THE IN PLATFORM	84
13.2.3	COST ALLOCATION FOR CONTROL & SUPERVISION	86
13.2.4	COST ALLOCATION FOR CHARGING	87
13.2.5	COST ALLOCATION FOR SPECIFIC SERVICES	87

14 TOP-DOWN DATA MODEL 88

14.1	INTRODUCTION	88
14.2	ATM DATA ALLOCATION STREAM	89
14.2.1	FROM ASSETS TO COST POOLS	89
14.2.2	ATM REGIONAL NETWORK AND ATM REGIONAL TRIBUTARIES (CP2-NLS3 ALLOCATION STEPS)	89
14.2.3	ATM BASED SERVICES AND CONSTITUTION OF MONITORING NETWORK DCN-SWIBEL (NLS3-NLS4 ALLOCATION STEP)	90
14.2.3.1	DATA Trunk ATM-DSLAM :	90
14.2.3.2	DATA Trunk ATM-ATM Express :	90
14.2.3.3	ATM Regional Transport	90
14.2.3.4	Swibel (NLS4 allocation level)	91
14.2.4	MONITORING THE NETWORK (NLS4-NLS5 ALLOCATION STEP)	91
14.2.5	BROBA, ACCESS TO INTERNET , ACCESS TO EXPLORE SERVICES (NLS5-NLS6 ALLOCATION STEP)	91
14.2.5.1	Swibel_transmission	91
14.2.5.2	Swibel_switching	91
14.2.5.3	xDSL_ATM_Regional_Transport	92
14.3	DATA ACCESS EQUIPMENT STREAM	92
14.3.1	FROM AC1/AC2 TO NLS4 : THE NETWORK ADSL/SDSL BITSTREAM SERVICE	92
14.3.2	FROM NLS4 TO NLS5 : SHIFT	92
14.3.3	FROM NLS5 TO NLS6 : ADSL/SDSL BITSTREAM FOR RETAIL AND WHOLESALE	92
14.3.4	FROM NLS6 TO EUS : RETAIL AND WHOLESALE ATM BASED SERVICES	92
14.4	DATA EDGE EQUIPMENT STREAM	93
14.5	COPPER LINE STREAM FOR DATA SERVICES	93

15 IT CAPEX COST ALLOCATION STREAM

95

1 Description générale

Le département REG¹ assure la préparation des comptes séparés et opère le modèle d'élaboration des coûts sous-jacent à la production des coûts séparés et utilisé dans différents autres dossiers réglementaires. Conformément aux recommandations de la Commission Européenne, la totalité des coûts issus de la comptabilité générale (statutaire) est prise en compte dans le cadre de l'élaboration des comptes séparés et du modèle de coûts sous-jacent, à l'exception des comptes 65, 67 et des coûts des autres comptes écartés du périmètre. Les coûts utilisés dans l'exercice de modélisation sont directement issus du système SAP qui administre la comptabilité générale de Belgacom S.A. Les comptes statutaires ont fait l'objet d'un audit statutaire en 2009 effectué par Ernst & Young, Réviseurs d'Entreprises. Le collège des réviseurs d'entreprises a émis une attestation sans réserve des comptes annuels.

La production des comptes séparés s'effectue au départ de l'agrégation de produits qui sont rattachés à l'un ou l'autre des quatre blocs requis : Réseau de transport, Réseau d'accès, Activités commerciales et Autres activités. Ensuite, en fonction des consommations réciproques de certains de ces produits par les blocs séparés, le département REG opère des transferts entre les blocs.

Les comptes séparés émanent de la consolidation des modules Network / IT et ABC du système de comptabilisation des coûts de Belgacom, incluant le périmètre issu de la comptabilité générale ainsi que le coût du capital repris dans ces deux modules.

Le schéma suivant représente la structure du système de comptabilisation des coûts et mentionne les modules principaux. L'entièreté des éléments de coûts présents dans les modules est intégrée dans un logiciel (INCA) qui en effectuant des tests de validations empêche toute possibilité de double comptage ou d'attribution multiple.

¹ REG: Group Regulatory Affairs

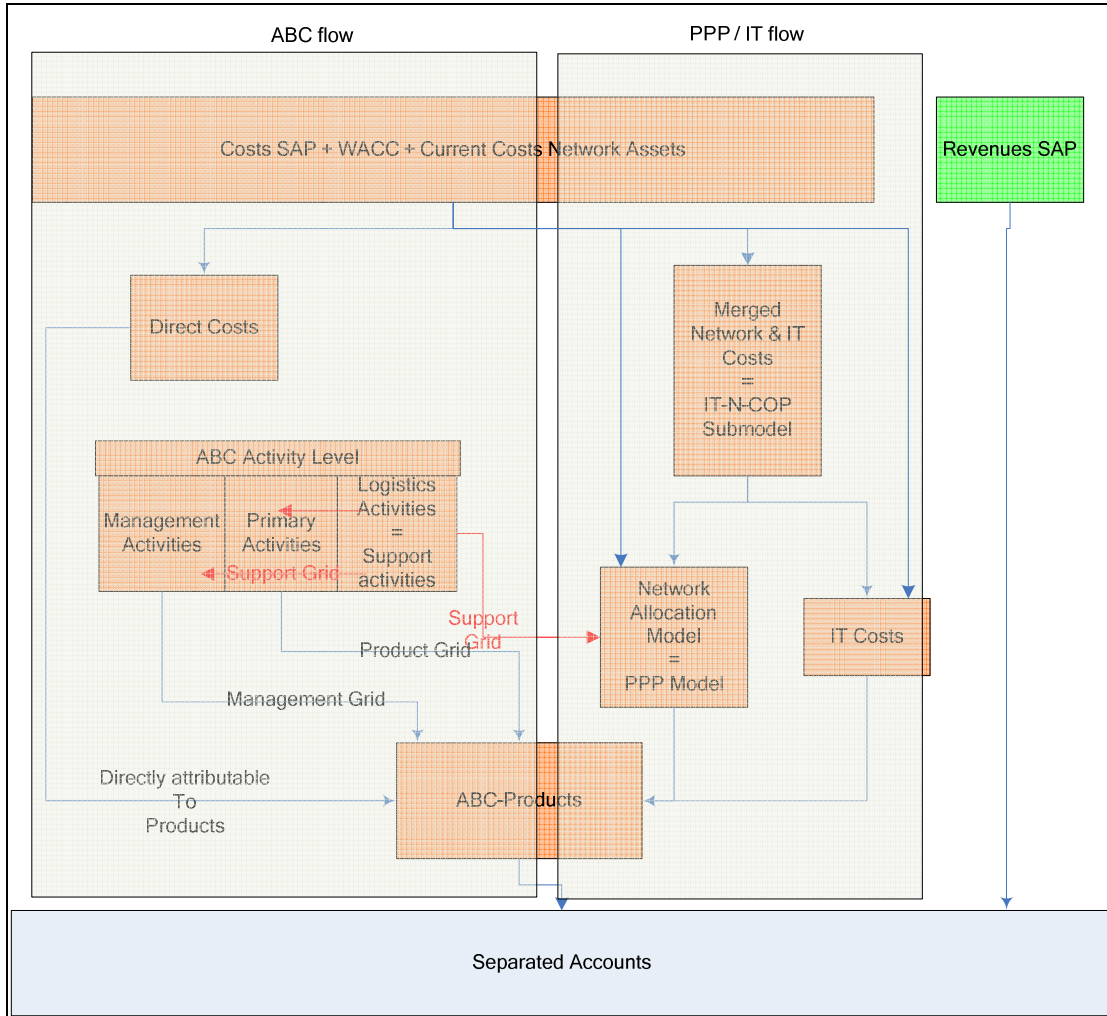

Figure 1 - Belgacom SA Cost Model

Le module ABC reprend les coûts commerciaux et les autres coûts directs ou indirects qui ne sont pas repris dans le module Network / IT.

Le module Network / IT, quant à lui, traite tous les coûts en matière de réseau et d'informatique, à l'exception de l'activité « End-User Support ».

Des ajustements liés au passage des coûts historiques aux coûts courants sont effectués pour les coûts de réseau et ont pour effet d'augmenter la base de coûts pris en compte dans la comptabilité séparée et le modèle de coûts sous-jacent.

Le département REG s'assure qu'il n'y a pas de double comptage entre les modules ABC et Network / IT et que les données issues du système SAP correspondent bien à celles qui approvisionnent les comptes séparés et le modèle de coûts.

Le modèle d'élaboration des coûts de revient par produit suit l'approche "top-down".

2 PERIMETRE DES COUTS INCLUS DANS LE MODELE

2.1 Coûts inclus dans le modèle

Les coûts inclus dans le modèle sont les comptes de charges opérationnelles, c'est à dire les comptes 60 à 64 de la comptabilité générale, ainsi qu'une partie des comptes 66 et 69.

Le compte 60 "achats de matériel" comprend principalement des achats de matériel télécom (modem ADSL, terminaux, câbles, cartes, mobiles, ...) et de fournitures (fax, ...) et des variations de stocks.

Le compte 61 "services et biens divers" comprend principalement les charges liées au trafic (notamment les redevances d'interconnexion) et les charges de maintenance, d'énergie, de locations, de publicité, de représentation, de consultants, de déplacements.

Le compte 62 correspond aux charges de personnel.

Le compte 63 correspond aux dotations aux amortissements, aux provisions et aux réductions de valeur.

Le compte 64 regroupe les autres charges opérationnelles, parmi lesquelles se retrouvent principalement les éléments suivants: abandons de créances, taxes locales et précompte immobilier.

Le compte 66 reprend le montant de charges exceptionnelles correspondant au montant PBS (Pension Back Service) accepté par l'IBPT dans le cadre de l'offre BRIO.

Le compte 69 reprend le montant d'affectations et prélèvements correspondant à la participation du personnel dans le bénéfice de l'exercice (bonus collectif).

Par ailleurs, le compte 72 – "Production immobilisée" vient diminuer la base des coûts pour annuler les charges liées à la production immobilisée et éviter un double comptage avec les charges d'amortissements correspondantes.

Au périmètre issu de la comptabilité générale s'ajoute le coût moyen pondéré du capital (WACC) de 11,20%.

2.2 Coûts exclus du modèle

Les autres charges sont exclues du modèle. Il s'agit des comptes 65 à 69 de la comptabilité générale, excepté une partie des comptes 66 et 69.

Certaines charges sont exclues car considérées comme n'ayant pas de lien de causalité avec les produits et les activités. C'est le cas des charges exceptionnelles qui n'ont pas été reprises dans l'offre BRIO (compte 66) et des charges fiscales (comptes 67).

D'autres charges sont exclues du fait qu'elles sont déjà prises en compte dans le coût moyen pondéré du capital. Il s'agit des charges financières (compte 65) et des charges de dividendes (compte 69).

3 REGROUPEMENTS DES DONNEES COMPTABLES

Belgacom enregistre les coûts d'une part sur un compte défini dans la comptabilité générale et d'autre part sur un centre de coûts défini dans la comptabilité analytique. Cette étape a pour objectif d'agréger ces données afin de simplifier la manipulation de ces données.

Deux types de regroupement sont effectués :

- celui des 513 comptes de la comptabilité générale en 156 cost pools et
- celui des 482 centres de coûts en 230 groupes de centres de coûts.

Un **cost pool** est un groupe de coûts qui ont des caractéristiques communes et sont issus de la même famille de nature de coûts.

Dans le cas de ressources matérielles, seront regroupés les coûts qui remplissent une fonction similaire.

Les coûts repris dans un même cost pool ont une relation de causalité identique avec les activités ou les produits auxquels ils peuvent être attribués, ils ont le même "resource driver".

Un **groupe de centres de coûts** regroupe des centres de coûts qui ont des caractéristiques communes et qui réalisent des activités similaires.

Ainsi, les combinaisons cost pool/groupe de centres de coûts forment des groupes de ressources. Ce sont ces groupes de ressources qui constituent la base de coûts du modèle, et plus particulièrement du module ABC.

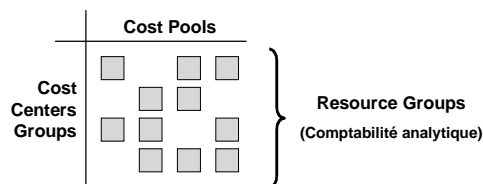

Fig. 1: Groupes de ressources

4 REPARTITION DU PERIMETRE DES COUTS ENTRE LE MODULE ABC ET LE MODULE NETWORK / IT

Le périmètre des coûts est réparti par le département REG entre les modules Network / IT et ABC en s'assurant que les données de coûts issues de SAP et traitées par les deux modules soient complètes et ne contiennent pas de doublons. Comme mentionné dans la description générale, le module Network / IT alloue tous les coûts et investissements en matière d'informatique (à l'exception de l'activité « End-User Support ») et de réseau alors que le module ABC alloue tous les autres coûts et investissements.

5 CHANGEMENTS ORGANISATIONNELS

In January 2008 a complete new organisation was put in place in order to work more as an integrated Group and to propose to Customers always better convergence solutions. This new organisation is built in a matrix form meaning that some responsables will have an organisational (fixed-mobile) responsibility and a hierarchical responsibility in the originating company.

The organisational structure is laying upon 4 pillars:

- Consumer Business Unit (CBU) has the responsibility over the residential customers
- Enterprise Business Unit (EBU) has the responsibility over the professional customers
- Service Delivery Engine (SDE) centralises network and IT services
- Staff and support (S&S) groups all horizontal functions sustaining the Group activities

Although this is a complete new structure there was no impact on the costs for the Belgacom SA model as the subsidiaries kept their legal entity structure.

On October 1, 2008 there has been an integration of the Staff and Support personnel of Mobile, Telindus and Skynet meaning that involved personnel received a Belgacom contract and as such salary costs were in the Belgacom books of accounts. However re-invoicing was made for activities performed to these subsidiaries.

For information, find below the organisation as it was put in place on January 1, 2008:

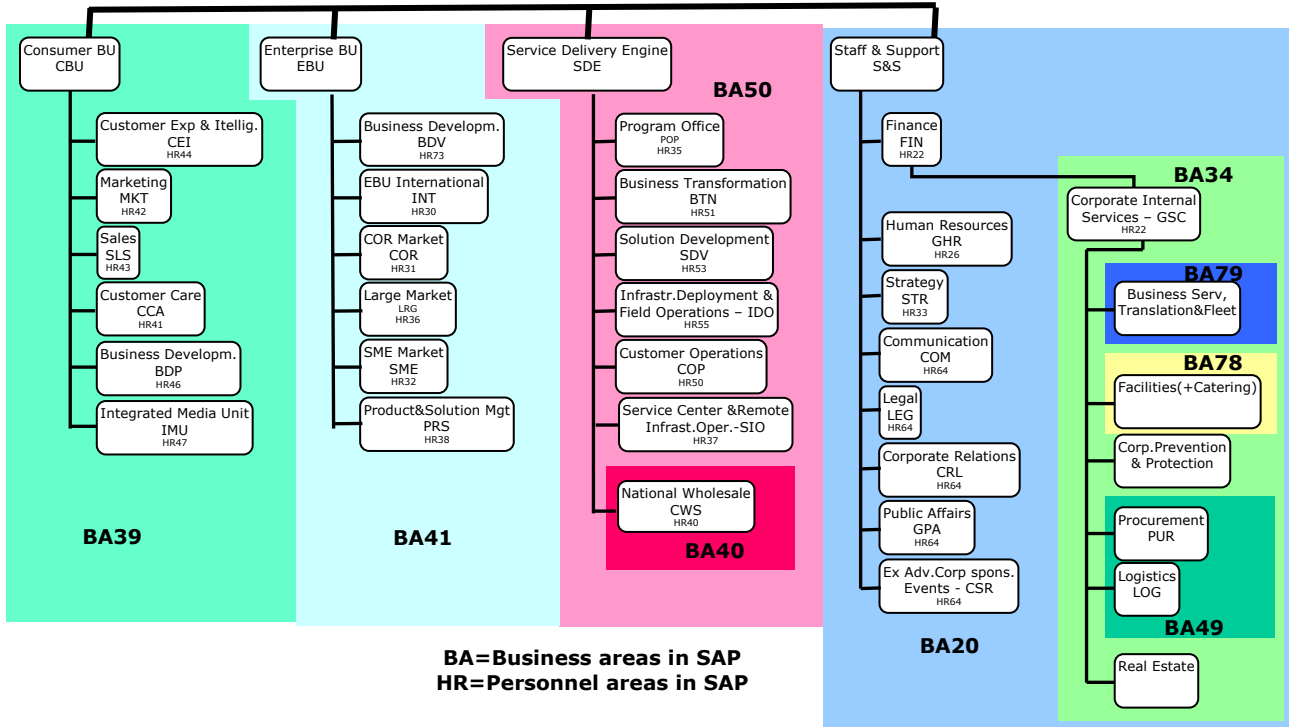

- This organisation re-introduces a clear split between the residential and professional customers by creating the division Consumer and Enterprise Business Units.
- The Service Delivery Engine brings together Network and IT services (formerly named ITN), Customer Operations (COP), Program Office (POP) and Carrier Wholesale (CWS). The content of these blocks remains the same meaning that network and IT services are treated within the Network / IT model whereas COP is treated within ABC with the exception of costs for network cables that are Network / IT related.
- Within Staff & Support the content (FIN, GHR, STR, LEG, COM...) remains the same but a new department was created called Corporate Sponsoring and Events (CSR) grouping all sponsoring activities. Corporate Internal Services grouping internal services like Fleet, Facilities, Prevention&Protection, Procurement... falls under the responsibility of FIN, the Financial department.

Some other specifications:

For the SDE division, when limited to the Belgacom SA component, the different departments already existed as such in the previous organisation (with other names) and have the same level of responsibility, the same span of control as previously. The correspondence between 2008 and 2007 can be summarized as follows:

2008	2007
Business Transformation (SDE/BTN)	-Architecture and Solution Integration (ITN/ASI)
Service Development (SDE/SDV)	-Network & IT solutions (ITN/NIS)
Infrastructure Deployment & Operations (SDE/IDO)	-Infrastructure Planning and Field Operations (ITN/PFO)
Service Center & Infrastructure Operations (SDE/SIO)	-Infrastructure & Remote Operations (ITN/IRO)
Customer Operations (SDE/COP)	- Customer Operations (COP)
Carrier Wholesale Services (SDE/CWS)	- National Wholesale Services (NWS)

As a consequence, the departments BTN, SDV, IDO, SIO are new denominations of the previous departments gathered under ITN. This is the reason why some cost pool objects (team groups) defined in merged Network&IT submodel keep in their denomination references to organisation units of 2007.

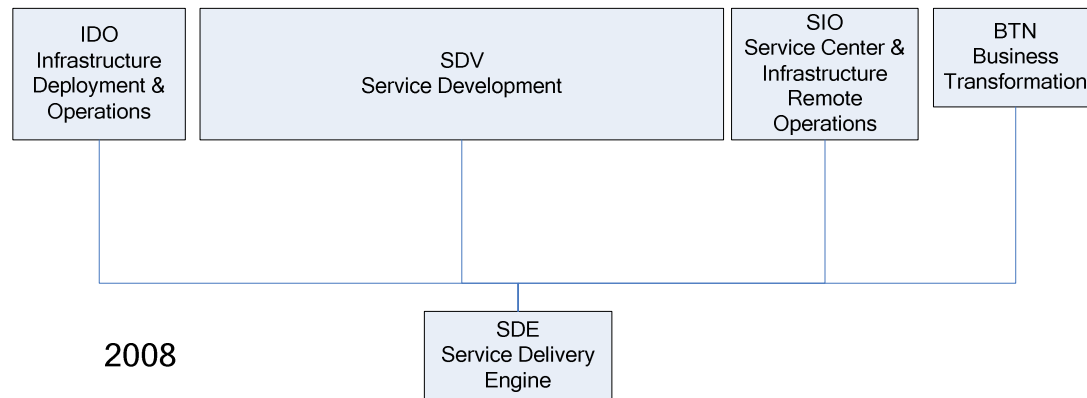
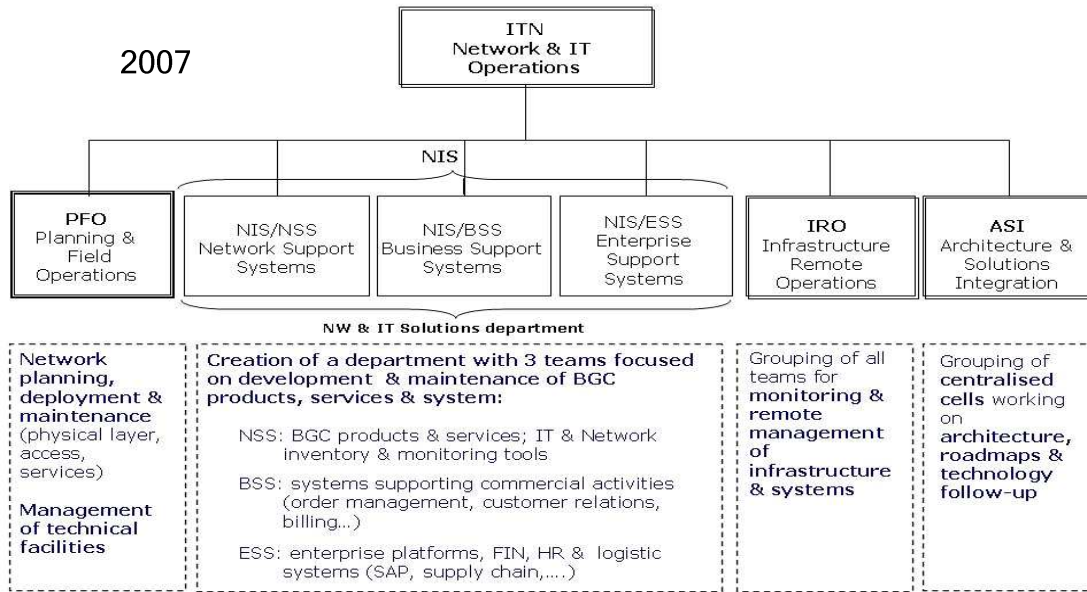

Le département Customer Operations (COP) assure la responsabilité end-to-end pour:

- toutes les activités liées à la gestion des demandes pour produits complexes (gestion des commandes, contact client,...);
- toutes les activités de « repair » de Belgacom (activités à distance & terrain liées client);
- toutes les activités d’installation de Belgacom (activités à distance & terrain liées client);
- la construction, l’entretien et le « repair » du réseau de câbles (cuivre);
- les interventions sur PC et serveurs.

La division Carrier Wholesale (CWS), dont l'organigramme est repris ci-dessous, gère la partie « Wholesale » du Business en relation avec d'autres opérateurs et fournisseurs de service sur le marché belge.

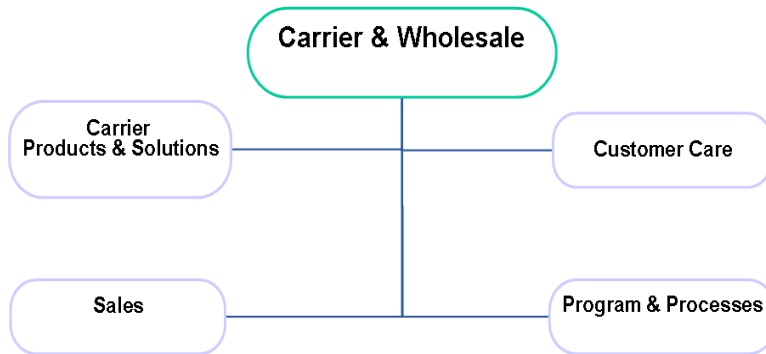

6 THE ABC COST MODEL

6.1 Introduction

The ABC model has been developed by the REG department and has as objective to allocate all costs previously determined and that are not part of the Network / IT model. The products that at the end will bear these costs have also been defined by REG.

The ABC model can be divided in 6 steps (see Figure 1):

- The first step consists in the process of regrouping all costs in, on the one side “cost pools” and on the other side “cost center groups” as was explained under point 3 of this document.
- The second step consists in allocating certain costs directly to the products.
- The third step consists in allocating the remaining costs to the activities.
- The fourth step consists in allocating the support costs to either the primary activities, the management activities, the Network / IT model or directly to the products.
- The fifth step consists in allocating the primary and management activities to the products.
- The sixth step consists in the allocation of the IT costs to the products.

6.2 Detailed description of the allocation steps

For the first step we refer to point 3.

6.2.1 Step 2: Allocating costs directly to the products

The second step consists of allocating costs directly to the products to which they are related.

6.2.1.1 Material out of stock

The MOS is divided into two main categories: CPE and network material.

- For the CPE, there exists in general a 1-to-1 relationship between the costs and the products to which they are related.
- For the network material, the costs are allocated to the products following their descriptions and GL account.

6.2.1.2 Services and other goods

The services and other goods can be classified into 4 major categories: interconnection costs, commissions, infrastructure and other charges:

- Interconnection:

Two cases are possible for allocating these costs to the respective products:

- The nature of the interconnection fee allows allocating the total cost pool directly to the related product. In this case no allocation key is used.
- Cost pools representing 93% of total interconnection costs are allocated on different products pro rata the interconnect invoices paid by Belgacom to the different OLO's.

- Commissions paid to third parties:

- The nature of the commission allows allocating the total cost pool directly to the related product. In this case no allocation key is used.
- Some cost pools group commissions for different products. The allocation is made pro rata the commissions paid to the indirect sales channels on the different products sold by them.

- Infrastructure:

Here we distinguish on one side the costs for the international infrastructure (56,7%) and on the other side the costs for the national infrastructure (43,3%). For the international infrastructure these costs are allocated to the products (data BES, BWS, internat. satellite) either directly or following a detailed analysis done by the EBU division. For national infrastructure these costs are mainly allocated to the products (iDTV, PSTN, ISDN, ADSL...) on the basis of the outsourced invoices within the COP department and linked to customers' installations.

6.2.1.3 Remuneration, social security costs and pensions.

Within some departments and cost center groups, the remuneration costs could be allocated directly to the products. This is especially the case for activities within Staff and Support on behalf of the affiliates. Due to the integration of Staff and Support personnel of Mobile, Telindus and Skynet as from October, 1 onwards this directly allocation is becoming more important. These costs are booked on product "Subsidiaries&Externals".

6.2.1.4 Depreciation, write-offs, provisions for liabilities and WACC

These costs are allocated to products on the basis of the underlying assets. Mainly they are allocated on the product line Customer Premises Equipment (CPE) and iDTV.

6.2.2 Step 3: Allocating indirect costs to activities

In the model 3 different types of activities appear:

- The **primary** activities give directly an added value to the products. They cover:
 - Strategy, product and market management
 - Fulfilment: from sales, order handling to delivery
 - Service assurance: from services after sales to repairing
 - Billing and collection
 - Network Build & Maintenance
- The **management** activities are essential for a good functioning of the company. They cover:
 - Human resource management
 - Financial management
 - Administration and general support
 - Management improvement and change
- The **support** activities covering:
 - Supply chain and facilities services
 - IT services. As from 2007 these costs are treated differently. See under point 6.2.3, 6.2.3.1 and 6.2.5.

These 11 processes are divided into 44 sub-processes which on their side contain 207 activities. It is on these activities that the indirect costs will be allocated. Cost center groups, cost pools or the combination of both determine in which activities they are involved.

In general we can say that there are 5 methodologies to allocate the indirect costs:

- *Objective measurements going directly to the activity*
 - On the basis of the work hours performed by the technicians (level 2A, 3 and 4) in the “Voice” and “Data” sections within COP/CFO.
 - The cost pool “salaries” and the personnel costs linked to this category of workers are allocated to the activities thanks to this methodology.
- *Objective measurements of the FTE input*
 - Based on the number of FTEs (full time equivalents) working on a certain activity. The ABC model takes the annual average number of FTEs.
 - The cost pool “salaries” and the personnel costs linked to this category of employees are allocated to the activities thanks to this methodology.
- *Assignment based on a cost pool*

In certain cases, there is a direct link between a cost pool and an activity: e.g. cost pool 6400 “tax fleet utility” goes directly to the activity 6.4.1 “Manage, maintain and repair utility vehicles”.

- *Assignment on the combination cost center group and cost pool*
 - The combination cost pool 6010 “Network materials” and CCG 78400 “GSC-IFM-BTS-Building & Technical Services” goes to the activity 6.2.2 “Manage, maintain & repair buildings”.
 - The combination cost pool 61070 “waste” and CCG 49480 “CSM-LOG-Waste mgmt” goes to activity 6.1.7 “Manage waste and scrap”.

- *Assignment on the basis of a specific analysis allowing to establish a causal relationship*

E.g. energy costs are distributed on the basis of a logical analysis between:

- 6.2.2 “Manage, maintain and repair buildings”
- 6.3.1 “ Manage the power chain for telecom infrastructure”

6.2.3 Step 4: Allocation of the support costs

This step has as objective to allocate the support costs to:

- Primary and management activities
- Directly to the products
- The Network / IT model

In these costs we find:

- The majority of the costs re. GSC (Corporate Internal Services) department
- The majority of the costs re. CSM department
- Other support costs (activities provided by other divisions like FIN, CBU, EBU)

The costs of the support activities are allocated following a cascade principle. There is no mutual assignment. Once the cost of a support activity has been allocated, this activity can no more receive any other cost.

6.2.3.1 Allocation of the IT activities (process 7)

Like in 2007 these costs have been allocated directly to all ABC products as a mark-up percentage using total costs per ABC product as key. This allocation is in line with the BIPT methodology (BRUO, BROTSOLL) and is made without prejudice and any adverse recognition.

6.2.3.2 Allocation of the logistics activities (process 6)

The logistics activities of process 6 are principally realised by the GSC and CSM departments. The logistics activities carried out by other divisions are allocated on the products/activities of the concerned division.

6.2.3.2.1 ALLOCATION OF BUILDING COSTS

These activities are mainly delivered by the GSC department.

The database “Speedikon” manages the space occupied by each division and this for each type of building. The square meters are classified by:

- *Room categories*: housing, office, parking, shop, storage, technical building, technical telecom, unusable, workshop.
- *Type of room category*: e.g. for the storage category, we distinguish the following 3 types: archives, reserves and warehouse.

Based on this information, each square meter is allocated to one of the ABC categories following the causality principle. The ABC categories will be the basis for allocating the cost of buildings to intermediate (other activities) and final objects (products) of the cost model.

6.2.3.2.2 ALLOCATION OF FLEET COSTS.

The FMS database gives the number of vehicles of Belgacom SA in 3 categories: management, sales and utility cars and this for each division. Information on fuel consumption is also available. The general key is the number of vehicles per category per activity within a division.

6.2.3.2.3 ALLOCATION OF OTHER FACILITIES COSTS.

The activities assigned in this step concern energy, moves, internal mail distribution, etc.....

Moves

The activity “moves” is allocated following the number of office moves within a division.

Internal mail distribution

This activity is assigned to activities using this kind of services (mainly the activities defined as office activities). The number of FTE carrying out these activities is the key.

Catering

Catering is allocated over the activities using the catering service (mainly the activities defined as office activities) using the number of FTE carrying out these activities as key.

Print and copy shops

This activity is assigned to the activities using the different print and copy shop services (outgoing invoices excluded). The key can either be the number of transactions (mailings) registered by the print shop of Libramont, the value of the purchase order or the number of FTEs using these activities (copy shop costs).

Energy telecom

The energy costs feeding the telecom equipments are allocated to the concerned divisions depending on the consumption measured in Mwh or amperes

6.2.3.2.4 ALLOCATION OF THE SUPPLY CHAIN ACTIVITIES COSTS.

These activities are allocated in 5 steps. Sometimes the supply chain costs can also be assigned directly to a product as there may be a causal relationship.

The first allocation refers to: waste grid

The waste costs are divided over the different concerned divisions – SDE/COP (for telecom waste), CSM (waste linked to the supply chain) and GSC (office waste).

The cost for SDE/IT&N goes to the Network / IT model. The CSM costs are mainly allocated to the CPEs and iDTV based on the number of picking lines. The other costs of GSC are assigned to office activities depending on the number of square meters used.

The second allocation refers to: purchasing and APC grid

For the purchase activity, the initial key is the purchase/contract order values per division and per S&OG type; the secondary key is based on the combined cost of this S&OG with the activity and/or product associated within the division.

For the treatment and follow-up of invoices, the primary key is the number of invoices weighted in lines per division and per SOG type; the secondary key is the combination with the activities and/or products of the division.

The third allocation refers to: warehousing grid

The activity linked to the warehouse management is allocated in function of the number of “picking” lines (as well as for the consumption materials and the goods transferred to other stores) per division and per good. The secondary key combines this with the activities and/or products of the division.

The fourth allocation refers to: transport grid

The activity linked to the internal distribution is allocated in function of the transported volumes and delivery destination (point of sales, secured area...).

The fifth allocation refers to: cables and reverse logistics grid

The activity linked to cables is allocated directly to the Network / IT model.

The activity linked to the treatment of re-entries is allocated in function of the number of picking lines per good.

6.2.4 Step 5: Allocation of the primary and management activities to the products

In the fifth and last step primary and management activities are allocated to products. At this stage in the model all support activities have already been distributed and are as such included in the primary and management activities.

The REG department has defined a key for each activity/division combination. Such a key has been defined for every activity of the ABC dictionary taking into account the division executing this activity.

6.1.1.1 Allocation of the primary activities.

These activities are part of the following processes:

6.2.4.1.1 PROCESS 1: STRATEGY, PRODUCT AND MARKET MANAGEMENT.

Activity	Division	Driver
1.1.1. Plan, develop and manage business	20_CRL	Generic. Calculated EBU&CBU-cost per product for the whole of process 1 (excl. 1.4.8.), to come to percentage of cost per product to use as key for this activity
1.1.1. Plan, develop and manage business	20_FIN	Generic. Calculated overall BGC-cost per product for the whole of process 1 (excl. 1.4.8.), to come to percentage of cost per product to use as key for this activity
1.1.1. Plan, develop and manage business	20_GHQ	Generic. Calculated overall BGC-cost per product for the whole of process 1 (excl. 1.4.8.), to come to percentage of cost per product to use as key for this activity
1.1.1. Plan, develop and manage business	20_STR	Generic. Calculated overall BGC-cost per product for the whole of process 1 (excl. 1.4.8.), to come to percentage of cost per product to use as key for this activity
1.1.1. Plan, develop and manage business	39_CBU	Generic. Calculated CBU-cost per product for the whole of process 1 (excl. 1.4.8.), to come to percentage of cost per product to use as key for this activity
1.1.1. Plan, develop and manage business	40_CWS	FTE per product
1.1.1. Plan, develop and manage business	41_EBU	Generic. Calculated EBU-cost per product for the whole of process 1 (excl. 1.4.8.), to come to percentage of cost per product to use as key for this activity
1.1.2. Manage scarce resources	20_FIN	Generic. Calculated overall BGC-cost per product for the whole of process 1 (excl. 1.4.8.), to come to percentage of cost per product to use as key for this activity
1.2.1. Propose, develop and launch new products / services or enhancements to existing products / services	39_CBU	FTE per product
1.2.1. Propose, develop and launch new products / services or enhancements to existing products / services	40_CWS	FTE per product
1.2.1. Propose, develop and launch new products / services or enhancements to existing products / services	41_EBU	FTE per product

1.2.2. Manage existing products / services	39_CBU	FTE per product
1.2.2. Manage existing products / services	40_CWS	FTE per product
1.2.2. Manage existing products / services	41_EBU	FTE per product
1.2.3. Withdraw products / services	41_EBU	FTE per product
1.3.1. Propose, develop and launch pricing actions	39_CBU	FTE per product
1.3.1. Propose, develop and launch pricing actions	40_CWS	FTE per product
1.3.1. Propose, develop and launch pricing actions	41_EBU	FTE per product
1.4.1. Manage product solutions and growth marketing programs	39_CBU	FTE per product
1.4.1. Manage product solutions and growth marketing programs	41_EBU	FTE per product
1.4.2. Manage customer win-back and retention / loyalty marketing programs	39_CBU	Combined key: Expert opinion + R&V for the sales part FTE per product for the MKT part
1.4.2. Manage customer win-back and retention / loyalty marketing programs	41_EBU	Combined key: Expert opinion + R&V for the sales part FTE per product for the MKT part
1.4.3. Manage marketing activities of direct sales channels	39_CBU	Combined key: Actuals sales volumes TBS * sales time for the sales part FTE per product for the MKT part
1.4.3. Manage marketing activities of direct sales channels	41_EBU	Combined key: BCI revenues for the sales part FTE per product for the MKT part
1.4.4. Manage marketing activities of indirect sales channels	39_CBU	Combined key: Sold volumes IND * sales time for the sales part FTE per product for the MKT part
1.4.4. Manage marketing activities of indirect sales channels	41_EBU	Combined key: BCI&TNA revenues for the sales part FTE per product for the MKT part
1.4.5. Manage the e-channel	39_CBU	Combined key: E-orders volumes for the sales part FTE per product for the MKT part
1.4.5. Manage the e-channel	40_CWS	E-orders volumes
1.4.6. Business intelligence and customer satisfaction	20_FIN	Direct
1.4.6. Business intelligence and customer satisfaction	20_STR	Generic. Calculated BGC-cost per product for the activities 1.2.1. & 1.2.2., to come to percentage of cost per product to use as key for this activity
1.4.6. Business intelligence and customer satisfaction	34_MST	Direct

1.4.6. Business intelligence and customer satisfaction	39_CBU	FTE per product
1.4.6. Business intelligence and customer satisfaction	41_EBU	Generic. Calculated 41_EBU cost per product for the activities 1.2.1. & 1.2.2., to come to percentage of cost per product to use as key for this activity
1.4.6. Business intelligence and customer satisfaction	50_SDE	Direct
1.4.7. Communication strategy, brand & sponsoring, press & external communication, off-media buying	20_COM	BGC retail product portfolio turnover (terminating rates & BVAS out / DAS OLO revenues taken out)
1.4.7. Communication strategy, brand & sponsoring, press & external communication, off-media buying	20_FIN	BGC retail product portfolio turnover (terminating rates & BVAS out / DAS OLO revenues taken out)
1.4.7. Communication strategy, brand & sponsoring, press & external communication, off-media buying	20_GHQ	BGC retail product portfolio turnover (terminating rates & BVAS out / DAS OLO revenues taken out)
1.4.7. Communication strategy, brand & sponsoring, press & external communication, off-media buying	20_GHR	BGC retail product portfolio turnover (terminating rates & BVAS out / DAS OLO revenues taken out)
1.4.7. Communication strategy, brand & sponsoring, press & external communication, off-media buying	20_GPA	BGC retail product portfolio turnover (terminating rates & BVAS out / DAS OLO revenues taken out)
1.4.7. Communication strategy, brand & sponsoring, press & external communication, off-media buying	39_CBU	FTE per product
1.4.7. Communication strategy, brand & sponsoring, press & external communication, off-media buying	40_CWS	REV CWS product
1.4.7. Communication strategy, brand & sponsoring, press & external communication, off-media buying	41_EBU	FTE per product
1.4.8. Define, develop and launch product / service related advertising	39_CBU	Advertising costs per product
1.4.8. Define, develop and launch product / service related advertising	41_EBU	Advertising costs per product

The main keys for allocating the costs of the activities of process 1 are as follows:

- Allocation depending on the number of FTEs working on each of the products (e.g. EBU and CBU divisions, except for advertising activity based on advertising costs per product).
- Allocation on the basis of revenues/volumes per product.
- Allocation depending on the costs already charged to the products (generic cost allocation). This key is mainly used when a certain activity is carried out in a division within the Corporate Units.
- Some costs can also be allocated directly to one single product.

- Combined key allocation: Due to the re-organisation of the SCS and MKT divisions into EBU and CBU, some activities have a Sales component and a Marketing component which, in the 2007 model, were allocated based on different drivers. For these cases, and in order to maintain the consistency with last years model, the allocation is done in two stages:
 1. Each of the two components is independently allocated to the products on the same basis as in the 2007 model. This is to say:
 - a. The Marketing component is allocated based on FTE per product
 - b. The Sales component allocation, depending on the activity, can be based on:
 - i. the number of sales, often weighted by the average time necessary to sell the product
 - ii. expert opinion and revenues/volumes per product
 - iii. revenues per product
 2. The two allocation components are merged, weighted by the number of contributing FTE per component.

6.2.4.1.2 PROCESS 2: FULFILMENT: ACTIVITIES GOING FROM SALES, ORDER HANDLING TO INSTALLATION.

Activity	Division	Driver
2.1.1. Provide Directory Assistance services	39_CBU	Direct
2.1.2. Provide listing services	39_CBU	Direct
2.1.3. Provide other operator assisted services	39_CBU	Direct
2.2.1. Fulfil marketing numbers requests & sell starfax service	39_CBU	Provisioning orders MKT numbers (new/modify/cancel)
2.2.2. Fulfil call & conference / web & conference requests	39_CBU	Direct
2.3.1. Sell products & services through indirect sales channels	39_CBU	Sold volumes IND * sales time (Mass mkt)
2.3.1. Sell products & services through indirect sales channels	41_EBU	Revenues (Business mkt)
2.3.2. Provide sales & info services in Points Of Sales	39_CBU	Sold volumes POS * sales time
2.3.3. Develop & sell proposals for standard products or integrated solutions (including client visits)	39_CBU	Direct
2.3.3. Develop & sell proposals for standard products or integrated solutions (including client visits)	40_CWS	FTE per product
2.3.3. Develop & sell proposals for standard products or integrated solutions (including client visits)	41_EBU	BCI revenues (ex-SAL) & FTE per product (ex-SDI)
2.3.4. Provide sales & info services through telesales or contact center (voice, fax, letter, e-mail)	20_CRL	Sold volumes CCA * sales time (Mass mkt) & revenues (Business mkt)
2.3.4. Provide sales & info services through telesales or contact center (voice, fax, letter, e-mail)	39_CBU	Sold volumes CCA * sales time (Mass mkt) & revenues (Business mkt)
2.3.5. Negotiate and establish BRIO/BRUO/BROBA agreements with operators / service providers	40_CWS	FTE per product

2.3.6. Close presales, sales and after sales interactions and transactions about products & services through the website channel	39_CBU	Sold volumes ECA & STP rate
2.4.1. Ensure order fulfilment through account administration	39_CBU	Generic. Calculated CBU-cost per product for the sub-process 2.4. (CBU order handling activities costs), to come to percentage of cost per product to use as key for this activity
2.4.1. Ensure order fulfilment through account administration	40_CWS	Generic. Calculated CWS-cost per product for the sub-process 2.4. excluding activities not performed by CSA (i.e., 2.4.6., 2.4.7., 2.4.8., 2.4.9., 2.4.10.), to come to percentage of cost per product to use as key for this activity
2.4.1. Ensure order fulfilment through account administration	41_EBU	Generic. Calculated EBU-cost per product for the sub-process 2.4. (EBU order handling activities costs), to come to percentage of cost per product to use as key for this activity
2.4.10. Handle customer orders for NP OP and CPS	39_CBU	FTE per product
2.4.10. Handle customer orders for NP OP and CPS	40_CWS	FTE per product
2.4.11. Handle customer orders for calling cards	39_CBU	Direct
2.4.12. Handle customer orders for payphones	39_CBU	Expert opinion
2.4.13. Handle customer orders for BILAN Teleworking and Internet for Employees Solutions	39_CBU	Direct
2.4.15. Handle customer orders for centrex, CUG, VPN and BUC	39_CBU	Order handling BCI cases
2.4.17. Handle customer orders for national leased lines	40_CWS	Provisioning volumes
2.4.17. Handle customer orders for national leased lines	50_SDE	Provisioning volumes
2.4.18. Handle customer orders for international leased lines (IPLC, BES ELL, Satellites)	50_SDE	Provisioning volumes
2.4.19. Handle customer orders for DCS/X.25 solutions	39_CBU	Direct
2.4.2. Ensure fulfilment of customer orders placed via indirect channels	39_CBU	IND volumes, per segment
2.4.20. Handle customer orders for Explore solutions and equivalents	39_CBU	Customer orders
2.4.20. Handle customer orders for Explore solutions and equivalents	41_EBU	Customer orders
2.4.20. Handle customer orders for Explore solutions and equivalents	50_SDE	Customer orders
2.4.21. Handle customer orders for web services and applications	39_CBU	Direct

2.4.22. Handle customer orders for Internet connectivity & services	39_CBU	Expert opinion
2.4.23. Handle customer orders for PRA connections	39_CBU	Direct
2.4.3. Handle customer orders for usage / deduction plans, bundles, MVAS, promotions, itemized billing, fulfilment and SLA changes	39_CBU	Nbr of orders
2.4.4. Handle customer orders for PSTN, ISDN BA, Internet GO/PLUS, Internet Light, Internet Time Based Billing, Internet Budget, VDSL Boost, iDTV internet, iDTV without internet, I-Talk, CPEs (PABX, ADSL modems, etc.) and Internet without voice	39_CBU	BCI order handling cases * OH time
2.4.4. Handle customer orders for PSTN, ISDN BA, Internet GO/PLUS, Internet Light, Internet Time Based Billing, Internet Budget, VDSL Boost, iDTV internet, iDTV without internet, I-Talk, CPEs (PABX, ADSL modems, etc.) and Internet without voice	40_CWS	Provisioning volumes
2.4.5. Handle customer orders for ADSL Pro/Office, SDSL and VDSL Office FI solutions	39_CBU	BCI order handling cases * OH time
2.4.6. Handle customer orders for housing, collocation, co-mingling, tie cables and blocks	40_CWS	FTE per product
2.4.8. Handle customer orders for BROBA II - ATM transport	40_CWS	Direct
2.4.9. Handle customer orders for BRUO & BROBA products - end user level	40_CWS	FTE per product
2.5.1. Execute remote provisioning of PILA products (IAC)	50_SDE	Minutes per product
2.5.2. Execute remote provisioning of PRA and leased lines	50_SDE	Provisioning volumes
2.5.3. Execute remote provisioning of interconnect / wholesale links/BBA	50_SDE	Provisioning volumes
2.5.4. Execute remote provisioning of Explore solutions and equivalents	50_SDE	Provisioning volumes
2.5.5. Execute remote provisioning of ADSL Pro/Office, SDSL and VDSL Office FI solutions	50_SDE	Provisioning volumes
2.5.6. Execute remote provisioning of BROBA end-user lines & VP	50_SDE	Provisioning volumes
2.5.7. Execute remote provisioning of DCS/X.25 solutions	50_SDE	Direct
2.6.1. Coordinate provisioning work orders for PRA and leased lines	50_SDE	Provisioning volumes
2.6.2. Coordinate provisioning work orders for Explore solutions and equivalents	50_SDE	Direct
2.6.3. Coordinate provisioning work orders for ADSL Pro/Office, SDSL and VDSL Office FI solutions	50_SDE	Provisioning volumes

2.6.4. Dispatch, monitor and close provisioning work orders - IDC voice/data cells	50_SDE	CLARA work orders
2.6.6. Dispatch, monitor and close Cu splicing work orders related to the introduction cable - IDC CAB cells	50_SDE	Dispatched splicing work orders - introduction cable (IDC CAB cells)
2.7.1. Execute pre- or post-installation work	50_SDE	Generic. Calculated COP cost per product for the sub-process 2.7. (COP field installation activities costs), to come to percentage of cost per product to use as key for this activity
2.7.1. Execute pre- or post-installation work	79_BSF	Generic. Calculated COP cost per product for the sub-process 2.7. (COP field installation activities costs), to come to percentage of cost per product to use as key for this activity
2.7.10. Install BRUO & BROBA products - end user level	50_SDE	Provisioning volumes
2.7.10. Install BRUO & BROBA products - end user level	79_BSF	Provisioning volumes
2.7.11. Install low rate leased line	50_SDE	Number of installed / modified leased lines
2.7.11. Install low rate leased line	79_BSF	Number of installed / modified leased lines
2.7.12. Install leased line high rate	50_SDE	Number of installed / modified leased lines
2.7.12. Install leased line high rate	79_BSF	Number of installed / modified leased lines
2.7.15. Install SDSL line	50_SDE	Provisioning volumes
2.7.15. Install SDSL line	79_BSF	Provisioning volumes
2.7.16. Install VDSL Office line	50_SDE	Direct
2.7.16. Install VDSL Office line	79_BSF	Direct
2.7.2. Install PSTN line	50_SDE	CLARA work orders
2.7.2. Install PSTN line	79_BSF	CLARA work orders
2.7.22. Install voice / data CPE equipment (managed services)	50_SDE	Direct
2.7.22. Install voice / data CPE equipment (managed services)	79_BSF	Direct
2.7.26. Execute internal / structured cabling work	50_SDE	Direct
2.7.3. Install ISDN BA line	50_SDE	CLARA work orders
2.7.3. Install ISDN BA line	79_BSF	CLARA work orders
2.7.4. Install PABX	50_SDE	Direct
2.7.4. Install PABX	79_BSF	Direct
2.7.6. Install payphone	50_SDE	Nb interventions
2.7.6. Install payphone	79_BSF	Nb interventions
2.7.7. Install Internet GO/PLUS line	50_SDE	Provisioning volumes
2.7.7. Install Internet GO/PLUS line	79_BSF	Provisioning volumes
2.7.8. Install ADSL Pro/Office line	50_SDE	Provisioning volumes
2.7.8. Install ADSL Pro/Office line	79_BSF	Provisioning volumes

2.7.9. Install iDTV service	20_CRL	Direct
2.7.9. Install iDTV service	50_SDE	Direct
2.7.9. Install iDTV service	79_BSF	Direct
2.8.1. Manage and support sales activities (inc. training & coaching of sales channels)	20_CRL	Generic. Calculated CRL-cost per product for the sub-process 2.3. (RL pre-sales & sales costs), to come to percentage of cost per product to use as key for this activity
2.8.1. Manage and support sales activities (inc. training & coaching of sales channels)	39_CBU	Generic. Calculated CBU-cost per product for the sub-process 2.3. (CBU pre-sales & sales costs), to come to percentage of cost per product to use as key for this activity
2.8.1. Manage and support sales activities (inc. training & coaching of sales channels)	41_EBU	Generic. Calculated EBU-cost per product for the sub-process 2.3. (EBU pre-sales & sales costs), to come to percentage of cost per product to use as key for this activity
2.8.2. Manage, document and optimize provisioning activities	39_CBU	Generic. Calculated CBU-cost per product for the process 2 excluding sub-processes 2.1. & 2.3., to come to percentage of cost per product to use as key for this activity
2.8.2. Manage, document and optimize provisioning activities	40_CWS	Generic. Calculated CWS-cost per product for the process 2 excluding sub-processes 2.1. & 2.3., to come to percentage of cost per product to use as key for this activity
2.8.2. Manage, document and optimize provisioning activities	41_EBU	Generic. Calculated EBU-cost per product for the process 2 excluding sub-processes 2.1. & 2.3., to come to percentage of cost per product to use as key for this activity
2.8.2. Manage, document and optimize provisioning activities	50_SDE	Generic. Calculated SDE cost per product for the process 2 excluding sub-processes 2.1. & 2.3., to come to percentage of cost per product to use as key for this activity
2.8.3. Training and on-the-job coaching - provisioning	39_CBU	Generic. Calculated CBU cost per product for the process 2 excluding sub-processes 2.1. & 2.3., to come to percentage of cost per product to use as key for this activity
2.8.3. Training and on-the-job coaching - provisioning	50_SDE	Generic. Calculated SDE cost per product for the process 2 excluding sub-processes 2.1. & 2.3., to come to percentage of cost per product to use as key for this activity
2.8.4. Manage projects related to the implementation of telecom & IT solutions	40_CWS	FTE per product

2.8.4. Manage projects related to the implementation of telecom & IT solutions	41_EBU	FTE per product
2.8.4. Manage projects related to the implementation of telecom & IT solutions	50_SDE	Provisioning volumes + expert opinion

For a better understanding we distinguish 7 different types of activities in this process:

- Activities linked to DIS (Directory Information Services)
- Activities linked to some specific products
- Activities linked to sales
- Activities linked to remote provisioning
- Activities linked to order handling
- Activities linked to work orders provisioning
- Activities linked to installations

Activities linked to DIS

There is a direct link between these activities and the related ABC products.

Activities linked to some specific products

For the costs of these activities the allocation can either be done:

- Because the analytical bookkeeping can find a direct link to the products
- Because the costs of these activities can be allocated based on the customers orders volumes

Activities linked to sales

- In some cases the analytical bookkeeping can find a direct link to the products.
- The costs for some activities can be allocated based on the number of sales, often weighted with the average time necessary to sell the product.
- Some activities are in a first instance allocated depending on the number of FTEs and in a second phase taking into account turnover or volumes.

Activities linked to remote provisioning

- One key is based on minutes per product split on basis of provisioning volumes to reach final percentage.
- In other cases the analytical bookkeeping can find a direct link to the products or to a category to which a product may belong. If it is a product category, a second key will be used. This can either be the number of work orders, the number of connections...

Activities linked to order handling and work orders provisioning

- In some cases the analytical bookkeeping can find a direct link to the products or to a category to which a product may belong.
- Costs are allocated based on volumes (customer's orders, provisioning...).
- The costs for voice & data order handling within COP are allocated to the products based on CLARA (where the number of work orders are registered, associated to a standard time per product).
- Some activities are in a first instance allocated depending on the number of FTEs and in a second phase taking into account turnover or volumes.

Activities linked to installations

- In some cases the analytical bookkeeping can find a direct link to the products or to a category to which a product may belong. If it is a product category, a second key will be used. This can either be the number of work orders, the number of connections...
- Some installation costs are allocated based on CLARA (where the number of work orders are registered, associated to a standard time per product)
- Some activities are in a first instance allocated depending on the number of FTEs and in a second phase taking into account turnover or volumes.

Allocation depending on the costs already charged to the products is also often taken especially for activities in the support area (generic cost allocation).

6.2.4.1.3 PROCESS 3: SERVICE ASSURANCE: FAULT HANDLING AND REPAIRING

Activity	Division	Driver
3.1.1. Receive and handle complaints or fault reports related to marketing numbers / starfax	39_CBU	After-sales tickets MKT nbrs
3.1.2. Receive and handle complaints or fault reports related to call & conference / web & conference	39_CBU	Direct
3.2.1. Receive and handle customer inquiries or complaints not related to billing / marketing numbers / teleconferencing	39_CBU	After-sales BCI cases CBU/EBU, excluding BVAS
3.2.1. Receive and handle customer inquiries or complaints not related to billing / marketing numbers / teleconferencing	41_EBU	After-sales BCI cases EBU, excluding BVAS
3.2.1. Receive and handle customer inquiries or complaints not related to billing / marketing numbers / teleconferencing	50_SDE	After-sales BCI cases, excluding BVAS
3.2.3. Provide operational support for specific telecom & IT projects	50_SDE	Direct
3.3.1. Receive and handle fault reports related to Internet GO/PLUS	50_SDE	FTE per product
3.3.4. Receive and handle fault reports related to home, business & voice products	50_SDE	Nbr of calls * AHT
3.3.5. Receive and handle fault reports related to corporate, carrier & data products	40_CWS	Nbr UTS wholesale-related trouble tickets
3.3.5. Receive and handle fault reports related to corporate, carrier & data products	50_SDE	Nbr UTS trouble tickets
3.3.8. Receive and handle fault reports related to the iDTV end-user service	50_SDE	Direct
3.4.3. Execute remote repair of Explore solutions and equivalents and ensure pro-active monitoring	50_SDE	Sites' volumes
3.4.4. Execute remote repair of leased lines	50_SDE	Subscription volumes
3.4.5. Execute remote repair of DCS/X.25	50_SDE	Direct

solutions		
3.4.6. Execute remote repair of ADSL Pro/Office, SDSL & VDSL Office FI solutions	50_SDE	Subscription volumes
3.4.7. Execute remote repair of BRUO and BROBA solutions	50_SDE	Repair time
3.4.8. Execute remote repair of DNS, hosting and mail services and ensure pro-active monitoring	50_SDE	Direct
3.5.1. Dispatch, monitor and close repair work orders - IDC voice/data cells	50_SDE	CLARA work orders
3.5.3. Dispatch, monitor and close Cu splicing work orders related to the repair of cable network - IDC CAB cells	50_SDE	Generic - top 99% CP_Cu-Feeding & CP_Cu-Distribution allocation to products
3.6.1. Execute pre- or post-repair work	50_SDE	Generic. Calculated SDE cost per product for the sub-process 3.6. (field repair), to come to percentage of cost per product to use as key for this activity
3.6.1. Execute pre- or post-repair work	79_BSF	Generic. Calculated BSF cost per product for the sub-process 3.6. (field repair), to come to percentage of cost per product to use as key for this activity
3.6.10. Repair low rate leased line	50_SDE	UTS field trouble tickets
3.6.10. Repair low rate leased line	79_BSF	UTS field trouble tickets
3.6.11. Repair high rate leased line	50_SDE	UTS field trouble tickets
3.6.11. Repair high rate leased line	79_BSF	UTS field trouble tickets
3.6.14. Repair SDSL line	50_SDE	Subscription volumes
3.6.14. Repair SDSL line	79_BSF	Subscription volumes
3.6.15. Repair VDSL Office line	50_SDE	Direct
3.6.15. Repair VDSL Office line	79_BSF	Direct
3.6.2. Repair PSTN line	50_SDE	Subscription volumes
3.6.2. Repair PSTN line	79_BSF	Subscription volumes
3.6.21. Repair voice / data CPE equipment (managed services)	50_SDE	Direct
3.6.21. Repair voice / data CPE equipment (managed services)	79_BSF	Direct
3.6.24. Repair BiLAN/Explore access line	50_SDE	Field interventions
3.6.24. Repair BiLAN/Explore access line	79_BSF	Field interventions
3.6.3. Repair ISDN BA line	50_SDE	Subscription volumes
3.6.3. Repair ISDN BA line	79_BSF	Subscription volumes
3.6.4. Repair PABX	50_SDE	Direct
3.6.4. Repair PABX	79_BSF	Direct
3.6.6. Repair and maintain payphone	50_SDE	Nb interventions
3.6.6. Repair and maintain payphone	79_BSF	Nb interventions
3.6.7. Repair XDSL line or TV or i-Talk	50_SDE	CLARA repair DU & subscr volumes
3.6.7. Repair XDSL line or TV or i-Talk	79_BSF	CLARA repair DU & subscr volumes

3.6.9. Repair BRUO & BROBA products - end user level	50_SDE	Repair time
3.6.9. Repair BRUO & BROBA products - end user level	79_BSF	Repair time
3.7.1. Manage, document and optimize assurance activities	39_CBU	Generic. Calculated CBU cost per product for the process 3, to come to percentage of cost per product to use as key for this activity
3.7.1. Manage, document and optimize assurance activities	50_SDE	Generic. Calculated SDE-cost per product for the process 3, to come to percentage of cost per product to use as key for this activity
3.7.2. Training and on-the-job coaching - assurance	39_CBU	Generic. Calculated CBU cost per product for the process 3, to come to percentage of cost per product to use as key for this activity
3.7.2. Training and on-the-job coaching - assurance	50_SDE	Generic. Calculated SDE-cost per product for the process 3, to come to percentage of cost per product to use as key for this activity

- In some cases the analytical bookkeeping can find a direct link to the products or to a category to which a product may belong. If it is a product category, a second key will be used (e.g. number of subscriptions or repair time).
- The cost for certain activities “service after sales” is allocated to the products based on the number of complaints or the number of trouble tickets registered. A second key is often used normally based on the number of subscriptions.
- Some other activities of process 3 are allocated based on the number of FTEs per product.
- Some repair costs are allocated based on CLARA (where the number of work orders are registered, associated to a standard time per product).
- In some cases a generic cost allocation is used depending on the costs already charged to the products.

6.2.4.1.4 PROCESS 4: BILLING AND COLLECTION

Activity	Division	Driver
4.1.1. Receive and handle billing inquiries & complaints (not related to marketing nbrs / teleconf.) and make necessary corrections	20_CRL	Billing related BCI cases
4.1.1. Receive and handle billing inquiries & complaints (not related to marketing nbrs / teleconf.) and make necessary corrections	39_CBU	Billing related BCI cases
4.1.1. Receive and handle billing inquiries & complaints (not related to marketing nbrs / teleconf.) and make necessary corrections	40_CWS	Avg subscription volumes CWS of products invoiced through COB
4.1.1. Receive and handle billing inquiries & complaints (not related to marketing nbrs / teleconf.) and make necessary corrections	41_EBU	Billing related BCI cases EBU

4.2.1. Manage pricing reference data and non-usage / (re)rating / discounting processes	39_CBU	FTE per product
4.2.1. Manage pricing reference data and non-usage / (re)rating / discounting processes	40_CWS	FTE per product
4.2.1. Manage pricing reference data and non-usage / (re)rating / discounting processes	41_EBU	FTE per product
4.2.1. Manage pricing reference data and non-usage / (re)rating / discounting processes	50_SDE	FTE per product
4.2.2. Manage customer database, discounts (not fulfilment related) and COB billing activation (work items)	40_CWS	Provisioning volumes
4.2.3. Manage printing, fulfilment and distribution of COB invoices	78_IFM	Nbr of COB invoices/div (diff. postage costs) - billing cycle CBU/EBU/CWS
4.2.4. Manage new billing developments	39_CBU	Billing cycle CBU/EBU
4.2.5. Manage and control the billing related operations (billing system & bill production) including processes such as revenue assurance, contingency, rejection handling, production control, etc.	39_CBU	Generic. Calculated cost per product for the whole of sub-processes 4.1., 4.2. & 4.3., to come to percentage of cost per product to use as key for this activity
4.2.6. Manage and control the directory data (DIMS) including processes such as contingency, rejection handling, production control, etc.	39_CBU	CF reporting
4.2.7. Manage and control the Soccabis data including processes such as provisioning, contingency, rejection handling, production control, etc.	39_CBU	FTE per product
4.2.8. Manage and control billing related financial flows	20_FIN	Generic. Calculated BGC cost per product for the whole of sub-processes 4.1., 4.2. & 4.3., to come to percentage of cost per product to use as key for this activity
4.3.1. Prevent, investigate & detect customer fraud	34_SEC	FTE/Scorecard/revenues
4.3.1. Prevent, investigate & detect customer fraud	39_CBU	FTE/Scorecard/revenues
4.3.2. Manage payments	39_CBU	Nbr of invoices/div - billing cycle CBU/EBU
4.3.2. Manage payments	49_CSM	Nbr of invoices/div - billing cycle CBU/EBU
4.3.3. Manage debit collection	20_FIN	Turnover per product of sample BGC unpaid invoices (invoices with due date 2008 and customer status: DCO, CRT, DFR, BAN, DNO, DON, REC)
4.3.3. Manage debit collection	39_CBU	Turnover per product of sample CBU/EBU unpaid invoices (invoices with due date 2008 and customer status: DCO, CRT, DFR, BAN, DNO, DON, REC)

4.3.3. Manage debit collection	40_CWS	Turnover per product of sample CWS unpaid invoices (invoices with due date 2008 and customer status: DCO, CRT, DFR, BAN, DNO, DON, REC)
4.3.3. Manage debit collection (bad debt)	39_CBU	Turnover per product of sample CBU unpaid invoices (invoices with due date 2008 and customer status: DCO, CRT, DFR, BAN, DNO, DON, REC)
4.3.3. Manage debit collection (bad debt)	40_CWS	Turnover doubtful CWS COB invoices
4.3.3. Manage debit collection (bad debt)	41_EBU	Turnover per product of sample EBU unpaid invoices (invoices with due date 2008 and customer status: DCO, CRT, DFR, BAN, DNO, DON, REC)
4.4.1. Manage manual bills / credit notes	20_FIN	Number of CBU/EBU manual invoices/credit notes
4.4.1. Manage manual bills / credit notes	20_GHQ	Number of BGC manual invoices/credit notes
4.4.1. Manage manual bills / credit notes	20_LEG	Number of CBU/EBU manual invoices/credit notes
4.4.1. Manage manual bills / credit notes	34_SEC	Number of BGC manual invoices/credit notes
4.4.1. Manage manual bills / credit notes	39_CBU	Number of CBU manual invoices/credit notes
4.4.1. Manage manual bills / credit notes	40_CWS	Number of CWS manual invoices/credit notes
4.4.1. Manage manual bills / credit notes	41_EBU	Number of EBU manual invoices/credit notes
4.4.1. Manage manual bills / credit notes	49_CSM	Number of CSM manual invoices/credit notes
4.4.1. Manage manual bills / credit notes (bad debt)	20_FIN	Number of CBU/EBU manual invoices/credit notes
4.4.1. Manage manual bills / credit notes (bad debt)	39_CBU	Number of CBU manual invoices/credit notes
4.4.1. Manage manual bills / credit notes (bad debt)	41_EBU	Number of EBU manual invoices/credit notes
4.5.1. Manage national inter-carrier billing & collecting	40_CWS	IBIS national revenues / nbr calls / nbr invoices
4.5.1. Manage national inter-carrier billing & collecting (bad debt)	40_CWS	Turnover doubtful CWS IBIS invoices

- The costs for certain billing activities are allocated based on the number of invoices sent to the customers and/or on the billing cycle per customer segment.

For the printing and distribution activity of the COB invoices, a split is made between the activity distribution by the post office and other non postage expenses (the cost for the stamps is allocated to Belgacom, the remaining is split between Proximus and Belgacom).

- The handling costs for the billing complaints are allocated to product categories based on the number of complaints coded in the systems. A second key (based on the number of subscriptions, the number of calls...) is generally used to allocate these costs to products.
- The cost for the collection activity is allocated to products in function of the turnover linked to unpaid invoices.
- The cost for manual invoices is assigned to the products according to an analytical follow-up in SAP (number of treated invoices).
- Allocation depending on the costs already charged to the products (generic cost allocation).

6.2.4.1.5 PROCESS 5: NETWORK BUILD AND MAINTENANCE

Activity	Division	Driver
5.1.1. Development, engineering and testing of new products & solutions	50_SDE	Direct
5.3.1. Dispatch, monitor and close Cu splicing work orders related to the extension of cable network - IDC CAB cells	50_SDE	Generic - top 99% CP_Cu-Feeding & CP_Cu-Distribution allocation to products
5.4.1. Support and management of access network operations - cable infrastructure	50_SDE	Revenue per product
5.4.3. Support and management of access network operations - safety	50_SDE	Revenue per product
5.4.4. Support and management of access network operations - home installations	50_SDE	Revenue per product
5.4.5. Support and management of access network operations - cable damage & regulation	50_SDE	Revenue per product
5.5.1. Execute remote provisioning of trunk lines	50_SDE	Provisioning volumes

- The support and management activities are allocated to products following revenues of products.
- The dispatching activity for Copper work orders is allocated on the basis of the CP Copper distribution & feeding allocation to products (CP_Cu-Distribution & CP_Cu-Feeding).

6.2.4.2 Allocation of the management activities.

Four processes cover the management activities:

- HR Management
- Financial Management
- Administration & General Support
- Manage improvement and change

For some activities within the management processes a direct allocation is possible, for most of the activities various keys have been worked out.

Management activities are mainly allocated to the products according to the cost of products. This is logic since management activities are overhead-type of activities.

6.2.4.2.1 PROCESS 8: HR MANAGEMENT

The costs linked to the HR management are in general allocated to the products according to the total Belgacom S.A. remuneration costs. In some cases, the keys relate to the remuneration costs of a specific division.

6.2.4.2.2 PROCESS 9: FINANCIAL MANAGEMENT

For the Finance department and the divisions making sales, a blended key based on the turnover for 50% and on the attributed costs for the other 50% is used. For the other divisions a total cost key is used (at divisional level or Belgacom-wide).

6.2.4.2.3 PROCESS 10: ADMINISTRATION & GENERAL SUPPORT

As a general rule the activities included in this process are allocated to the products on the basis of total costs or remuneration costs of the concerned division or of all divisions when the support is Belgacom-wide.

The PBS (Pension Back Service) amount, which only includes the pension charges related to the active personnel and is in line with the cost accepted by the BIPT in the BRIO, is allocated to all Belgacom products on the basis of remunerations. The same key applies to the collective bonus distributed to the personnel.

The REG activity is subject to an analysis in two steps. A first key is computed based on the time spent by the personnel on regulated reference offers (interconnection and access) while the remaining time is allocated to the other products based on total costs. Secondary keys are then computed to get costs assigned to the product level (e.g., ratio 80%-10%-10% for respectively IC traffic, IC links & ATAP, minutes for the IC traffic).

6.2.4.2.4 PROCESS 11: MANAGE IMPROVEMENT AND CHANGE

In this process either a total cost key is used (at divisional level or Belgacom-wide) or a specific or direct key is used according to the nature of the improvement or change project.

6.2.5 Step 6: Allocation of the IT costs

Since the model 2007, the IT costs have been allocated as a mark-up on the costs already received by the ABC products before.

This step is done after allocation of all the other costs to the ABC products.

A total amount of 176 MEUR is treated that way, meaning 6,01 % of the cost base outside IT costs or 5,7 % of the cost base IT costs included.

By the use of this approach, we are fully in line with the BIPT methodology for IT costs in the last regulatory files (e.g. BRUO & BROTSOLL). In these files, the IT costs were computed as a mark-up of 6 % on the costs already determined, a percentage they found in a general study done by Gartner on the average IT costs by industry sector (see § 7.2.2. of the BRUO Rental Fee decision - <http://www.ibpt.be/ShowDoc.aspx?objectID=2383&lang=en>).

This allocation is made without prejudice and any adverse recognition.

7 Network & IT Cost Models

7.1 Introduction

The Network & IT cost model treats the CAPEX costs of the network assets and the IT assets as well as the operational costs related to the network infrastructure and the IT infrastructure/applications. The costs related to the customers are treated by the ABC model.

The network staff and the IT staff of Belgacom are merged in the organisation formerly named Information Technology and Networks (ITN) and in 2008 named Service Delivery Engine (SDE).

The next picture presents the structure of Belgacom SA. The Network and IT staff is included in the business area BA50 (the largest part of SDE) and doesn't include a number of teams - the field operation teams- within the Customer Operations (COP) which are directly in touch with the customers (ABC model). For convenience reasons, in the sequel the Network and IT staff will be denominated as "ITN-COP" to remind that the Network & IT staff also includes teams from the Customer Operations department of SDE (those not in touch with the customers).

New SAP structure 2008 – Belgacom SA

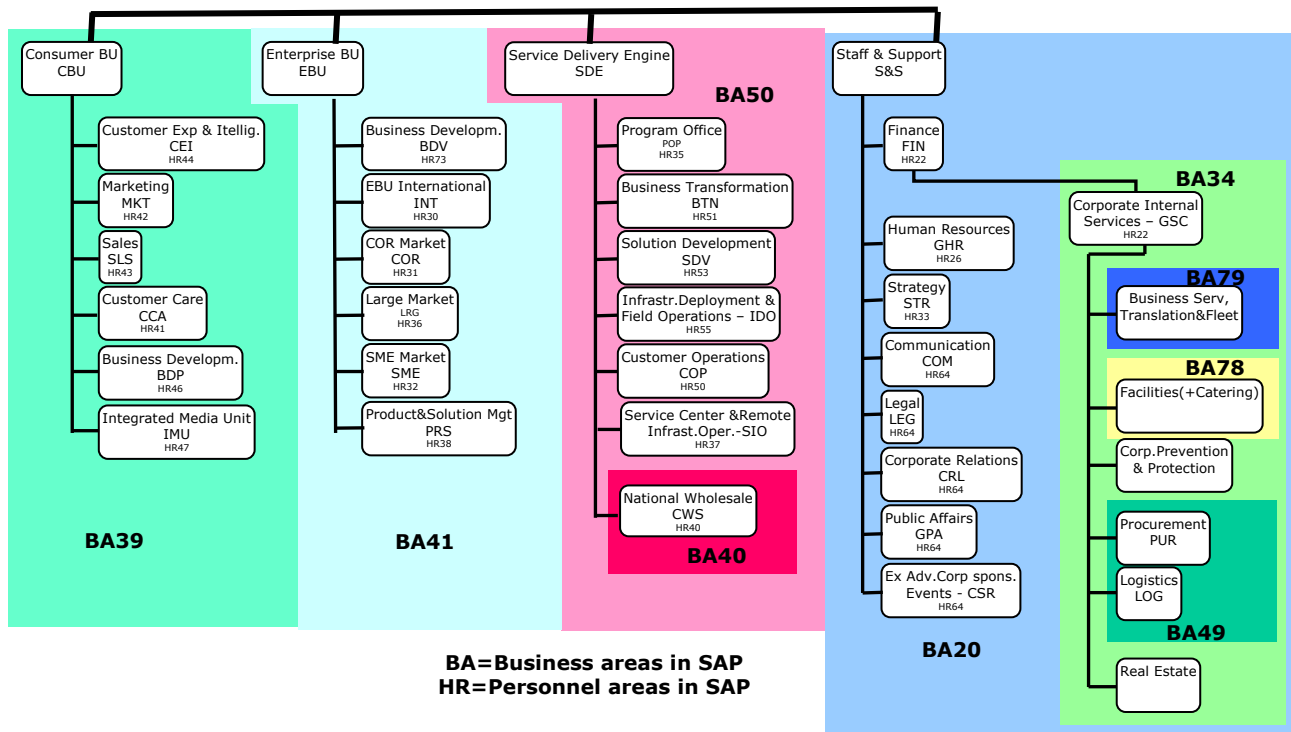

This document describes the costing and allocation methodology of ITN-COP CAPEX and OPEX resources.

The first chapter introduces cost concepts. The costs incurred by ITN are introduced in the first section of this chapter, where the link between the model and the accounting books of ITN is stressed. Ways to re-evaluate the network assets in current cost accounting are further introduced.

In the second chapter the concepts defined in the first chapter are put into practice. The chapter starts with an overview of the general principles of the top down model.

The third chapter describes the network and IT operational costs.

The next chapters illustrate how costs have really been allocated within and among the five network layers, i.e. access, switching, fibre infrastructure, backbone and data. Each layer has its own specific rules to attribute its costs.

In the last chapter an overview is given of the IT CAPEX cost allocation stream.

7.2 *Cost Base in the Network & IT cost model*

7.2.1 **Cost categories**

The Network & IT top down model considers all costs directly linked with the network and with the IT infrastructure, platforms and software. These costs include all investment costs of the network infrastructure and the IT infrastructure as well as operational costs (OPEX) of the network staff, of the IT staff, the material out of stock costs and those related to outsourced services.

The model also addresses costs indirectly linked with the network and with the IT infrastructure: these are support costs related to building, fleet, power chain, catering, purchasing, warehousing.

7.2.1.1 *Direct costs*

Depreciation costs and Capital costs:

These are the investment costs; non-cash costs covering the depreciation of assets of the network and of the IT infrastructure and applications as well as the yearly capital cost .

These costs are based on the accounting books of Belgacom where different asset classes are defined. The model cost base is built on the same asset classes however two different treatments are applied depending on the domain of assets:

- for the network assets, a Gross Replacement Value is computed, and further an annual cost is derived based on an economical depreciation method
- for IT assets, the depreciations of the current year from the accounting books are used as well as the net book values.

Note that depreciation costs also include some costs incurred by other divisions.

Direct operational costs:

Labour costs: cash costs covering salary and wages for Network and IT staff. A part of the labour costs are capitalized².

Material out of stock (MOS): cash costs covering the items fetched by Network personnel from the stocks. Items can be further classified into office furniture, transmission, switching equipment, data equipment , clothes... A part of the MOS costs are capitalized.

Services and other goods (S&OG): cash costs covering invoices paid to third parties for the receipt of services or goods. Typical examples of these costs are:

² A part of the labour costs are produced fixed assets (PFA). These costs are mapped on the relevant assets based on the description given by Network & IT personnel. Typically, installation costs are PFA. The reason for this is that an equipment cost does only cover the price paid to the supplier to get the right hardware and software in pieces. At this point the equipment can not yet yield anything unless it is installed and integrated in the network. Hence installation costs are produced fixed asset and as such are depreciated.

- consultancy,
- outsourcing (e.g. to dig trenches in the area, maintenance contracts),
- consumable purchases (e.g. clothes, office material, paving material, etc.),
- research contracts (e.g. with universities),
- GSM bills
- etc.

The direct operational costs are those incurred by Belgacom during the year and are extracted from the accounting books from a variety of GL accounts.

The accounting books of Belgacom SA register all incurred costs per cost center. Cost centers identify each a part of Belgacom SA organisation; there are 489 different cost centers and they are hierarchically structured so as to fit to the operational organisation.

The Network & IT direct cost base is determined by the combination of the cost center and the GL account denomination: the cost center information item to capture those parts of the organisation that are network related and IT delivery or infrastructure related, the GL account denomination item to capture the network related or IT delivery and infrastructure related cost sources.

The following teams (IT&N and COP) constitute the total direct OPEX cost base of the model:

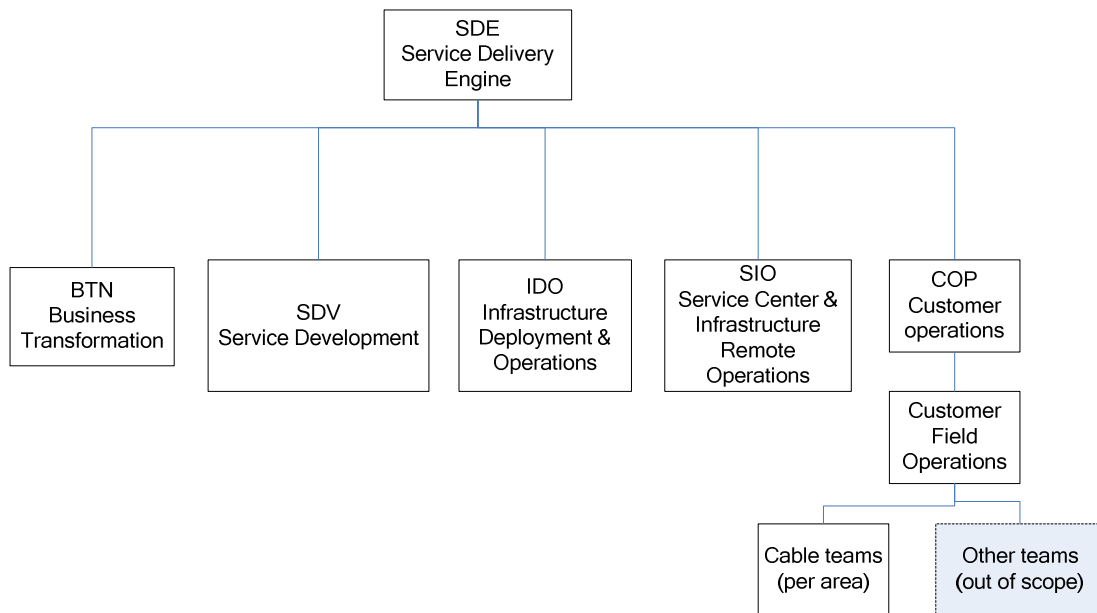

7.2.1.2 Indirect costs

Support costs: these are the total costs incurred by non network and non IT departments but which support the core activities of the network and of the IT departments.

The divisions / departments contributing to these indirect costs are Infrastructure & Facilities Management (IFM), Real Estate Management (REM), Business Services and Fleet (BSF), Corporate Sourcing and Supply Chain Management (CSM), Catering services (CTR) and FIN (accounts payable).

These divisions/departments deliver services like

- *Buildings:* costs linked to technical and office rooms.
- *Fleet:* costs linked to the cars and vans used by network and IT personnel, both utility and management cars.
- *Purchasing:* costs linked to the handling and the follow-up of orders.
- *Warehousing:* costs linked to stock management.
- *Power chain:* costs linked to the delivery of energy to office buildings and technical buildings.
- *Catering.*

The use of some of these services is shared with other divisions.

7.3 *Methods used to reevaluate the network assets*

The regulatory framework clearly states that the cost accounting systems of operators being declared as dominant on relevant markets must be set based on Current cost accounting for the network costs.

The network & IT top down model ppp2008 therefore calculates current costs for the network related assets. Current costs have been computed as explained hereafter.

There are five methods to evaluate the current value of the network: reassessment of the current inventory, price indexation, by default “keep everything as it is”, and regulated cost price based. For old assets concerning technology still in service we use a new method based on a fixed PPC2007. Each of these methods requires its own set of inputs. It is mainly the availability (or lack) of input which dictates the choice of the method. Nevertheless each method has its advantages and disadvantages with respect to the others.

The inventory and price indexation methods assume that network departments replace the equipment of its assets by equivalent equipment. The notion of equivalent is quite fuzzy. An engineer would tell you that over time there are always more functions integrated in new equipment and that they are always more cost-effective. It makes the comparison between different generations of equipment difficult. The notion of equivalent has therefore been addressed through the term Modern Equivalent Asset (MEA). The assets must be replaced by their MEA. The MEA is the replacement cost of the technology expected to be in place within the planning horizon. Note that this notion takes into account the introduction speed of a new technology in the network. If network departments plan to have replaced 50% of an old technology by a new one within the planning horizon, it makes no sense to simulate the costs with higher percentages because the planning takes into account the availability of the resources to carry out the work.

Find hereafter the rules that have been used:

- ❑ Technology still in procurement: use current price, e.g. SDH equipment, DWDM equipment
- ❑ Technology to be replaced within the planning horizon: use current price of the modern equivalent asset, e.g. some PDH line system equipments are replaced by SDH equivalents.
- ❑ Obsolete technology: use current price of the modern equivalent asset, e.g. the HDSL technology for high speed services on copper replaces the less cost-effective HDB3 technology.
- ❑ Technology grouped in: those assets will be revaluated by another asset concerning the same technology
- ❑ Old technology not anymore in service: those assets are set out of scope and will not be revaluated
- ❑ Old technology still in service (in maintenance mode); those assets are revaluated by an index method based on a fixed PPC instead of index or inventory method. Old assets revaluated by keep will keep the CAV value as GRC
- ❑ ATM technology: use the BIPT regulated cost price to value the switching component of asset.

7.3.1 Price Indexation

This is the most straightforward approach, provided historical costs are available. The investments for each year (from 1981 on) are multiplied by the price index of the year concerned. The price index is equal to the ratio of the current price to the historical price of the equivalent service/product.

The method is refined by defining price indexes depending on the nature of the cost. This is particularly true when costs of a different nature experienced a different price evolution. Typically, the labour index keeps growing while the equipment indices tend to decrease. Three different types of price indices have been defined: the labour index, the indices for services delivered by external companies and the material index. Note that indices for services supplied by external companies vary according to the asset involved. For example, services supplied by external companies related to cable assets, are in fact outsourced labour costs for trenching and cable installation. In such case, a labour index has been applied. Other external services less labour intensive are resulting in other price indices, such as a fibre cable index.

7.3.2 Inventory

This is the best method to reflect accurately the price of assets currently in service in the network. The revaluation is merely performed by multiplying the volume of each specific type of equipment currently deployed in the network by its average current unit cost. The current unit costs are based on the prices defined in the current frame agreements we have with our suppliers.

In terms of inputs it is the most demanding method. It requires an extensive inventory of equipment.

The inventory method has been used for data, switching, transmission and access equipment. Switching data is based on the inventory reports delivered by the engineering service. Transmission and access data are obtained from the technical database ITR. Data inventories are obtained from field operational tracking sheets.

7.3.3 Keep as it is.

The “keep as it is” method is merely what its name says. We keep the price we have in the historical accounting books. This method is only valid for costs with a very short depreciation period or for software intensive products. For the latter we assume that on the one hand software development is labour intensive but on the other hand the rapidly evolving programming environment improves the productivity compensating for the higher labour cost. This results in a stable software price. Another practical reason to select the “Keep as it is” method is the amount booked on the asset. If this amount is small, the method has also been applied. In this particular case, the effort to collect all the information about the cost evolution outweighs the impact on the service costs.

7.3.4 Index Based on a fixed PPC

Old technology still in service (in maintenance mode); those assets are revaluated by an index method based on a fixed PPC.

If Belgacom has done some investments for keeping those technologies in service, we take those investments also into account.

□ Formula:

$$GRC_{yearN} = [(GRC_{yearN-1}) * (1 + fixedPPC2007)] + investments_{YearN}$$

7.3.5 TAM: Tilted Annuity Method

7.3.5.1 Theory

The purpose of this section is to describe how the Tilted Annuity Method (TAM) is finally implemented in the Current Cost Accounting (CCA) based network cost model 2008.

The white paper “Treatment of fully depreciated assets in the calculation of interconnect costs” of Analysys mentions 2 formulas for calculating annual CAPEX by making use of TAM:

Exhibit 4, p. B2

Exhibit 5, p. B3

In the 2001 & 2002 PPP models, Belgacom has chosen for the formula of Exhibit 5, p. B3. However, as from PPP2003, Belgacom implemented the formula that BIPT suggested.

$$ACC_{\mu Y} = F1, \mu Y \times F2, \mu Y$$

where

$$F1, \mu Y = (GRC_{\mu Y, \text{begin}} + GRC_{\mu Y, \text{end}}) / 2$$

$$F2, \mu Y = \sqrt[3]{(1 + WACC_Y) \times [1 - (1 + APC_{\mu}) / (1 + WACC_Y)] / [1 - [(1 + APC_{\mu}) / (1 + WACC_Y)]^{L_{\mu}}]}$$

and where

- $ACC_{\mu Y}$: Annual CAPEX Cost of asset μ and year Y . It includes the annual depreciation and the cost of capital.
- $WACC_Y$: WACC of year Y .
- $GRC_{\mu Y, \text{begin}}$: Gross Replacement Cost of asset μ at the beginning of year Y .
- $GRC_{\mu Y, \text{end}}$: Gross Replacement Cost of asset μ at the end of year Y .
- APC_{μ} : Annual Price Change of asset μ .
- L_{μ} : Lifetime of asset μ .

Remarks:

The formula assumes that:

- In the beginning of year Y was invested in an asset and that at the middle of each year of the lifetime of the asset revenues will be generated.
- The annual price change is constant over the lifetime of the asset.
- The asset price does not evolve during the year, i.e. price changes only appear at January 1st.

The factor $F1, \mu Y$ represents the value of asset μ in the middle of year Y .

- The purpose of the arithmetic average of $GRC_{\mu Y, \text{begin}}$ and $GRC_{\mu Y, \text{end}}$ is to take into account investments or disinvestments of asset μ during the year Y .
- The arithmetic average of $GRC_{\mu Y, \text{begin}}$ and $GRC_{\mu Y, \text{end}}$ does not filter out the price evolution of the asset μ during the year Y .

The difference between the formula of BIPT and the formula of Exhibit 5, p. B3. of the white paper of Analysys is the factor $1 / \sqrt[3]{(1 + APC_{\mu})}$, which filters out the price evolution of the asset μ during the year Y .

The gross replacement cost (GRC) of assets at any particular point in time is calculated as the sum over all assets owned by the business at that point in time, of the investment that would be necessary to purchase and install new replacements for those assets at that point in time (using modern equivalent assets if the existing assets are no longer available or efficient). The replacement value of assets, used for costing purposes should always include the gross value of every asset in use by

the business (the current cost of replacing it with a new, possibly modern equivalent asset), irrespective of the history of depreciation of that asset in any financial accounts to date.

L_{μ} : Lifetime of asset μ , i.e. the expected useful lifetime of the new asset μ .

The depreciation period and the expected useful lifetime of a new asset are defined differently. The depreciation period refers to accounting. The expected useful lifetime of a new asset does not refer to accounting. It refers to the period that is expected that a new asset will be used. The main factor to determine the expected useful lifetime of a new asset is the evolution of the associated operational costs, i.e. the asset will be replaced when operating becomes too expensive. Another factor is the appearance of new technology: if in the future new technology will come-up it could be that the asset will be replaced (even if it is not too expensive to operate).

7.3.6 Regulated cost price based asset valuation.

In 2008, the valuation of the ATM asset has been aligned with the BIPT BROBA model 2008.

In the ATM network architecture two levels of ATM switches are present: the local ATM switch, and the area level ATM switch, the area level nodes correspond to the interconnect areas used in BRIO, BROBA and BROTSOLL. The function of the ATM network is to provide switched Virtual Paths between a port of a local switch and another port of the same local switch (local VPs) or of an area switch (nonlocal VPs). For Virtual Path switching two equipments are involved: the ATM switches themselves (also called switching fabric), and the trunk interfaces to interconnect distant ATM switches. In order to access configured Virtual Paths, access interface equipments are needed at the border of the local or area switches.

The ATM asset contains the investment costs of the equipments delivering switched Virtual Paths (ATM local switches, the ATM area switches, the ATM trunk interfaces for the backhaul links between the ATM switches) and the equipment delivering access to VPs (ATM interfaces for the ATM tributaries or clients).

The costing of the asset is thus decomposed in the costing of the VP switching equipment (backbone ATM equipment) and in the costing of the access to VP equipment.

7.3.6.1 CAPEX Costing of the VP switching component

This costing is based on the inventory of switched Virtual paths (local VPs, and non-local VPs) configured on the Belgacom ATM network. Each virtual path is valued using the BIPT BROBA VP tariffs 2008. Indeed, the BIPT tariffs are cost based and are established using a bottom-up costing model.

However, the BIPT tariffs being full cost tariffs, they integrate the ATM CAPEX, the ATM OPEX, the backhaul transmission costs (links between the ATM trunks interfaces), the IT costs and the overhead costs. Applying directly the BIPT BROBA tariffs would incorporate costs other than ATM CAPEX costs in the ATM asset. Therefore the costing is conducted in 3 steps:

The first step eliminates the IT, the overhead and the backhaul costs component from the BIPT tariff computing a tariff structure free of IT/overhead/backhaul. The second step applies this tariff to the inventory of VPs yielding ATM costs containing ATM CAPEX and ATM OPEX. The third step calculates the OPEX costs corresponding to the network equipment amounts allowing the VPs of the inventory and subtracts this cost from the ATM CAPEX&OPEX. The end result is an estimation of the pure CAPEX cost for all configured VPs.

There are many advantages in using this approach; first, the BIPT BROBA tariffs per VP value complex VP characteristics like Quality of Service, Peak Cell Rate / Sustained Cell Rate ratio, distance aspect (local, nonlocal VPs) and VP capacity. Secondly, the BIPT tariffs also value other material costs directly involved in ATM like cabling investment costs and ATM management platform investment costs.

7.3.6.2 CAPEX Costing of the ATM access component

The CAPEX costing of the ATM access component is based on the detailed inventory of access lines ending-up in ATM switches; the source of this inventory is the ITR infrastructure inventory system. Only the tributary lines are considered in this inventory as the accesses for ATM interswitch links (trunks) are already valued in the VP switching component.

The same unit costs of ATM ports as in the BIPT Bottom-Up BROBA are applied on this inventory depending on the capacity of tributary line to come to the CAPEX costs of the ATM access component.

8 Network & IT Fully Allocated Cost Top Down Model

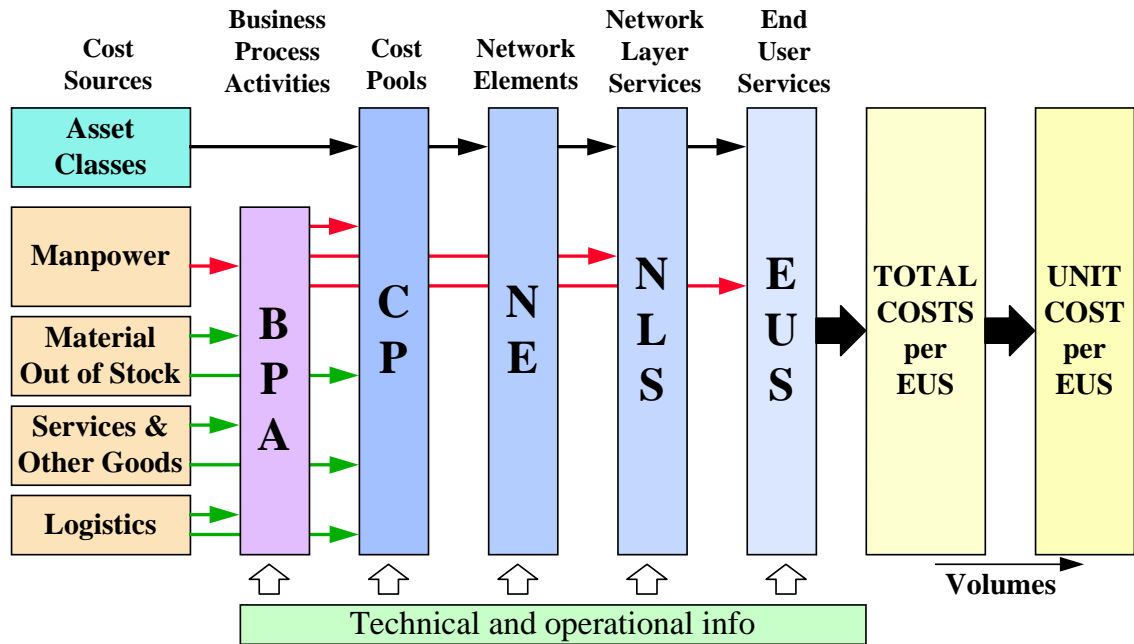

8.1 Introduction

The aim of the PPP Fully Allocated Cost (FAC) model is to allocate all the known (historic) investment costs as well as the operational costs, to the various services which are offered by Belgacom to its customers (both internal and external), by defining a causal relationship between the general ledger and the end user services (Figure 2-1).

Since the basic network infrastructure is used by a variety of services, a number of allocation keys is determined to distribute its cost between the services. These allocation keys are based on the usage of the network infrastructure by each service, which can be determined by using the information available in the technical databases. The model provides for each service a detailed cost structure, i.e. for each service the model provides the contribution of the different asset accounts, operational activities, materials out of stock, service and other goods, to its cost.

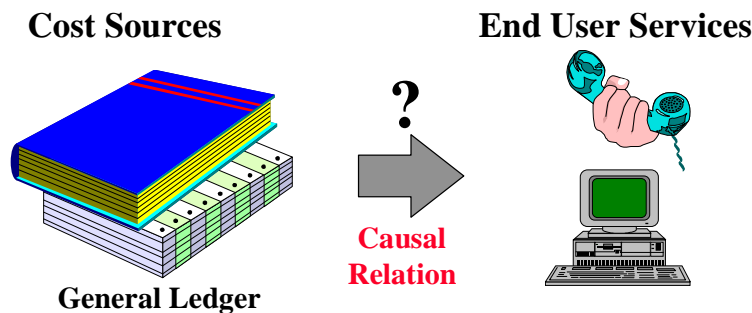

Figure 2-1 The objective of the FAC-Model

Full Cost Allocation implies that all direct service costs, as well as a part of the common costs, are allocated.

8.2 Basic components of the model

8.2.1 Cost Sources

Information Technology and Network departments can be considered as a company offering end user services to its clients. To deliver these services IT&N departments invest in network and IT infrastructure, where the investments are characterised by the annual depreciation and the remaining net book value. Of course the network and IT infrastructure needs to be operated in order to deliver these services. For this purpose the network and IT departments rely on material and services & other goods delivered to the company, as well as the available manpower and logistics within the company (Figure 2-2).

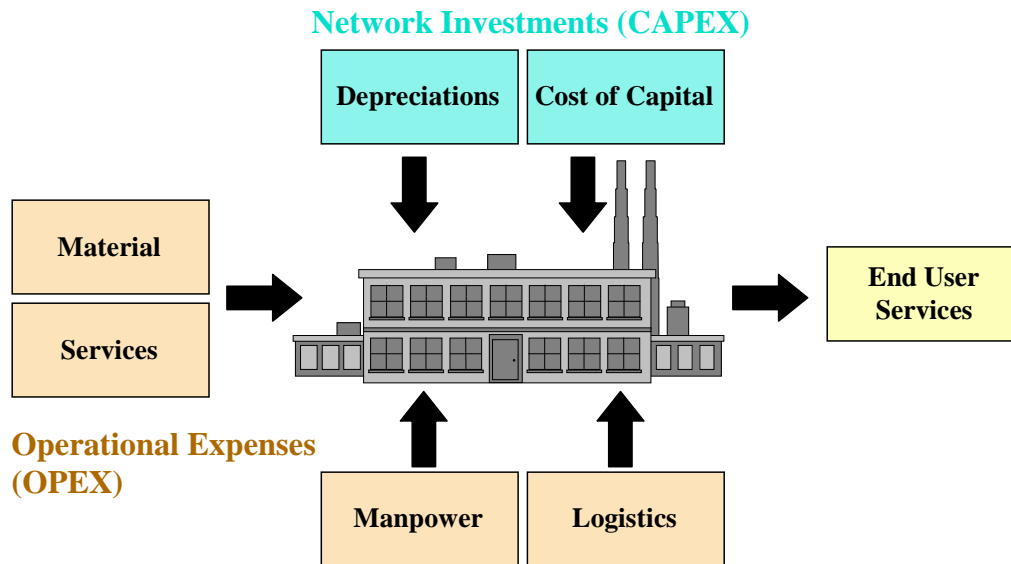

Figure 2-2 Cost Flows

8.2.1.1 CAPEX

The data concerning the CAPEX in the network (annual depreciation, net investment value,...) is contained within the asset accounts. The model notably uses the asset accounts from:

- IT&N (Information Technology and Network): (AC1xxx-AC2xxx)
- EBU (Enterprise): (AC6xxx)
 - transmission equipment installed at the client's premises (e.g. SYRAR, routers)
 - equipment used for the data network (e.g. ATM switches, X25 switches, ...).

8.2.1.2 OPEX

The data concerning the OPEX in the network and IT domains are taken from the SAP GL accounts data.

8.2.2 Cost components: definitions

8.2.2.1 Cost Pools

A number of Cost Pools (CP) is identified, where each cost pool represents an aggregation of cost sources from the general ledger (both depreciation and operational expenses). A cost pool typically represents:

- a type of equipment (e.g. SDH Add Drop Multiplexer)
- a type of cable (e.g. interzonal optical fibre cable)
- the cost of a network management system (e.g. the SDH network management system)
- etc...

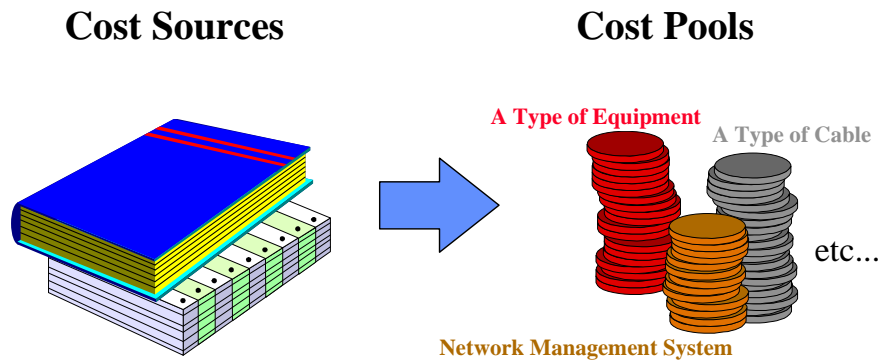

Figure 2-3 Cost Pools

8.2.2.2 Network elements

The Network Elements (NE) can be considered to be the building blocks of which the network infrastructure is composed. They represent the different types of cables in different parts of the network (Figure 2-4), and the different types of equipment to be found in the network nodes (Figure 2-5). These network elements can be related directly to the data entities in the technical infrastructure databases, so that the degree by which they are used by the various services can be determined.

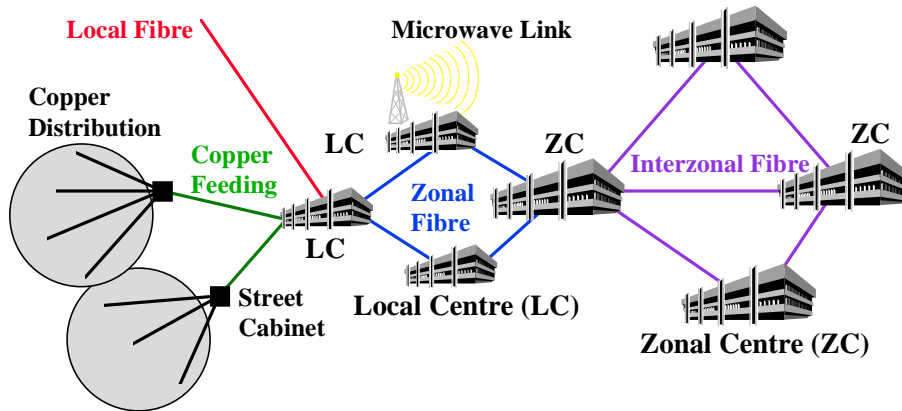

Figure 2-4 Network elements: types of cables

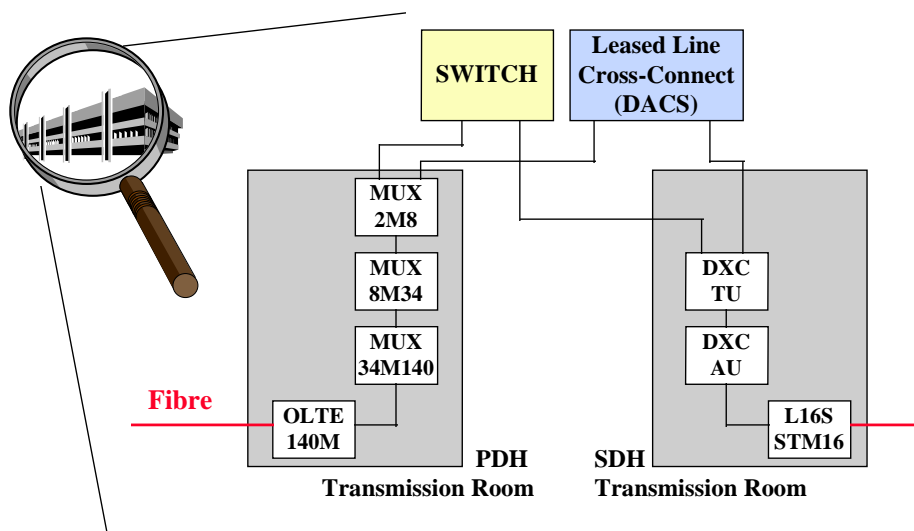

Figure 2-5 Network elements: equipment in network nodes

In many cases there is a one-to-one relationship between a cost pool and a network element, in particular when the cost pool corresponds to a type of equipment or a type of cable. Some cost pools however, are allocated to a series of network elements.

8.2.2.3 Network layer services

A Network Layer Service (NLS) is a service offered by one layer of the network contributing to either a network layer service in another layer of the network, or to an End User Service (EUS). We distinguish 4 layers in the network: the access layer, the backbone layer, the switching layer and the data layer. The access layer and the backbone layer will deliver the basic network layer services to the switching layer and the data layer. The trunk lines between switches for example are realised through 2Mbit/s transmission systems in the backbone network. Hence we can say that the network layer services “Zonal 2Mbit/s Transmission System for Switching” and “Interzonal 2Mbit/s Transmission System for Switching” in the backbone layer are services offered to the switching layer, which contribute to the cost of the switching trunk network (Figure 2-6). The cost of Network Layer Service is determined by the network elements it uses.

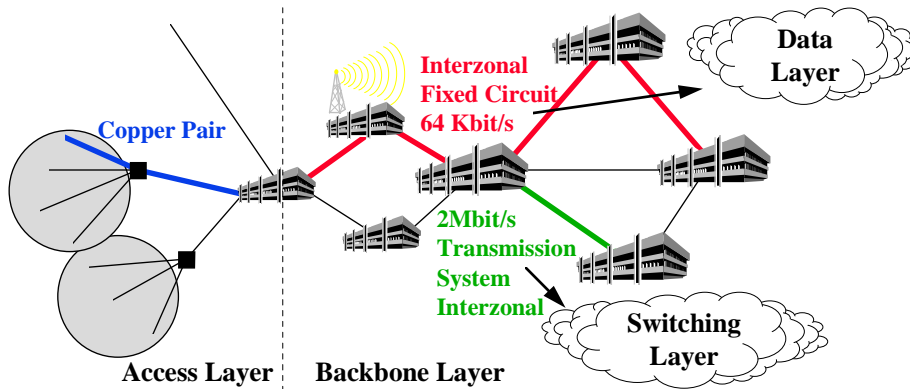

Figure 2-6 Network Layer Services

8.2.2.4 End user services

The End User Service (EUS) represents the service offered to the client. It is composed of at least one network layer service. The cost of for example the End User Service “Leased Line 64Kbit/s” will be composed of the cost of its route in the backbone network, represented by the Backbone Network Layer Service “Fixed Circuits 64Kbit/s”, the cost of the customer access line, represented by the Access Network Layer Service “Copper Access Line” (Figure 2-7) and the cost of the network termination equipment. We distinguish subscription EUS and provisioning EUS, where the subscription EUS reflects the annual cost of an EUS, and the provisioning cost the one-shot cost to provision the service, i.e. to connect the client.

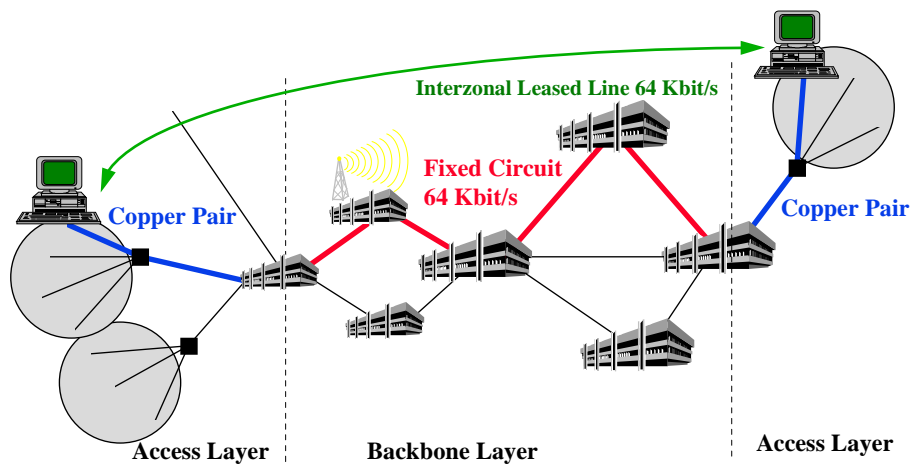

Figure 2-7 End User Services

8.3 The Fully Allocated Cost Model (FAC)

The starting point for the product costing is a fully allocated cost model. In a first step the commercial end products, the end user services, of which the cost will be determined need to be defined. About 200 end user services have been distinguished. Then, the input costs need to be categorised. We distinguish 4 main financial inputs:

- **Asset Classes:** These contain the depreciation and the Weighted Average Cost of Capital of the network investments. See the chapter of the Tilted Annuity Method. Note that the asset classes also contain the Produced Fixed Assets (PFA), i.e. the manpower and Material Out of Stock (MOS) linked to the investments.
- **Manpower:** This category represents the wages spent on the different activities within Network and IT departments. Note that this corresponds only to the wages related to operational processes, such as maintenance (both preventive and reactive), and provisioning, and support activities (PFA not included).
- **Material Out of Stock:** This is the cost of the material taken out of the stock in the execution of various operational processes (e.g. maintenance, repair).
- **Services & Other Goods:** This category represents the invoices paid to third parties in relation to operational processes (e.g. maintenance contracts).

The main part of the model consists of establishing causal relations between the cost sources and the end user services. The causality is reached by following Building Block Costing (BBC) for the costs related to the network infrastructure, and Activity Based Costing (ABC) for the costs related to the operational activities. To keep the model transparent, we opted for a layered approach as depicted in Figure 2-8.

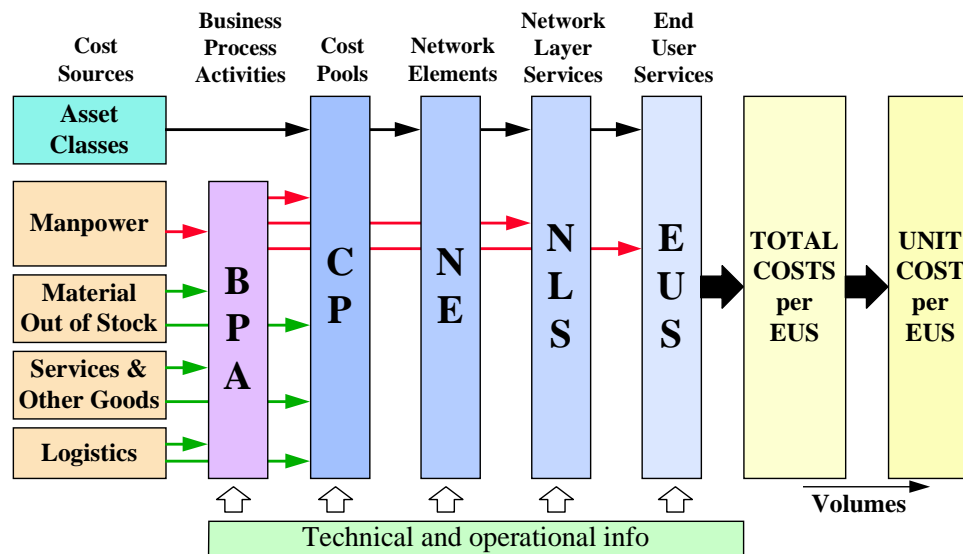

Figure 2-8 PPP FAC Model

8.3.1 Network Infrastructure Costs

The costs related to the network infrastructure, being the annual depreciation and the Weighted Annual Cost of Capital on the network asset classes, are allocated to the End User Service through a **Building Block Costing (BBC)** method. In the FAC-model the building blocks have been denominated Network Elements, which are associated to cost pools.

8.3.1.1 Cost Pools

In a first step of the BBC-procedure, cost sources such as asset accounts (or parts of asset accounts) are mapped onto cost pools. A cost source can be either allocated for 100% to a cost pool, or it can be distributed over more than one cost pool. The latter case occurs for example when different types of equipment are booked onto the same asset account.

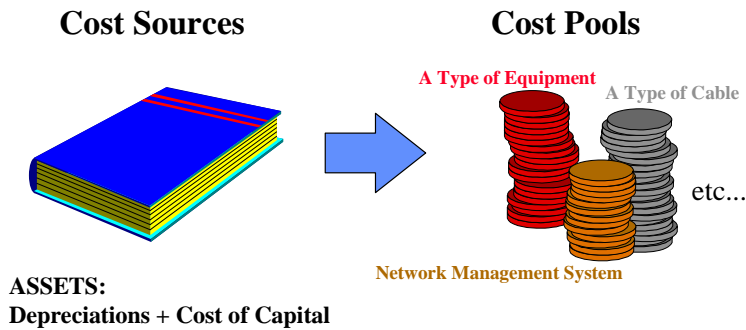

Figure 2-9 Asset Classes - Cost Pools

To split cost sources into different cost pools, cost drivers need to be identified. To split the fibre cable assets into a cost pool for access fibre cables and a cost pool for backbone fibre cables, the drivers will be length and size (the number of fibres in the cables), since the cost of a cable is determined by its length and its size (Figure 2-10). For the cable trenching costs, only the length will be the driver. To split assets containing more than one type of equipment into cost pools (one for each type of equipment), the number of equipment and the unit cost per equipment type are the drivers used.

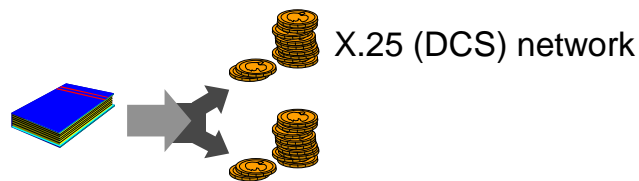

Figure 2-10 Asset Classes - Cost Pools: example 1

Although there may be a certain degree of detail available on asset level, this detail is not always representative. To give an example, for historical reasons there are various switch accounts, such as an asset account for the switch access line cards, an asset account for the switch core, and an asset for the switch trunk cards. Now that the contracts with the vendors have changed, and the price of the switch core is included in the price of the line cards, it is not possible any more to make the distinction between the cost of the core and the cost of the line cards, such that the switch invoices are booked onto one asset only. Therefore we can not base ourselves onto the split between core and line cards on asset level, since it is not correct. And for that reason these various switch asset accounts will be aggregated into one switch cost pool (Figure 2-11).

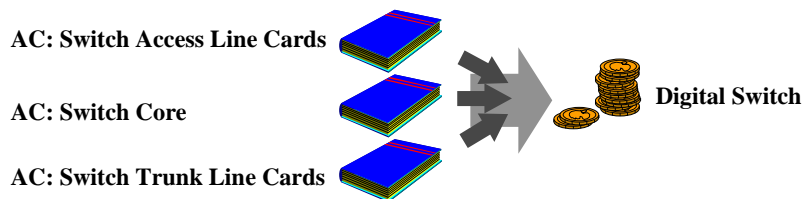

Figure 2-11 Asset Classes - Cost Pools: example 2

8.3.1.2 Network elements

The physical network parts and the related cost pools are split into network building blocks, which we have called “network elements” (Figure 2-12).

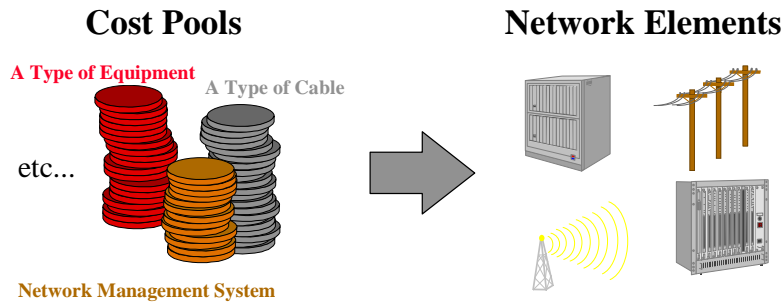

Figure 2-12 Cost Pools - Network Elements

They represent the different types of cables in different parts of the network (e.g. local copper cable, access fibre, backbone fibre,...), and the different types of equipment to be found in the network nodes (e.g. Line Termination Equipment, PDH Multiplexors, SDH Line Systems, Add Drop Multiplexors, Digital Cross-Connects, etc...). In many cases there is a one-to-one relationship between a network element and a cost pool, in particular when the cost pool corresponds to a type of equipment or a type of cable.

Some cost pools however, are split into a series of network elements. Typical examples are the cost pools representing the network management system costs. The cost of a network management system, such as SDH mediation devices for the SDH-network, is allocated to the equipment, i.e. network elements, monitored by the management system. For SDH the Digital Cross-Connects AU (DXC-AU: 140Mbit/s) and TU (DXC-TU: 2Mbit/s), as well as the Add Drop Multiplexors (ADM), are the network elements concerned (Figure 2-13). The drivers are the number of network elements managed and the complexity factor per network element. The latter driver is used to take into account that the management of a DXC for example requires more resources from the management system than an ADM.

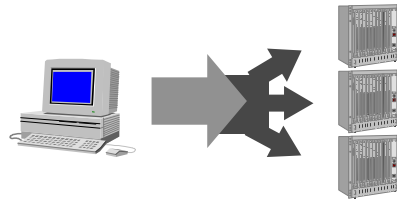

Figure 2-13 Cost Pools - Network Elements: example

8.3.1.3 Network Layer Services

The next phase in the cost allocation process captures the usage of the network elements by the network layer services, using the technical information from databases such as ITR. The relation between network layer services and network elements, expressed by allocation keys, indicates to which degree particular network elements (cables, various types of equipment) are used by each NLS. The cost drivers determining these keys can be:

- length: for fibre cable network elements
- capacity (e.g. number of fibres used, number of timeslots used, ...): for fibre cable network elements, Digital Cross-Connect network elements, etc...
- number of equipments used: the number of elements through which a network layer service is routed on average.
- number of calls: IN-platform network elements
- minutes (call duration) combined with routing factors: traffic sensitive part of switch, trunk card network elements

The NLS “2Mbit/s Transmission Systems for Switching” for example, will be assigned part of the cost of the backbone fibre cables (the cost drivers are the number of fibres used and their length), as well as part of the transmission equipment, both PDH and SDH (pro rata the usage of these systems). The same applies to the NLS “Fixed Circuits 64Kbit/s”, since the backbone transmission infrastructure is a common infrastructure used by most services, though in addition this NLS will receive a cost contribution from equipment such as DACS (cross-connect on 64Kbit/s level) and SMUX (multiplexor, multiplexing 64Kbit/s, 128Kbit/s signals into a 2Mbit/s system) (Figure 2-14). The example illustrates that the routing in the network, and the multiplexing efficiency, i.e. the filling rate of the transmission systems, are reflected in the cost structure of the network layer service.

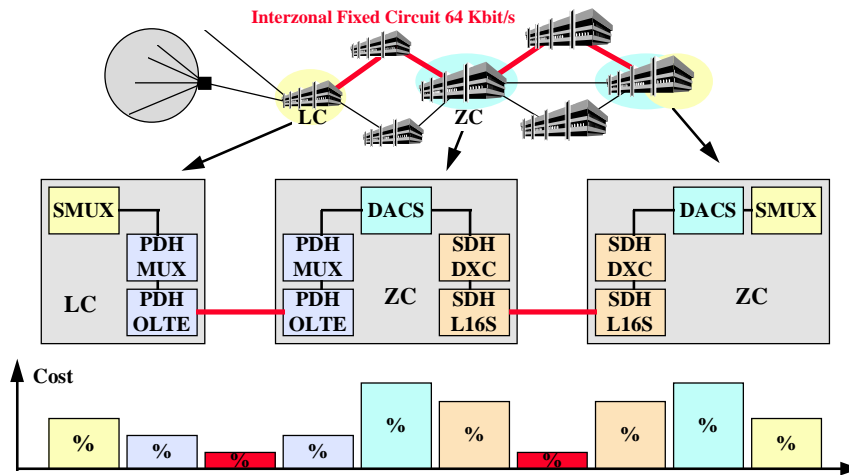

Figure 2-14 Network Elements - Network Layer Services

NLS/NE	MUX 2M8	MUX 8M34	MUX 34M140	OLTE 140M	L16S STM16	DXC AU	DXC TU	ADM	DACS	SMUX
Zonal 2Mbit/s Switching	X1 %	Y1 %	Z1 %	A1 %	B1 %	C1 %	D1 %	E1 %		
Interzonal Fixed Circuit 64Kbit/s	X2 %	Y2 %	Z2 %	A2 %	B2 %	C2 %	D2 %	E2 %	S1 %	T1 %
Interzonal Fixed Circuit nx64Kbit/s etc...	X3 %	Y3 %	Z3 %	A3 %	B3 %	C3 %	D3 %	E3 %	S2 %	T2 %

Table 1 NLS/NE Allocation table

The NE-NLS allocation phase in the FAC-model, is actually made of 6 successive phases. These phases are needed:

- in order to combine access NLS and backbone NLS to constitute the end-to-end services at EUS level
- in order to correctly and causally account for management systems which themselves are often built on data networks; these data networks are in turn made of data nodes linked via transmission NLS.

Globally, the 6 phases can be described as follows:

NE -> NLS1: the main access NLS (PSTN/ISDN lines, xDSL lines, LL copper access lines), the main backbone transport NLS are constituted from the NEs contributing to them (2Mbs internal lines, data trunks, switching trunks, network management lines, network management services, leased lines, access to data etc.)

NLS1 -> NLS2: the network management lines and services are allocated towards the internal lines, the data trunks, the switching trunks, the leased lines in function of the number of NEs monitored by the management system and routing the lines under consideration.

NLS2 -> NLS3: the data trunks and the data nodes are combined to form the ATM network services (PVCs).

NLS3-> NLS4: the other services built using ATM network resources are constituted (xDSL, IP/VPN, network management network usually called DCN etc.).

NLS4 -> NLS5: the end-to-end management services are composed of the DCN and the OSS services.

NLS5-> NLS6: the management services are attributed to the data services, switching services they manage.

At this stage all network resources, OSS resources are causally attributed to the final NLS6 which are direct representations of most of the EUS services.

8.3.1.4 End User Services

In the final layer, the cost of the end user services (commercial products) will be composed of one or more network layer services (which can be considered to be technical products). Once the cost to be allocated to each End User Service has been determined, the unit cost per service can be derived dividing this cost by the volume of the EUS.

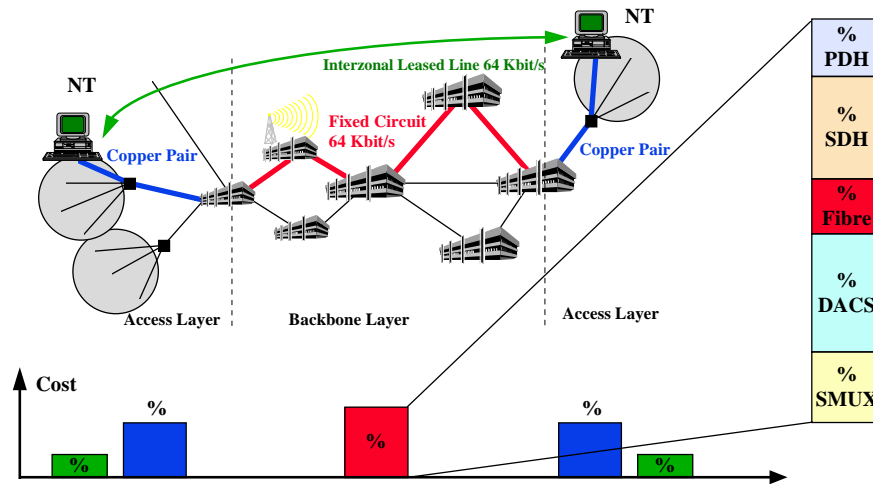

Figure 2-15 End User Services - Network Layer Services

The cost of a PSTN subscription for example will consist of the cost of the access line (NLS from access layer), and the cost of the subscriber sensitive part of the switch (NLS from switching layer). To the cost of PSTN traffic (per minute) will contribute the traffic sensitive part of the switch (NLS from switching layer) and the trunk network (NLS from switching layer, related to NLS from backbone layer). The cost of a leased line EUS will be composed of the cost of the access lines (NLS from access layer) if any, and the cost of a fixed circuit in the backbone network (NLS from backbone layer), as shown in Figure 2-15. The cost of the contributing NLS itself is composed of the contributions of various network elements as described in the previous paragraph.

So at the end, the contribution of the network element costs to the various end user services has been determined, through allocation keys which are based on technical and operational information (Figure 2-16).

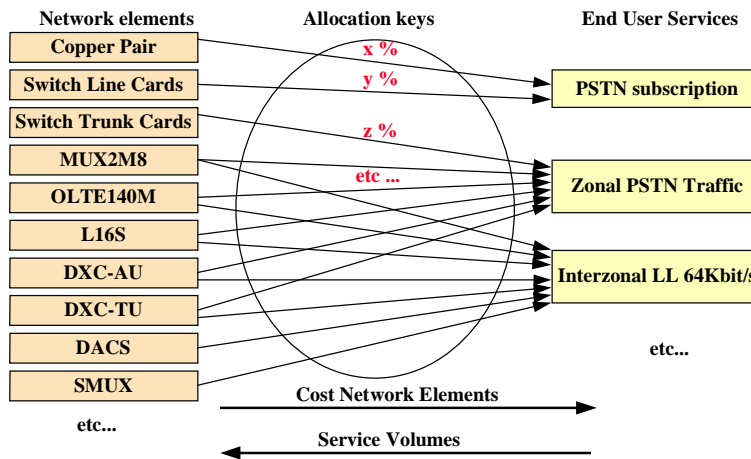
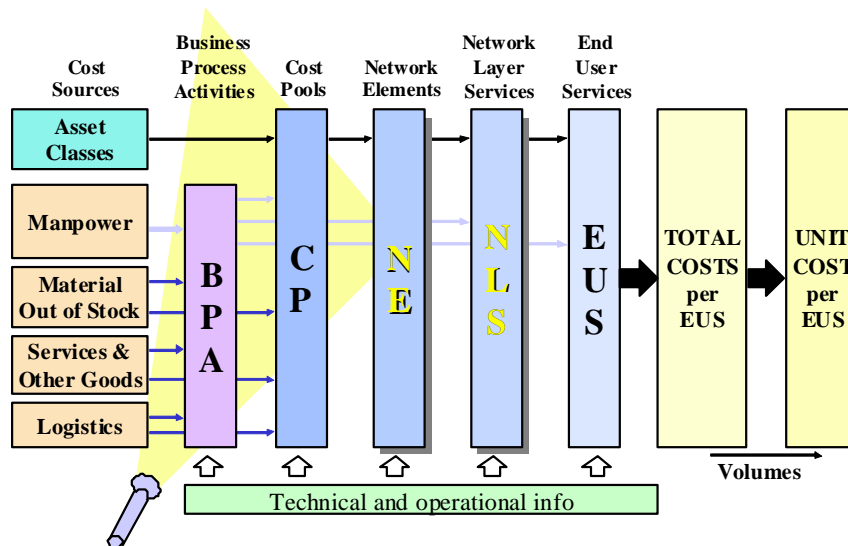

Figure 2-16 Building Block Costing (BBC)

9 The network and IT operational cost model



9.1 Cost objects

The ultimate cost objects of the operational cost model are classified as follows:

IT activity “7.2.5. Enhance, Maintain and Operate IT applications”: this activity consolidates all OPEX costs related to the enhancements of IT applications (non capitalized development mandays), to the proactive and reactive maintenance, planned interventions, configurations as well as all costs related to office automation hardware.

EUS: in some rare occasions, OPEX costs cannot reasonably be associated to a technology or technical platform but rather directly to a product (End User Services). This can be the case for IT pre-study costs in the context of new products which will not necessarily lead to developments on existing or new applications.

NLS1 (Network Layer Services –layer1):

e.g. NLS_X25D-channel: to aggregate technical OPEX costs related to the D-channel access service which cannot be related to more precise composites (NE) of the service.

CP1 or NE:

a variety of cost pools which are in a sense proto-network elements (cost pools gathering all equipment of a same technology indifferent to the role within the network) or a variety of Network elements.

AC2: a variety of asset classes pools used to aggregate costs directly related to assets (for example taxes on equipment).

PRIMARY ACT: these are all network activities defined within process 5 (Network Build & Maintenance). All these activities are allocated to network entities and collect HR driven costs (remunerations, small material consumption) corresponding to these activities.

9.2 *Common OPEX allocation stream IT and Network*

In the new ITN organisation, there are no distinct ranges for IT cost centers and Network cost centers. Thus, a same cost center may register IT costs together with non IT costs.

The first goal of the allocation stream is to separate all costs into IT specific costs and Network specific costs.

9.2.1 GL61 accounts – Services and Other Goods (SOG)

The GL accounts in the 61 range register outsourced maintenance costs as well as miscellaneous costs driven by staff (GSM, memberships, office material, internal events etc.).

The GL61 accounts were classified in two categories:

- those that may contain some manpower related consumption goods
- those that clearly do not contain manpower related consumption goods

Each of these accounts are split in different cost pools (pools per technology and pools for HR related costs) based on SAP detailed records.

9.2.2 GL62 accounts – Wages costs

The GL accounts in the 62 range register remuneration costs of salaried staff and manual workers, premiums, social security, bonus etc. Again, these costs are registered per cost center thereby mixing IT staff and non IT staff.

Step 1

The allocation stream of wages costs first aggregates the input data into two categories of cost pools (very similar to cost pooling in the ABC model but at the level of cost center): per level remuneration cost pools and corrective remuneration cost pools.

Step 2

The corrective cost pools are allocated to the per level remuneration cost pools.

Step 3

The per level remuneration costs are split over the ITN teamgroups based on the number of FTE of each level in each teamgroup. Indeed, to allow the separation of IT and non-IT remuneration costs, we need to drill down to the level of teams.

Step 4

A fourth step is introduced to “cascade” the costs of the overhead teams onto the executive teams managed by them. The output objects of these 4 steps are defined in the module “OperationalDriven_HR_CP”, each object being an executive teamgroup. At this point in the allocation stream a neat separation can be done between IT related costs (IT teamgroups) and non-IT related costs (non-IT teamgroups).

9.2.3 GL60 accounts – Material Out of Stock

The GL60 account costs cover the cost of all kinds of material taken out of the stocks of Belgacom and used for the repair of network or the cost of small items (office material, GSM,...) consumed by the staff in the context of their daily activities.

These accounts are split in different cost pools based on stock item information within SAP.

9.2.4 Allocation of teamgroups to activities

In a previous section, the allocation of manpower driven costs is explained ending in cost objects of module "OperationaldrivenHR_CP": these objects gather all the remuneration and HR driven costs per teamgroup of the ITN organisation.

The next allocation step aims at distributing these costs across the activities within the teamgroups. This distribution is based on the effort spent by each teamgroup on each activity. The definition of activities in the model depends on the effort registration system put in place. Different systems are used depending on the teamgroups within the organisation:

FTE templates: these are sheets to be filled in by team responsables.

A project and capacity management tool used within the ITN department by all employees.

The network activities are end cost objects of the Network and IT operational model. A reporting of the cost breakdown per cost nature of the network activities is used to derive the allocation keys of network related OPEX costs towards network activities in the other parts of the FAC model.

10 Top Down Copper Access Network Model

This chapter treats the Cost Pools (CP) and the Network Elements (NE) of the access network.

10.1 Basic components of the model

The first objective of the access network (AN) is the delivery of a connection between our customers and our telecommunication network where all services are implemented. The network boundary is in general the local exchange. As described previously, the network is made up of different network elements, its basic building blocks.

The first step of the modelling process is the mapping of assets onto cost pools. The second step maps cost pools onto network elements. The creation and definition of network elements and cost pools is dictated by the access network architecture.

Find hereafter an overview of the access network with its main network elements.

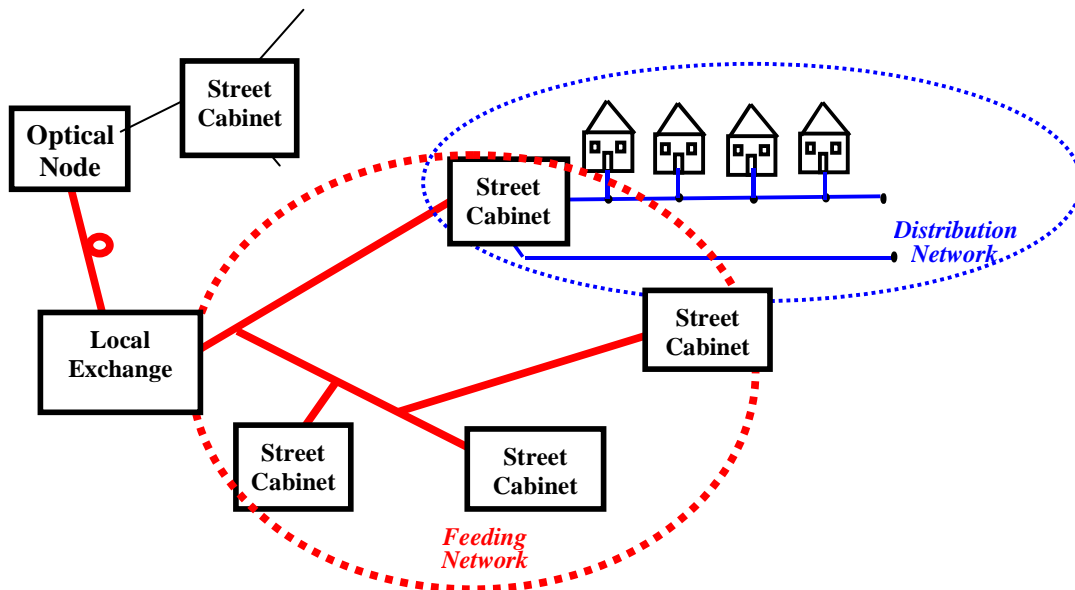

10.1.1 Cost Pools

The cost pools, with their respective definition, are listed in the next subsections.

The access network architecture is based on two main technical solutions¹ to connect customers to the local exchange: copper and fibre. No matter which solution is selected, there are three locations where equipment must be installed: at the local exchange, outside, and at the customer premises.

10.1.1.1 Customer premises equipment

- *NT1*

NT1 stands for Network Terminal 1. It is the termination device of an ISDN-BA connection. NT1 is a combined multiplexer and line system. It is no longer capitalized now, but there are still depreciation costs from historical investments. The cost driver is the number of ISDN-BA lines.

¹ There is a third one: radio links. They are documented in ITR and are attributed in the backbone model.

As the NT1 is only used by the ISDN-BA service, its allocation is straightforward to this service via the NE_NT1.

- ***Sub 2M systems and 2M line termination on copper***

Multiplexing equipment and line system mainly deployed for leased lines. It is able to groom several n*64kbit/s circuits into a 2Mbit/s.

- ***HSCU&VAM***

VAM stands for “Various Access Multiplexer”. VAM is a new generation of equipment combining the multiplexing and line system functions. It offers 1 or 2 64kbit/s circuits or 1 128kbit/s circuit.

HSCU stands for High speed Connecting Unit. Two equipments are needed at each extremity of the link to establish the connection. It is an older equipment offering the same range of services as a VAM.

Since no distinction is made in the assets, the HSCU and the VAM equipments are put together in the same cost pool.

10.1.1.2 Copper plant

- ***Metallic Line Testing***

Specific equipment, called “Teradyne”, tests the metallic lines carrying PSTN and ISDN-BA services.

- ***MDF***

MDF stands for “Main Distribution Frame”. It is a copper device located in the local exchange or in an optical node, and is used to manage the copper pairs. This is the first flexibility point of the access network. A customer is connected with a jumper linking its copper pair to whatever service (typically a switch).

- ***Pair Gain Systems***

A pair gain system (PGS) allows Belgacom to save copper pairs. Several PSTN or ISDN-BA lines are multiplexed to be carried on one, two or three copper pairs.

- ***xDSLequipment***

ADSL (Asymmetric Digital Subscriber Line) and SDSL (Symmetric Digital Subscriber Line) offer broadband access to the data platform.

- ***Cu-Feeding***

Copper feeding represents all the copper cables located between the local exchange or the local distribution centre (LDC) and the street cabinets.

- ***Street Cabinet***

The Street Cabinet is the second flexibility point of the network. It houses a copper distribution frame managing the connection between the feeding and distribution pairs.

- ***Cu-Distribution***

Copper distribution is the cable network starting from the street cabinet and following every street of Belgium.

- ***Copper Drop Segment***

The copper drop segment is the final copper section used to connect our customers. It is a small capacity cable (typically 4 wires) which is spliced on the distribution cable in front of the customer house and enters this house.

10.1.2 Network Elements

We describe hereafter the different NEs of the access layer in terms of CP combination:

10.1.2.1 Copper Drop Segment

This NE is made of the CP_Copper Drop Segment. Its allocation flow towards NLS is driven by the volume of each service requiring a copper drop segment in its provisioning process.

10.1.2.2 Local Copper Cables

Local copper cables are treated in 6 cost pools to distinguish usage by xDSL services and PSTN services.

- Pair gains avoid heavy investments in the feeding network
- Copper pairs freed thanks to pair gains can be used by any services (PSTN, ADSL, LL)
- Trigger for pair gains are local cable saturation

10.1.2.3 Copper Feeding, Distribution, Street Cabinet & MDF

NE_Cu-Feeding, NE_Cu-Distribution, NE_StreetCabinet and NE_MDF are made of the same cost pools as Local Copper Cables. Actually the only difference between local copper cables comes from historical reasons: these four NEs are allocated to classical services: PSTN and ISDN (and previously Telex) while local copper cables NEs are allocated to new services such as ADSL, raw copper,...

In order to avoid confusion between these four NEs and the local copper cables NEs, we add a suffix to their name:

- NE_Cu-Feeding_PSTN_ISDN_Telex
- NE_Cu-Distribution_PSTN_ISDN_Telex
- NE_StreetCabinet_PSTN_ISDN_Telex
- NE_MDF_PSTN_ISDN

10.1.2.4 NTI

This NE is the terminal equipment installed in the customer premise in order to send and receive ISDN-BA signals. It is fully allocated to the ISDN-BA services.

11 Top Down Fibre Infrastructure Model

11.1 Introduction

This chapter describes the allocation flow of the Fibre infrastructure from the Assets till the level of network element.

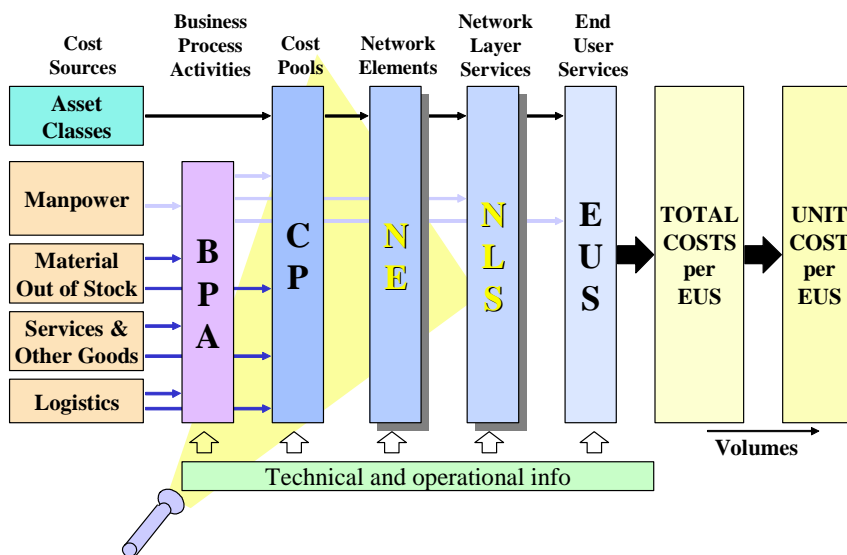

The Fibre (access or backbone) network elements represent an end to end optical medium suitable to convey optical signals (lambdas). They correspond to the “cable bundles” documented in the transmission inventory. Together with the copper counterpart, fibre bundles are the only network components spanning over two distant nodes and form the ingredient that grant telecom services to span over distant geographical nodes.

The fibre bundle network elements are “lengthy” objects in contrast to all other network elements in the model which are seen as being located in a node. These lengthy objects have a complex underlying structure including trenches, portions of cables, ducts, subducts and manholes. Cable bundles are realized between two node sites by splicing together several fibres in different portions of cables, which are themselves blown through different ducts (or subducts); subducts are placed or even blown through one or more ducts, the ducts are buried in one or several dig tracks. The tracks, ducts, subducts and cable portions are documented in the FIDGI inventory system.

11.2 Split of the trenching and the ducts investment costs.

Cost sources:

Because the FIDGI inventory database documents access as well as backbone fibre cable infrastructure, all assets related to ducts and trenching are put together in a common cost pool. In doing so, the cost pool amounts are in correspondence with the FIDGI data.

The CP_Trenching&Ducts cost pool gathers trenching costs which are km tracks driven as well as ducts costs which are cumulated pvc km driven. The duct costs are not directly track km driven because of the nested structure of ducts (microtubes/subducts/ducts). Because the cost drivers are different, the pvc costs and pure trenching costs need to be separated: and this is done based on the cost nature structure of the underlying assets:

Material Out of Stock are pure pvc costs, hence purely driven by pvc volumes.

Capitalized manpower and external invoices (outsourcing) are trenching costs, hence driven by km tracks.

Split of CP_Trenching&Ducts:

The cost pool is split into an access part and a backbone part; the access part is further decomposed in a Broadway part and in a non-broadway portion . The split keys are determined from the FIDGI inventory database and the investments on the Broadway project.

The resulting allocation flow is obtained:

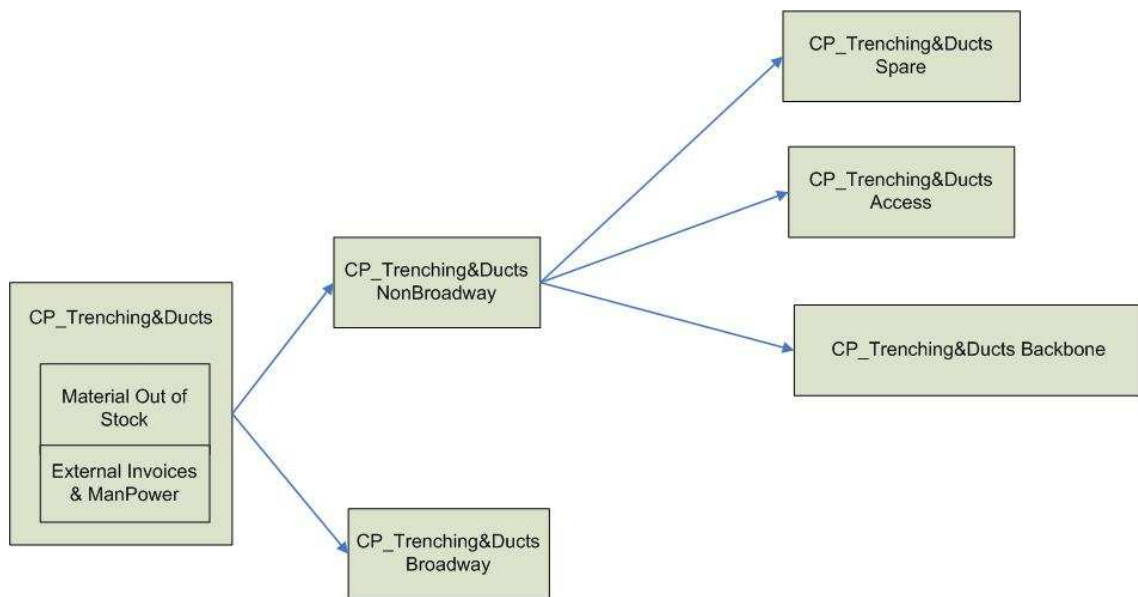

Finally, the costs of the entity Trenching&Ducts_access are fully allocated to NE_FibreAccess and the costs of the entity Trenching&Ducts_Backbone are fully allocated to the NE_FibreBackbone. The costs of the Trenching&Ducts_Spare are fully allocated to the NE_Trenching&Ducts_not allocated. The costs related to the Trenching&Ducts_SpecificBroadway go fully to the NE_forFutureServices.

11.3 Split of the fibre cable investment costs.

Cost sources:

Fibre cable (fibre material, blowing and splicing) investments are subject of separated assets. These are listed in the following table and are preliminary pooled according to their content into either “BroadwayFibreCable” specific pool, or in a FibreCable cost pool, or in an Access FibreCable cost pool.

Since the beginning of the Broadway project, all related fibre cable investments are booked in the AC1343. That is the reason why this asset is the only one that needs a preliminary treatment to neatly separate Broadway related investment. This split is merely based on the yearly investments in that asset due to the Broadway project. This

information is directly available in the financial systems and is further indexed to actualize the cumulated investments.

Split of the pool CP_FibreCable:

This cost pool gathers all the CAPEX and OPEX costs (including support costs) related to all “non-broadway” fibre cables; it is further split into Access Fibre and Backbone Fibre pools. The driver for this split is the number of Km Fibre totalized for access or for backbone. The value of this driver is derived from the ITR inventory database where all fibre bundles are documented as well as their length.

12 Top Down Backbone Model

12.1 Introduction

The aim of the PPP Fully Allocated Cost (FAC) model is to allocate all the known investment costs as well as the operational costs, to the various services which are offered by Belgacom to its customers (both internal and external), by defining a causal relationship between the general ledger and the end user services (Figure 12-1). Since the basic network infrastructure is used by a variety of services, which is in particular true for the backbone network, a number of allocation keys is determined to distribute its cost between the services. These allocation keys are based on the usage of the network infrastructure by each service, which can be determined by using the information available in the technical databases.

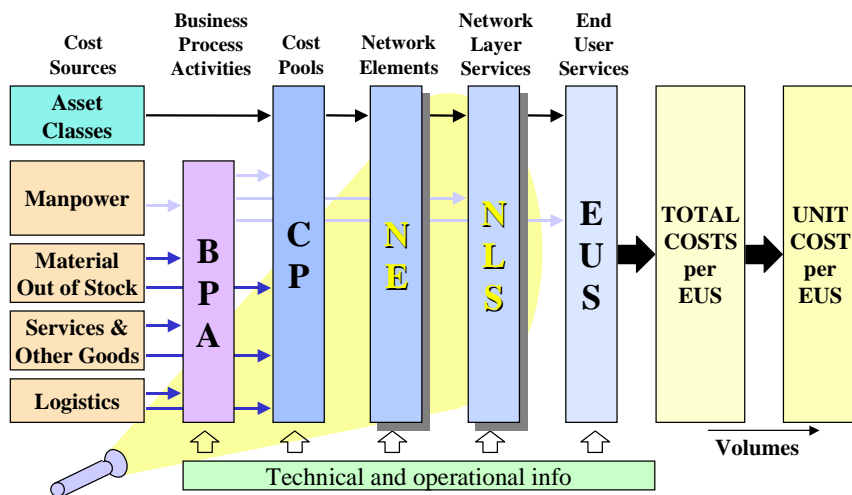

Figure 12-1 The objective of the FAC-Model

In this chapter we will highlight how the allocation keys between the Network Elements (NE) and the Network Layer Services (NLS) for the backbone network are determined.

12.2 Basic components of the model

12.2.1 Network elements

12.2.1.1 Type of network elements and location in the network

The Network Elements (NE) can be considered to be the building blocks of which the network infrastructure is composed. They represent the different types of cables in different parts of the network (Figure 12-2), and the different types of equipment to be found in the network nodes (Figure 12-3). These network elements can be related directly to the data entities in the technical infrastructure databases, so that the degree by which they are used by the various services can be determined.

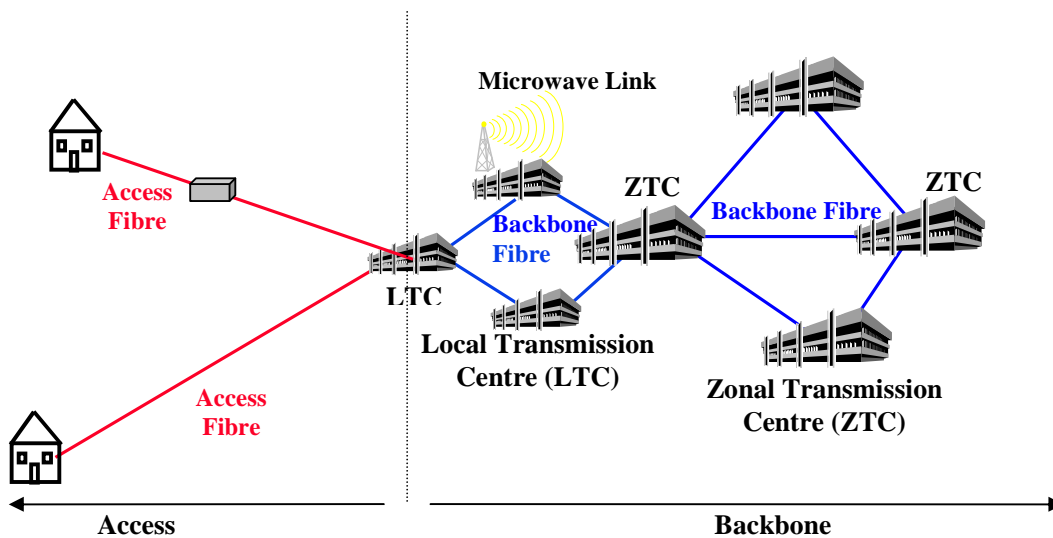

Figure 12-2 Network elements: types of cables

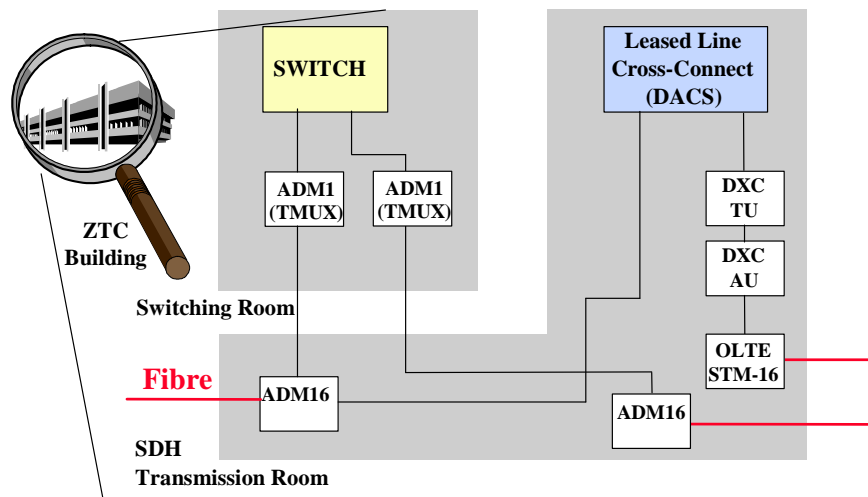

Figure 12-3 Network elements: an illustrative example of equipments in a network node

For what concerns the backbone network we are dealing with the following network elements:

- Backbone and access fibre cable. The cable infrastructure going from the customer to the Local Transmission Centre (LTC), Optical Nodes or Local Distribution Centre (LDC) included, is considered as being the access part of the network. The backbone part is that part of the cable infrastructure providing transmission capacity between the LTC's and Zonal Transmission Centres (ZTC).
Also coax cables and symmetric copper pair cables are taken into consideration. The access fibre cables are treated by the backbone model since they are documented in the technical database ITR. The same applies for the 2Mbit/s systems on copper (HDSL).
- PDH (Optical) Line Termination Equipment ([O]LTE): LTE140M (140Mbit/s on coax), OLTE140M (140Mbit/s on fibre), OLTE34M (34Mbit/s on fibre).
- PDH Multiplexers (various interfaces): MUX34M40, MUX2M8, MUX8M34, MUX2M34.
- LTE2M (2Mbit/s on copper, HDSL), DNT-2M and Syrar (multiplexing equipments with various input interfaces and a 2Mbit/s output signal).
- SMUX: multiplex system for leased lines.
- DACS: cross-connect system for leased lines.
- SDH Optical Line Termination Equipment: OLTE-STM16 (STM16 or 2.5Gbit/s on fibre), OLTE-STM4 (STM4 or 622Mbit/s on fibre).
- PDH & SDH LTE also exists with microwave interfaces.
- SDH cross-connect systems: DXC-AU (cross-connect on VC4 or 140Mbit/s level), DXC-TU (cross-connect on VC12/VC3 or 2Mbit/s and 34Mbit/s level).
- SDH Add Drop Multiplexers (i.e. ADM) of various types: AU or TU, different matrix size determining the add-drop capabilities and different line system interfaces.
- DWDM equipment: Ericsson, Huawei and Nortel equipment like OMT (Optical Multiplexer Terminal), OLA (Optical Light Amplifier) or OADM (Optical Add Drop Multiplexer).
- Optical Line Termination Equipment (OLTE) used to enable the transmission/reception of the Ethernet, Fast Ethernet, Gigabit Ethernet, Fibre Channel protocols (OLE-Ethernet, OLE-Fast Ethernet...) or to provide ATM interfaces (OLE-OC).

12.2.1.2 Network topology and equipment functionalities

The network topology and equipments functionalities are not documented as such in the transmission infrastructure database. However, for modelling purposes, it may be interesting to categorise the network in layers and to classify the equipments according to their functionalities. In this way, dedicated allocation approaches can be set up for distinct network entities.

Actually, the network is made of a core express layer, a core normal layer and a regional layer. These layers are constituted of rings objects (Figure 12-4):

- the core express rings connect the main ZTC of the network, with an under laying DWDM network.
- the regional rings connect several LTCs to one ZTC. One ZTC node can bind more regional rings (clover structure).
- the core normal rings connect several ZTCs to two ZTCs belonging to the core express layer.

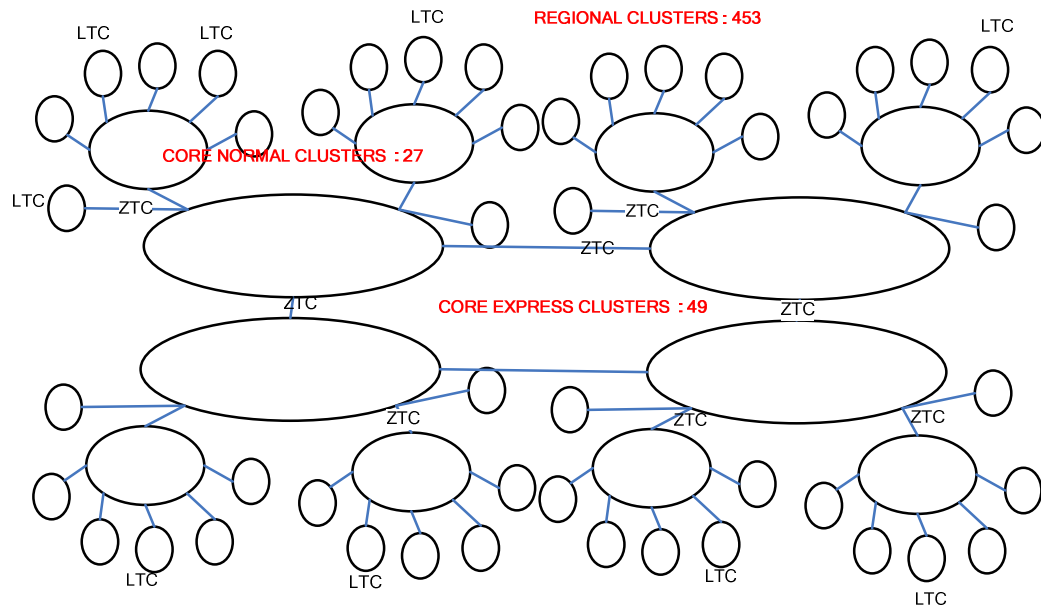

Figure 12-4 Backbone network layers

Equipments used to build ring structures are ADM (Add-Drop Multiplexers). These ADM are classified among NE_EXPRESS_RINGS, NE_NORMAL_CORE_RINGS, NE_REGIONAL_RINGS.

Other ADM are used to perform

- grooming functionalities used to aggregate various input signals into limited outputs in order to reduce the required tributary interfaces on ring ADM.
- cross-connection functionalities: ADM equipments assembled together to emulate a Digital Cross Connect. This solution gives higher cross-connection capabilities than a single ADM.
- terminal multiplexer functionalities used to aggregate PDH signal (E0,E1,E4) into an STM-1.

12.2.2 Network layer services

A Network Layer Service (NLS) is a service offered by one layer of the network contributing to either a network layer service in another layer of the network, or to an End User Service (EUS). The backbone layer will deliver the basic network layer services to the switching layer and the data layer. The trunk lines between switches for example are realised through 2Mbit/s transmission systems in the backbone network. Hence we can say that the network layer services “Zonal 2Mbit/s Transmission System for Switching” and “Interzonal 2Mbit/s Transmission System for Switching” in the backbone layer are services offered to the switching layer, which contribute to the cost of the switching trunk network (Figure 12-5).

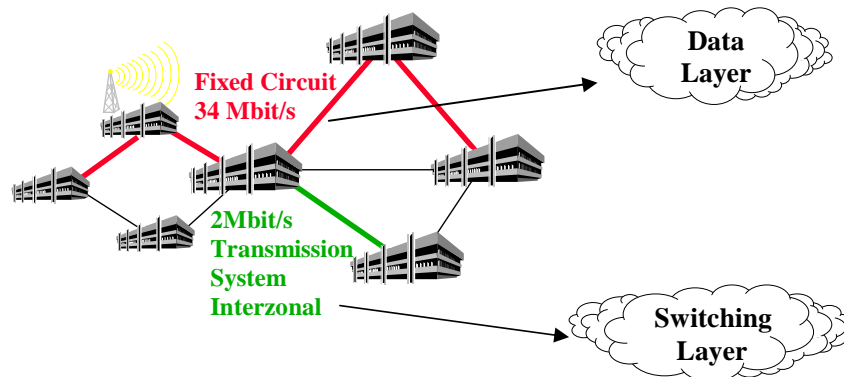

Figure 12-5 Network Layer Services: an illustrative example of NLS (fixed circuit access to data; 2Mbit/s trunk for switching).

We can distinguish backbone network layer services such as, for example:

- Zonal 2Mbit/s Transmission Systems for switching; Interzonal 2Mbit/s Transmission Systems for switching between either adjacent zones or non-adjacent zones; Local junction 2Mbit/s Transmission Systems between Basic Switching Units (BU) and Remote Switching Units (RSU). These NLS concentrate transmission costs related to the switching 2Mbit/s backbone trunks. They are further processed and allocated in the switching layer of the model.
- Fixed Circuits of various rates: analogue, sub-2Mbit/s ($n \times 64 \text{Kbit/s}$; $1 \leq n \leq 31$), 2Mbit/s, more than 2Mbit/s. A fixed circuit is that part of a leased line using backbone infrastructure. It is called a fixed circuit because it remains unchanged, whether there is traffic on it or not, unlike the switched circuits in the switching layer which are set up on a call by call basis.
- Data trunks of various bit rates (from 2Mbit/s to 2,5Gbit/s Transmission Systems). These data trunks are regrouped and handled under several Network Layer Services. They concentrate all the backbone transmission costs related to the data network. These NLS are further processed and allocated to data services in the data layer of the model.

The cost of a Network Layer Service is determined by the network elements (cables, equipment) it uses. It is the objective of this chapter to show how the cost of the network elements can be allocated to the various backbone network layer services.

12.3 Transmission Cost Allocation

12.3.1 Network entities definition

Prior to presentation of the cost allocation methods and used drivers, the hereunder paragraphs give the details of the definition of network entities used into the transmission world.

12.3.1.1 Line systems

The basic transport capacity between nodes of the backbone network is provided by the line systems. A line system is a high-capacity transmission system to transport an aggregation of connections between transmission centres of the network. The line systems are the “high ways” in the network. A line system consists of a transmission medium (mainly fibre in the backbone network, although also some microwave links are used; fibre, copper and microwave links in the access network) to carry the transmission signal, and the equipment at both sides terminating the signal, the Line Termination Equipment (LTE).

The SDH¹ systems range from STM¹⁻¹ (140Mbit/s), over STM-4 (622 Mbit/s), STM-16 (2.5 Gbit/s) up to STM-64 (10 Gbit/s).

¹ SDH = Synchronous Digital Hierarchy

The older PDH² systems (which are gradually removed from the network, only remain in the access network) range from 2 Mbit/s, 34Mbit/s to 140 Mbit/s systems.

12.3.1.2 Transmission systems and multiplexing hierarchy

To exploit the high bandwidth of transmission media such as fibres, a number of low capacity signals (called “tributary signals”) are combined into a high capacity signal (called “aggregate signal”) which is transmitted across the line system. This aggregation of signals is called multiplexing. It implies that the line systems are shared by different transmission systems, and that their cost will have to be distributed accordingly. The SDH STM16 line systems for example can carry 16 VC4s (16 times 155Mbit/s). We say that it has a capacity of 16 VC4 time slots. Through the routing information in the technical database we can determine how much capacity is used (i.e. how many time slots) on each line system by each type of transmission system (Figure 12-6).

The concept of multiplexing can be applied in several steps, i.e. the higher order transmission systems themselves can also be composed of lower order transmission systems. The capacities of the different transmission systems are standardised in what is called a multiplex hierarchy.

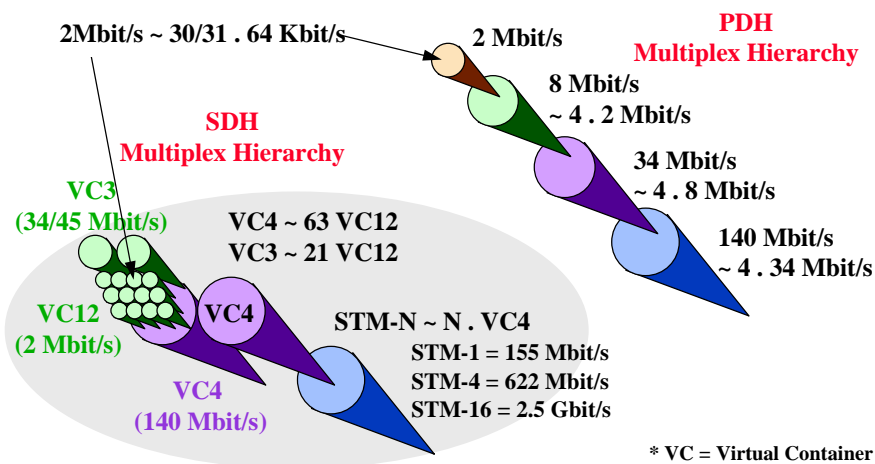

Figure 12-6 SDH hierarchy

12.3.1.3 WDM layer

DWDM (Dense Wavelength Division Multiplexing) is used to increase the usable bandwidth of fibre optic cables. It is a multiplexing technique combining several optical signals onto one fiber.

While SDH technology allows transmission speeds on fibre of 155Mbit/s (STM-1) up to 10Gbit/s (STM-64), a DWDM 32-wavelength system installed on one fibre, each carrying one SDH STM-16, has a total capacity of 80Gbit/s.

¹ STM = Standard Transport Module

² PDH = Plesiochronous Digital Hierarchy

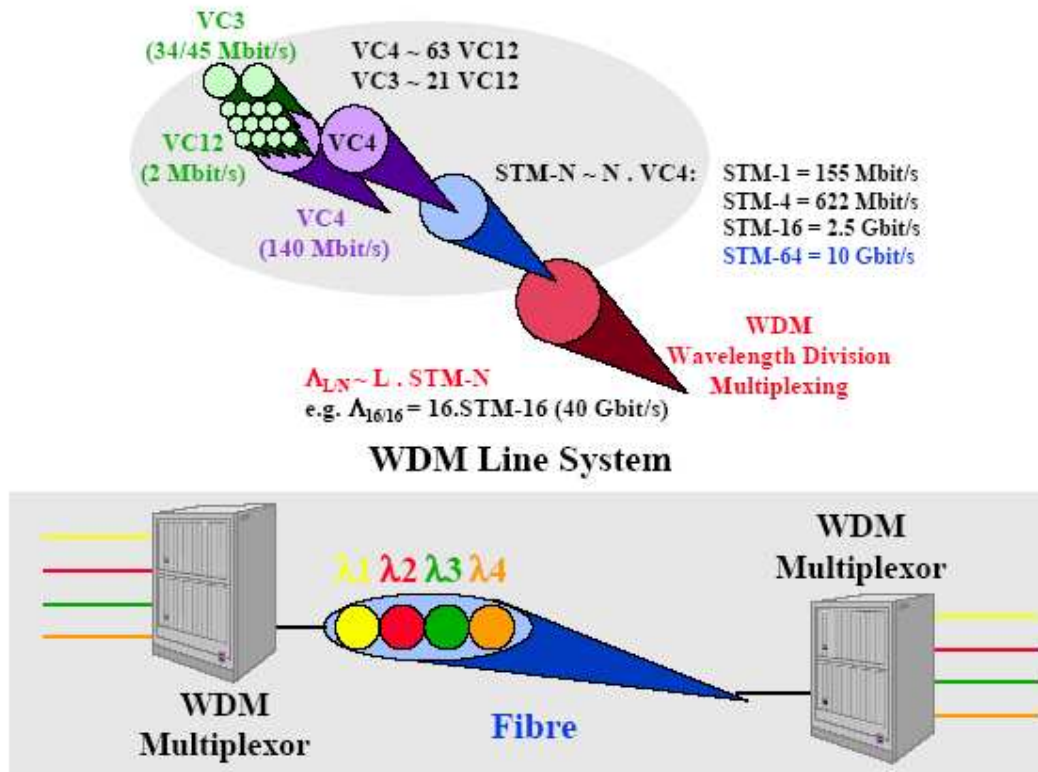

Figure 12-7 the WDM layer

The DWDM wavelengths (also called colors or lambdas) are multiplexed on one single fibre using Optical Multiplexer Terminals (OMT).

If the distance between the two OMT is too large (typically, more than 80-100 km), an Optical Line Amplifier (OLA) is used to compensate the fibre attenuation.

If only a set of wavelengths needs to be extracted/added from/to the DWDM signal, an Optical Add Drop Multiplexers (OADM) will be used.

While DWDM is mainly used in the backbone network, it can also be deployed in the access network for large customers with high bandwidth needs. Nevertheless, the access network will mainly make use of cheaper equipments offering limited wavelengths (typically 4 or 8). In this case, we talk about CWDM (Coarse WDM).

Another means of increasing the bandwidth on a single fibre at low cost is to use WDM cards called Combiner/Splitter. This technique allows transmitting two signals on the same fibre by using both of the two basis transmission windows of the optical spectrum, the 1300nm and 1550nm.

The WDM layer can be seen as an intermediate layer between the fibre assets and the line systems level. The WDM layer receives the cables cost and indirectly acts as the transmission medium for the line systems it transports.

12.3.1.4 Ring objects

Add Drop Multiplexers are often assembled in a ring structure allowing the protection of the traffic. Protection mechanisms exist which enable to switch from a working path to a protection path in a few milliseconds.

The Sub Network Connection Protection (SNCP) or the Multiple Section Shared Protection (MS-SP or MSP) protection mechanism both require working paths associated to dedicated bandwidth and protection paths.

12.3.2 Allocation methods and used drivers

The cost allocation process is based on the treatment of the routing information directly coming from the transmission inventory database. In this database, each entity (fibre cable, line system, transmission system and equipment) is assigned to unique reference number. The routing tables provide the detail of the connectivity of each individual entities and interdependencies between them. This permits to ensure that every fibre cable, equipment or transmission system will be related and attributed to the various network layer services using it.

Also, the usage of the ADMs forming the SDH rings is determined from the same inventory.

The other ADM with different functionalities and the DXC needed to interconnect the different ring clusters also require a specific allocation process. These equipments are modular, which means that the connected capacities can strongly evolve in time (additional line or tributary interfaces).

12.3.2.1 Modular equipments

The direct attributable costs of a modular equipment are attributed to the various NLS connected to it. The driver used is the bandwidth of the services.

12.3.2.2 Meshed network

The driver used to allocate the costs of the equipments that are part of the meshed network is the consumed bandwidth.

These equipments can be defined in contrast to the previously paragraphs being the non-shared infrastructure equipments and the non-modular equipments.

Each service linked to an equipment is associated to a "signal stack" which describes the different transmission systems used to carry the signal across the network. This information is directly provided through the processing of the routing information.

The allocation of the equipment costs can be determined by processing the signal stack attached to the routing of the service.

12.3.2.3 Fibre infrastructure and WDM network

The routing database provides all the necessary information concerning the fibre cable bundles: cable length, cable size, interdependencies with the transmission systems using them.

In the first place, the routing is used to distribute the total backbone fibre capacity among the two modelled entities that make use of it, the rings structures and the meshed network. The used driver is the consumed fibre length.

Then, the fibre infrastructure allocation will be made depending whether the cable bundles are making use of the under laying DWDM network, CWDM, combiner/splitter equipment or not.

12.4 Conclusion: The Backbone Cost Structure

The cost structure of each of the backbone network layer services serves as an input to determine the cost of other network layer services supported by the backbone, or to determine directly the cost of end user services. As we already mentioned, the cost of the trunks for switching will be treated directly by the switching model and the cost of the data trunks will be handled by the data model. The cost of fixed circuits will contribute directly to the leased line services. However, some of the fixed circuits are used for networks of Belgacom itself, such as the data networks (X.25, ATM). The cost associated with these fixed circuits, a fraction of the total cost of that type of fixed circuits determined on a volume basis, therefore contributes to the cost of data trunk networks, and will be further treated by the data network model (Figure 12-8).

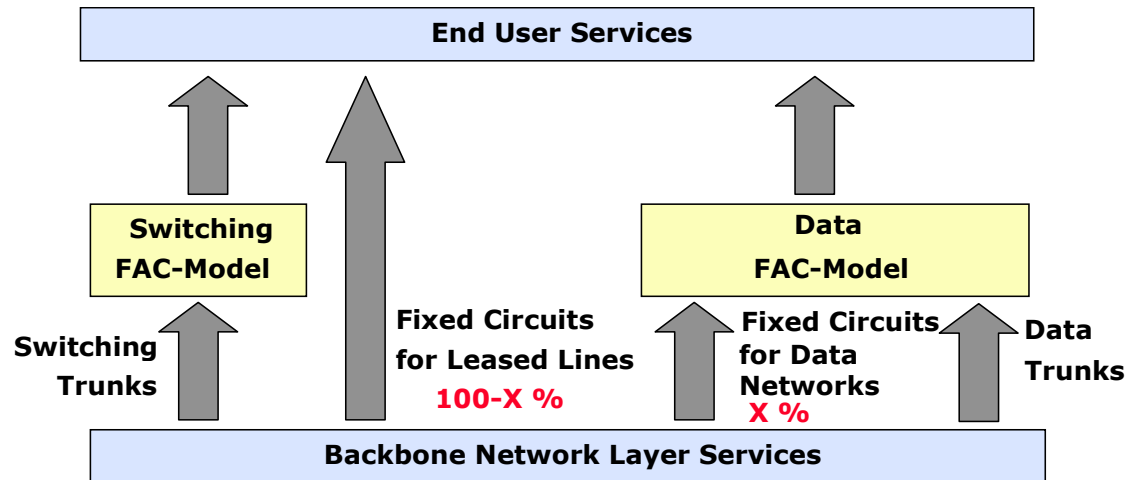

Figure 12-8 Further allocation of backbone network layer services

13 Top Down Switch Model

13.1 *Basic components of the model*

13.1.1 Cost Pools

Cost Pools consolidate all kinds of costs (depreciation of assets, labour, material out of stock, services & other goods, support costs) in technical groups offering different functions.

In the switch model, there are five families of Cost Pools:

- 1) Basic Switch Platform
- 2) IN Platform
- 3) Control & Supervision of Switch functions
- 4) Charging
- 5) Platforms/equipment for specific services

13.1.1.1 *Basic Switch Platform*

This is the main family of switch cost pools. It contains the whole infrastructure to provide basic PSTN and ISDN calls.

The switches spread throughout the network can be categorised into three types of switch nodes. Even if they share lots of common parts resulting in economy of scales, they each perform some specific tasks. We have the basic unit (BU), the remote unit (RU) and the transit switch (nowadays called CAE). We will take a closer look at the network and these switches in order to understand how they perform their work. In the year 2000, the last analogue switches were taken out of service. Hence, as from the 2001 model, only digital switches are taken into account.

The switch network architecture is built through interconnections between these three types of nodes. In the year 2000, the network architecture has been simplified. Belgacom now operates in a 2 layer network. The local exchanges (RU and BU) are the lower level, the transits (CAE) make up the higher level.

In Figure 13-1 the structure of the CAE network is shown. All prefix zones are grouped in 8 areas. Each area contains 2 CAE to handle all the transit traffic.

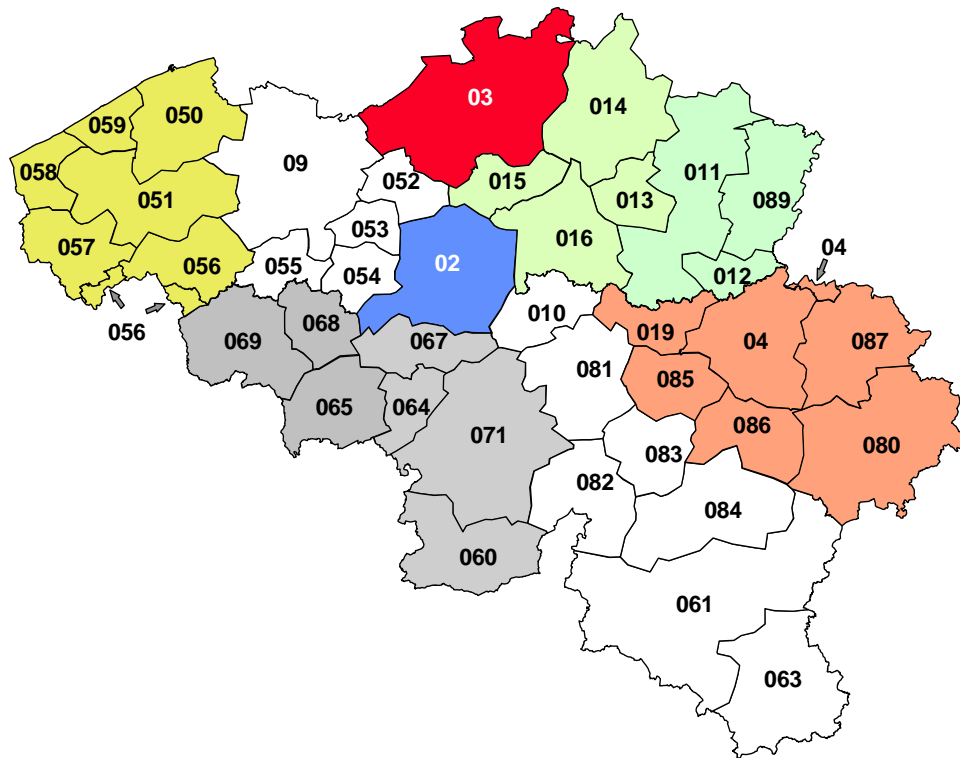

Figure 13-1 CAE switch architecture

13.1.1.1.1 Basic Unit

A Basic Unit (BU) is dimensioned to manage the connections of 10.000 customers or more. The hardware mainly consists of a switch matrix, the customer line cards and the 2Mbit/s trunk cards (Figure 13-2).

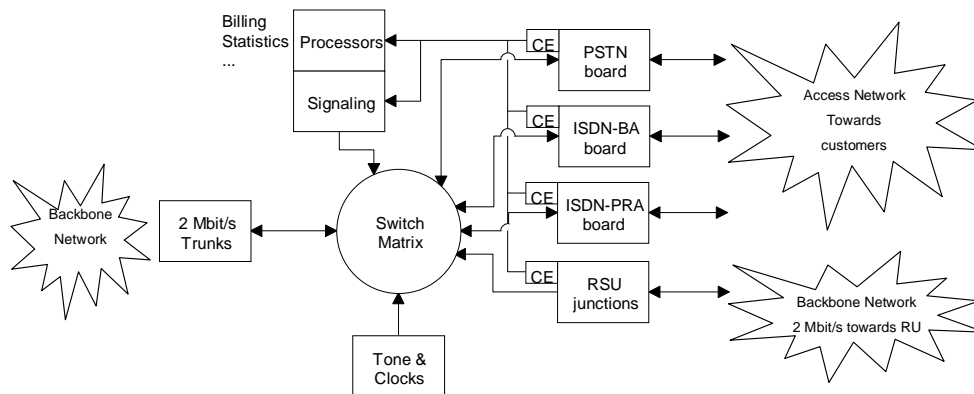

Figure 13-2 Basic Unit

The switch matrix sets up the connections when customers call, which is the main function of the switch. The size of the matrix depends on the number of connected access lines and trunks (to other BU or to underlying RU). The larger the capacity, the larger the matrix. The connection between the matrix and the customer copper pairs is performed by the line cards. There are several types of line cards, but the main ones are for PSTN, ISDN-BA or ISDN-PRA lines. The matrix and the line cards allow customers, connected to the same switch, to call each other,

but they can not call customers linked to another switch. For this to be possible, the BU's have to be connected to each other through 2Mbit/s trunk cards. 2Mbit/s trunk cards are sensitive to the traffic which is not terminated locally, i.e. the traffic between customers not connected to the same switch.

Beside these 3 elements, there are still others such as the processors generating the "Call Detailed Records" (CDR) for billing the customers, and the signalling modules through which the switches talk to each other.

Until 2002, the switch contracts foresaw in a price per equivalent line (one equivalent line equals a 64kbps channel). This changed however in 2003, when new switch contracts became applicable. These contracts are based on a "maintenance mode", which means that we no longer foresee to order any extra capacity. The switching network has reached saturation. The number of customers or the amount of traffic is expected to decline rather than to rise. The contracts specify a price per piece of equipment, or per performance (# working hours), in case replacement or other intervention is necessary.

In order to be able to still estimate the global value of the switches, studies have been performed to convert the price per part to a price per switch (fixed cost) and per line (variable part).

13.1.1.1.2 Remote Unit

The remote units (RU) share a lot of hardware with the basic units, in particular the line cards and the 2Mbit/s trunk cards (Figure 13-3). Compared to a BU, an RU is incomplete with respect to the matrix and the processors. It does not have a complete matrix¹ and all the processing for call handling is performed by the BU hosting the RU. Because of this incompleteness, an RU can not work as a stand alone unit. It needs the support of a BU, its host, to be able to perform its task. This link between an RU and BU is set up through the RU junctions. From a transmission perspective, a RU junction is a simple 2Mbit/s transporting proprietary protocols for remote control by the host. Every call going beyond the RU is switched and handled by the BU through the RU junctions.

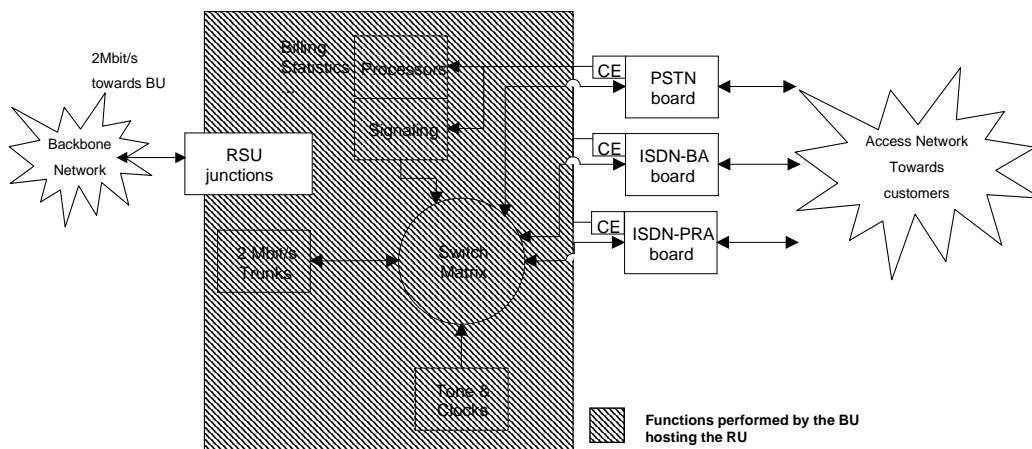

The more traffic on the customer side, the more 2Mbit/s are needed between the RU and the BU hosting the RU. Junctions between RU and BU are traffic sensitive.

Figure 13-3 Remote Unit

The RU's have been deployed for several reasons, the main one being economic. An RU requires less maintenance work. No software upgrades are needed since it is the software of its host, which controls the RU. A RU may also be deployed to shorten the copper distance in the access network. In this case they are called LDC (Local Distribution Centre) and are located in the access network.

¹ An RU is able to switch local calls, i.e. between customers connected directly to the RU, but under very strict conditions.

13.1.1.1.3 Trunk Unit

It is not possible to connect all basic units to each other. This would not be cost-efficient, since too many 2Mbit/s trunk cards carrying traffic between a pair of BU would have very low usage ratios. To overcome this problem, a hierarchy has been introduced in the network. All BUs are interconnected through Trunk Units, nowadays called CAE (Covering Area Exchanges). The main difference with a BU is that Trunk Units do not have any customer line cards. Otherwise, they are completely equipped.

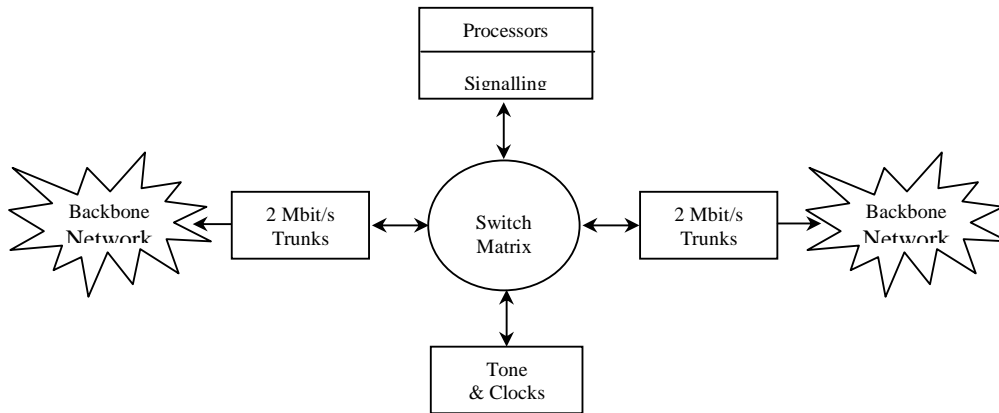

Figure 13-4 TrunkUnit

The table below clarifies the differences between RU, BU and CAE at the level of the customer line cards, the matrix and the 2Mbit/s trunk cards. The three types of switches do not include all these costs.

	2 Mbit/s Trunk cards	Switch Matrix	Line Cards
Trunk Site	yes	yes	No
Basic Unit Site	yes	yes	Yes
Remote Site	yes (only to the host BU)	no	Yes

The analytical accounts are not detailed enough to deliver all that information. Despite the fact that the cost drivers defined above are based on elementary engineering rules, they can not be distinguished as such from the financial records (the asset classes), since our historical switch contracts were completely different in their pricing approach (based on equivalent lines, rather than on separate parts).

We proceeded in the following way. The number of equivalent lines¹ in service at respectively the trunk and the customer side of each switch unit, taking into account the technology (Alcatel or Siemens), are extracted from the switch database. They allow us to split the total cost in 3 parts: RU, BU and CAE (Figure 13-5).

¹ An equivalent line (EL) for a PSTN line is 1. An ISDN-BA line is 2 EL worth, an ISDN-PRA weights 30 and a trunk 30. These numbers are used in the switch contracts with the vendors.

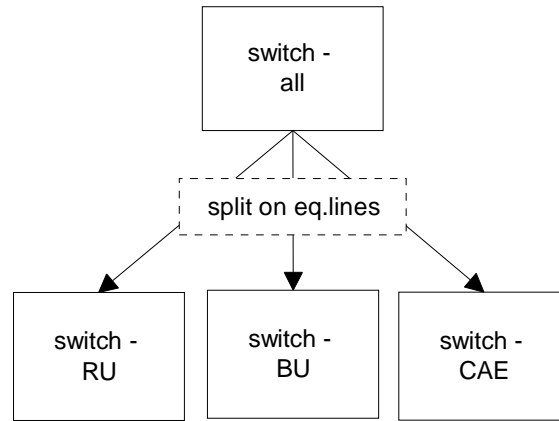

Figure 13-5 Split of switching costs in 3 switch types

13.1.1.2 IN Platform

Some services request the deployment of additional features on top of the basic switch network. Typically these services request user friendly guidance for the customer, fast access to centralised service databases and centralised management of service data. Currently these services are implemented on the intelligent network platform. The Intelligent Network (IN) is an architectural concept. The functions supporting the global network services are concentrated into intelligent nodes. These nodes contain the software, the databases and the logic needed to manipulate the necessary information. As such IN allows an independent service creation and a control independent from the underlying network, i.e. the basic switch platform.

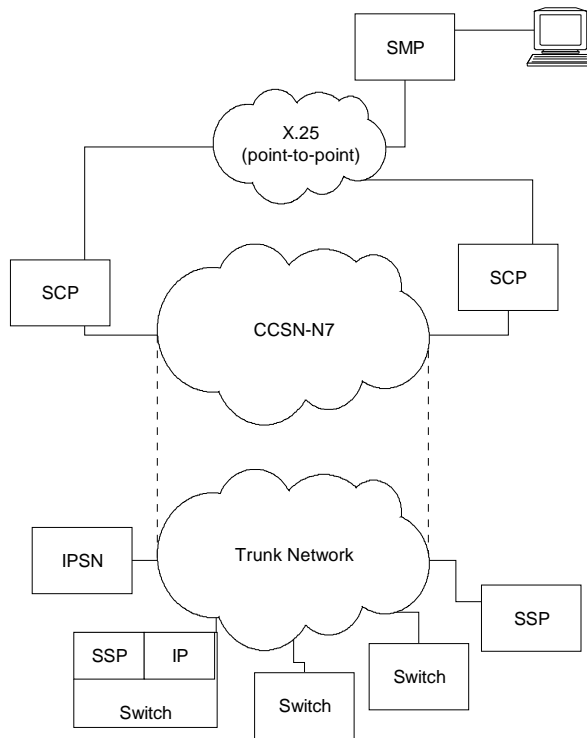

Figure 13-6 IN network

The main IN components are the SSP (service switching point), the SCP (service control point), and the SMP (service management point). Several entities of each type exist. A detailed description of these building blocks can be found in the paragraph of the IN cost allocation.

At this stage, six explicit cost drivers are identified as cost pools: CP_Voice Mail, CP_IN Hardware (which contains both SCP and SMP), CP_IN software (i.e. general system software to run the platforms), CP-IN Applicative Software (for the management of specific services) and two specific components: the IN CNA/SRP platform and the IN VMS platform. The IN platform is also consuming resources of the basic switch trunk network (the SSP-functionality in the CAE and LEX).

13.1.1.3 Control and Supervision

Control and supervision is about the remote or local management of the switch infrastructure. This infrastructure contains a lot of different types of equipment which may, or may not, be dedicated to independent services. In Figure 13-7 the mapping of the assets related to control and supervision, and the cost pools, is shown.

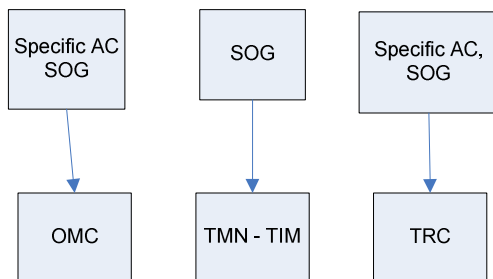

Figure 13-7 Specific equipment

CP-OMC

Operation and Maintenance Centres supervise, configure and control the switch units. A specific network, called Megapac, interconnects the switches and the OMC. Each switch is connected to an OMC, where several servers (HP and Motorola machines) control all parameters of the switched services. It is via the OMC and the Megapac network that commands can be sent to the switches, and reports from the switches are sent via the OMC to the personnel in charge of monitoring the switches and their traffic.

e.g.: Some equipment can simulate calls to observe the quality of service.

CP-TMN-TIM

TIM is mainly assigned to the surveillance of all the Belgacom switches and to the monitoring of Belgacom's SSN7 network. For the supervision of the switches, TIM has handled mainly three categories of alarms:

- software alarms concerning the switching activities
- hardware alarms from the switching equipment
- hardware alarms related to the environment of the switches

13.1.1.4 Charging

Charging is about collecting and processing call information to charge the customer for the consumed services. Specific software and hardware perform this task.

CP-TRC

The termination registration centres collect all the information from the basic units to populate the customer invoice database. The parameters of the calls are processed to generate a charging ticket.

13.1.1.5 Specific Equipment

Several units/devices are dedicated to specific services: the OPS Platform and PABX.

13.1.2 Network Elements

The Network Elements (NE) are the building blocks of the switch network infrastructure. The NE are defined in such a way that they have an unique cost allocation rule. A further split of cost pools into NE is needed for the basic switch and IN platforms. For the other cost pools, there is a one-to-one relation with the network elements.

13.1.2.1 Basic Switch Platform

As explained in a previous section, our switch contracts used to be based on a flat rate per subscriber line. Consequently the line price covered the matrix dimensioning. That element is more traffic sensitive, while customer lines are more access sensitive. Thus it is necessary to identify in the flat rate, which percentage of the price is traffic sensitive and which part is not. This is illustrated in the table below where the cost pools for line cards are split into an access sensitive part, which is called switch – access, and a traffic sensitive part, called (local or CAE) switch – traffic peak. The word “peak” indicates that the switch is dimensioned on peak traffic, rather than on the average traffic, or on the volume over 24 hours.

Elements which are not dimensioned on peak traffic, but where the split is more correct when considered over the total traffic volume, are grouped in a separate CP and NE. This covers some computer applications and certain operations.

The current percentages access – traffic peak are based on expert quotes from our suppliers. Each component of the switch was analysed, and attributed totally or partially to the access or traffic part. When taking the number of components and their price in consideration, an overall percentage per switch type can be calculated.

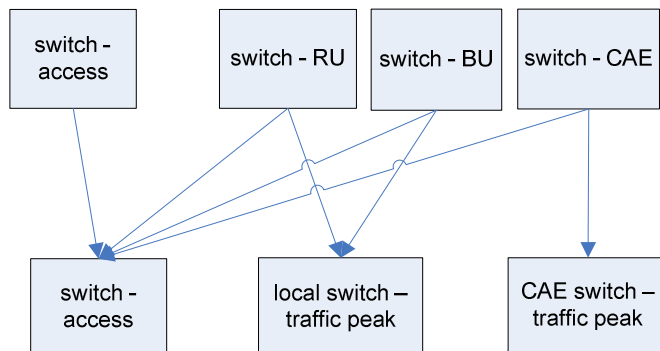

Figure 13-8 switch types and their allocations

13.1.2.2 IN platform

There is a one-to-one mapping between the cost pools and the network elements voice mail and IN VMS platform.

The cost of the IN CNA/SRP platform is allocated to the CP_switch – traffic as it is serving all the traffic types by providing standard messages (e.g. when the called party cannot be reached).

For IN Software, the cost of the generic software is added to the cost of the application software in order to map it to services at a later point.

The IN hardware cost pool (containing all hardware apart from voice mail, CNA/SRP and VMS platforms) is split onto the different components of the IN Architecture listed hereafter.

NE_SCP platform – high end;
NE_SCP platform – low end;

NE_SMP platform – high end;
 NE_SMP platform – low end;
 NE_IN – CPU
 NE_IN – RAM
 NE_IN – disk

SCE = Service Creation Environment
SMP = Service Management Point
SCP = Service Control Point
SSP = Service Switching Point
IP / SN = Intelligent Peripheral / Service Node

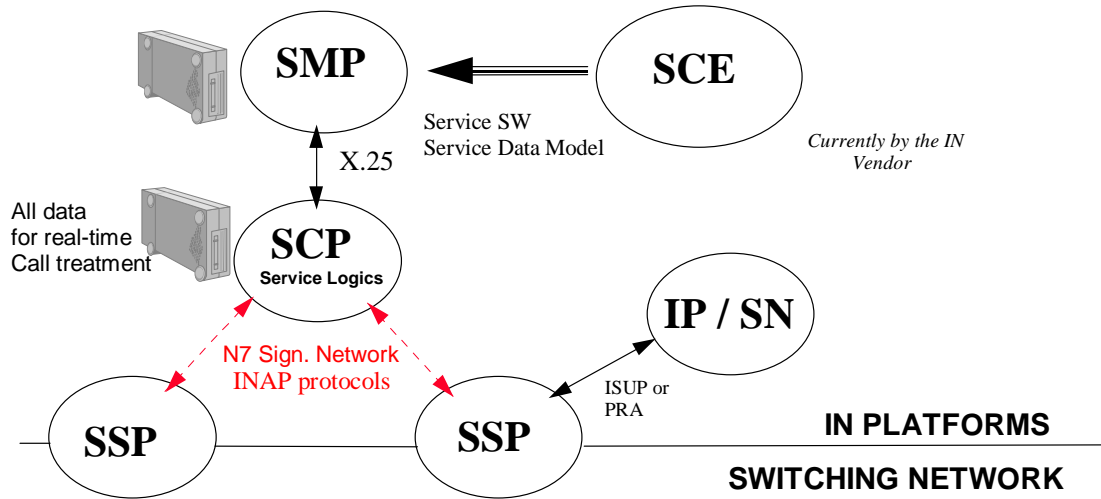

Figure 13-9 IN platform

The IN platform uses a technology based essentially on computers. It implies that capacity prices keep dropping. That is the reason why the IN assets are depreciated in 4 years only. The allocation keys for the network elements have been based on the replacement costs of the IN platform. This was achieved by asking the technical people of Belgacom IN platform to evaluate the cost, using today prices, for the hardware and software components of the IN network. The ratios of the IN-network element costs to the replacement cost of the IN-platform, are used to split the amounts of the cost pools.

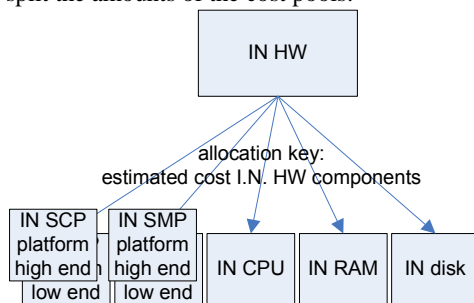

Figure 13-10 IN Hardware Network Elements

13.1.2.3 Control and Supervision

There is a one-to-one mapping between the cost pools and the network elements.

13.1.2.4 Charging

There is a one-to-one mapping between the cost pools and the network elements.

13.1.2.5 Specific equipment

There is a one-to-one mapping between the cost pools and the network elements.

13.2 Cost Allocation

In this section, the cost allocation rules are defined. They are mainly based on the cost drivers defined in the previous part of the document.

13.2.1 Cost Allocation for the Basic Switch Platform

13.2.1.1 Customer access sensitive

In the basic switch platform, a group of Network Layer Services (NLS) is customer access sensitive: the ISDN and PSTN accesses.

These NLS cover the cost of the access lines to the switches, which is mainly the cost of the access card plugged into the switch.

Eventually these NLS are combined with the NLS defined in the access model, such as the copper pair for example to reach the customer's home. The cost represented by these NLS covers the physical connections between the customers and our switches. Refer to the access model to get more details. The combination of these NLS results in the cost allocated to the End User Services (EUS) which are sold as the service subscription fees.

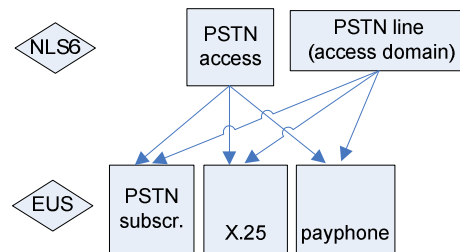

Figure 13-11 NLS – PSTN Access

Figure 13-11 shows that some PSTN access lines are not only used to connect our customers but also to support other services: payphones and X.25 indirect accesses.

13.2.1.2 Traffic sensitive

We proceeded in a step by step approach. Note that each step is kept independent from the previous ones to avoid dead-ends.

The objective is the reconciliation of the backbone NLS with those of the switch model. On the one hand, we have the transmission capacity of the backbone model carrying the switch trunks. On the other hand, we have the trunks connecting all the switches to each other and carrying a mixture of switched traffic. To achieve this reconciliation, a common ground must be found, which will be based on routing factors.

Besides the interconnection traffic, there are still other NLS to cover the fixed cost of the interconnection services. The 2Mbit/s trunks interconnecting Belgacom and the OLOs are mapped onto the NLS_POI (Point of Interconnection). We make a distinction between POI OIT (OLO Interconnect Traffic) and POI BIT (Belgacom Interconnect Traffic). A second distinction is made between LAP (local access points, connected to CAE/AGE switches) and AAP (area access points, connected to LEX).

13.2.1.2.1 ROUTING FACTORS

The routing factors indicate to what extent the different traffic types consume the resources of the network. They are the cost drivers to allocate the backbone and switch resources. The routing factors are multiplied by the “injected” traffic minutes, to become the “routed” traffic minutes. It is in fact this number which indicates the load of a traffic type on a specific resource. The resources to be allocated are either switch parts (e.g. the processors in the local switch) or transmission bundles that are servicing switched traffic (e.g. zonal trunks interconnecting two switches).

13.2.1.2.2 TRAFFIC END USER SERVICES

Instead of a one-to-one relationship between the NLS and the EUS, there is a one-to-many relationship for certain traffic types (see example hereunder). This is due to the definition of the NLS, which group traffic types sharing the same characteristics with respect to their routing. For example, no distinction is made between intra area interconnection traffic from fixed OLOs to Belgacom, since they are routed the same way and they consume the same amount of resources. This implies that, in terms of transmission and switch capacities, they are equivalent.

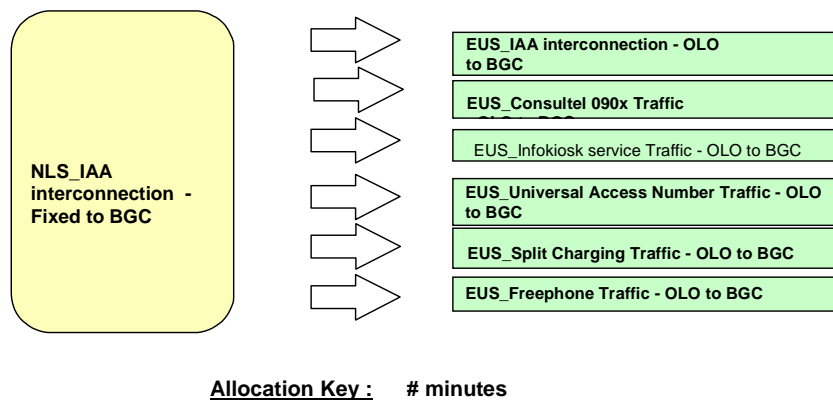

Figure 13-12 split of one NLS traffic into several EUS traffic

The general principle to allocate the NLS is based on the relative volumes of the traffic types associated with the same NLS.

In some cases the allocation process is more complex. This is the case for the IN platform. For example, the NLS_AFS (advanced freephone services) are divided over the different traffic types by analysing the number of calls and the complexity of the IN intervention per call type (traffic towards an OLO or traffic translated to a Belgacom geographical number).

13.2.2 Cost Allocation for the IN Platform

Only the costs of the platform running the IN services are tackled here. The costs linked to the traffic generated by the IN services have been addressed in the cost allocation of the basic switch platform (13.2.1.2). The cost allocation of the voice mail platform (ending in the EUS voice mail) and the IN VMS platform (absorbed in the EUS I.N. capacity for new services) is also separated from the elements below and needs no further explanation.

The key issue is the identification of the cost drivers. A prerequisite is the understanding of every IN network element. Therefore they have been explained in the next bullet points. Once identified, the relative service volumes are delivered by IN technical people for each cost driver.

SCE = Service Creation Environment
SMP = Service Management Point
SCP = Service Control Point
SSP = Service Switching Point
IP / SN = Intelligent Peripheral / Service Node

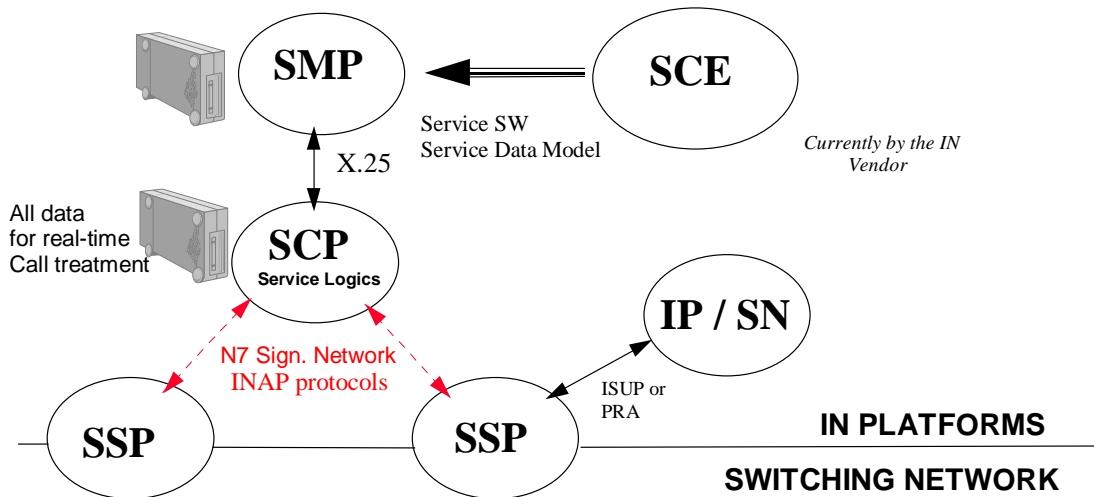

□ **Service Switching Points (SSP)**

A service user can, from anywhere in the network, invoke the service by dialling the service prefix. He gets access to IN services through a Service Switching Point (SSP). Not all our switches are equipped with an SSP function. For those not equipped the network can by means of normal call routing reach a SSP.

The SSP acts as the access point to the IN platforms. It is an additional function integrated in the basic unit enabling IN call identification and management. On receipt of an IN call, the SSP finds out what service is requested and collects all the necessary information to pass on to the Service Control Point (SCP). During the whole processing of the IN calls, the intelligent peripherals (IP) of the SSP act like the mouth and the ears of the SCP. Every time the SCP wants information, it interacts with the SSP. It is referred to as a transaction. Every SSP function is dimensioned to handle a maximum number of simultaneous transactions between the SCP and the SSP.

Information between SSP and SCP is carried through the Common Channel Signalling Network (CSSN) using the protocol Number 7 (SSN7). These channels are set up through the trunk network, which is itself built on the backbone network through 2Mbit/s links. So far, the cost for the signalling capacity is not taken into account.

The Intelligent Peripheral (IP) supports the interactivity with the service user. This is the mediator between the service logic in the SCP and the service user. In many cases services require verbal guidance to the service user (e.g. "Please enter your credit card number") on which the user has to react. The announcement modules perform announcements. The service user sends back information to the IP either as DTMF¹ signals or strings of text. This data is translated (DTMF decoding) by the DTMF modules and then forwarded to the SCP for processing. The sequence is fully controlled by the SCP but it is the SSP which acts.

□ **Service Control Points (SCP)**

The SCP contains all the intelligence of the services, i.e. the service logic. It works in real-time and is equipped with service databases. The service logic processes the various information received from the SSP and decides on

¹ DTMF = Dual Tone Modulation Frequency: The tone generate when pressing a key of a telephone.

the next steps according to the service scenario. The kind of requests coming from the service logic towards an SSP range from setting up a connection to monitoring events.

The SCP is composed of three basic parts:

- ♦ The hardware: a basic platform cost for each SCP, processors (CPU) and memory (RAM and disks). While the CPU processing time is driven by the number of simultaneous transactions, the memory requirements are driven by the memory space requested by the service databases for example. Each of these components has a cost which can be clearly identified. Secondly, the utilisation of the components by different services is estimated, based upon measurements on the platforms. These measurements are executed in peak traffic, executed by the I.N. personnel. Queries on the I.N. platforms reveal how much CPU, disk space etc... are occupied for the treatment of the different services.
- ♦ The generic IN software: the set of generic software components developed by the vendor and defining the capability of the IN platform. They are shared by all IN services running on the platform. As such the generic IN software is a fixed common & joint cost. We decided to allocate its cost according to the applicative software cost consumed by the services.
- ♦ The service application: it is the application specifically developed for the service. This application describes the service scenario managing the communication with the SSP. As such, the service application is a fixed direct cost and is directly mapped onto the right service. The allocation key for the application software is based on the total investment on software per service. The price info for the software is obtained through a yearly update of the list of purchase orders, obtained from the IN personnel. Only the cumulated purchases for software on new and still active platforms are taken into account. This is important since between 1998 and 2001, all services migrated to a new platform, any older software investments must be considered out of scope.

□ **Intelligent Peripherals and Service Nodes (IP/SN)**

To enhance our competitive position, Belgacom introduced a combined Intelligent Peripheral / Service Node (IP/SN). The IP/SN is the combination of an SCP and an IP function. Note that IP/SN is no longer integrated in a switch, it is an external device connected through 2Mbit/s links. The IP is used to offer enhanced user interactions such as speech recognition, announcements, voice mail, etc. The SN combines a service control function, a switching function, a service creation function, a service management function.

Following services are currently running on the IP/SN

- ♦ Remote Telecontrol of COMFORT services
- ♦ Home Control of Calling Line Identity Restriction
- ♦ Message Waiting Indication
- ♦ Some basic Interactive Voice Response Applications

□ **Service Management Point (SMP)**

An SMP contains all the functions necessary to support the technical and commercial management of the intelligent network and services. It includes remote maintenance, performance management and statistical analysis. The SMP has a direct interface to the management terminals (in some cases an interface with the national OMC - Operations Management Center) from which commands can be sent - such as "create a calling card subscriber" - and to which reports can be sent. The connection between the SMP and the SCP is performed by point-to-point X.25 connections. The cost drivers for the SMP are the same as the ones for the SCP.

□ **Service Creation Environments (SCE)**

The SCE is the software platform on which IN services are created, developed and deployed. The SCE can, in principle, allow service providers to create services independently from the IN vendors. The cost drivers for the SCE are the same as the ones for the SCP.

13.2.3 Cost allocation for Control & Supervision

The control and supervision equipment is used for various tasks ranging from provisioning and configuration of plug-ins (access line cards, trunk line cards) to traffic management. Getting information to understand the internal cost structure of these applications is practically impossible. Consequently, a lot of questions are left open. Let's take for example the OMC system. The system configures the customer line cards during line provisioning or

activation of the Comfort service. The cost driver for these tasks is typically the customer access line volume. But the OMC is also used to configure the routing of traffic. Which percentage of its costs should go to the customer lines and which percentage to the traffic? To answer these questions, we should have a very good insight in the software because these tools are first and foremost software intensive.

NE-OMC

These network elements costs are allocated according to the number of calls for the different types of traffic and are mapped onto the traffic NLS (Figure 13-13).

NE-TMN-TIM

This network element cost is allocated per minutes of traffic and is mapped on the traffic NLS (Figure 13-13).

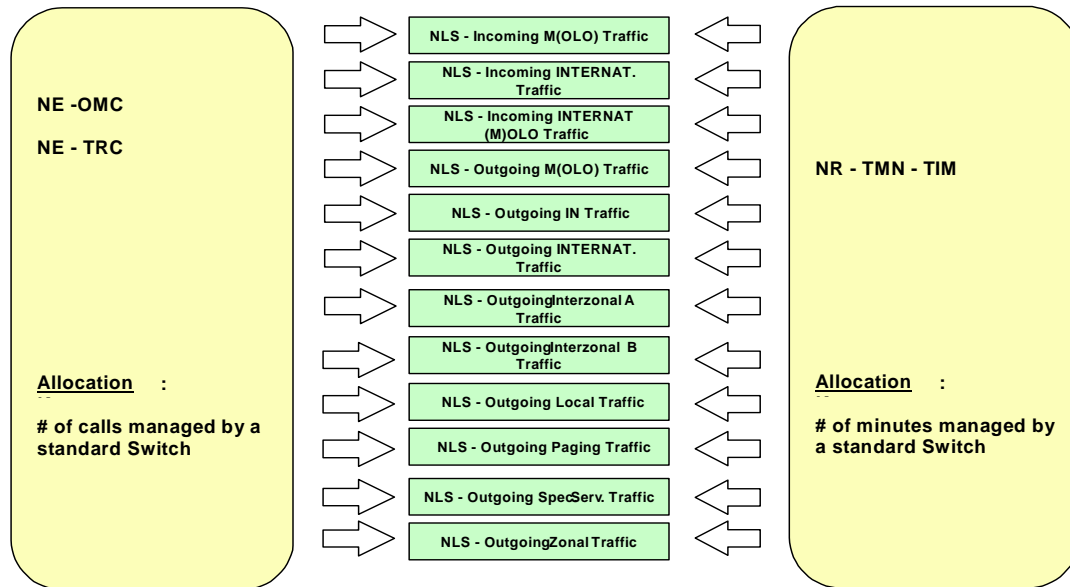

Figure 13-13 Allocation rules for Control & Supervision and Charging

13.2.4 Cost Allocation for Charging

This one is quite straightforward since every call generates a Call Detailed Record (CDR). The cost driver is thus the number of calls. Note that interconnection implies the generation of special records. As it is not really possible to get insight in the software to split the software cost, they are handled as normal CDR.

13.2.5 Cost Allocation for Specific Services

There is a one-to-one mapping between the network elements and the end user services for PABX. Semaphore services are fed by the specific semaphore assets and an IN-contribution via the NLS_Paging. This IN contribution is zero since it is since long depreciated and there are no new investments.

The OPS Platform is split towards EUS_OPS National Information Traffic and EUS_OPS International Information Traffic according to the number of calls. On top of that, the traffic costs are added by considering these calls as an average as interzonal A traffic.

14 Top-Down Data Model

14.1 Introduction

This chapter highlights how the allocation keys between the Network Elements (NE) and the Network Layer Services (NLS) for the data networks are determined.

The main data network at Belgacom is the ATM network. The ATM network is used to implement data connectivity (also called Virtual Paths) between data access equipment and data edge equipment where the end-user services are provided. Data access equipment are ADSL/SDSL bitstream aggregations equipment (also called DSLAM), data edge equipment are Broadband Access Servers (referred to under the acronym "BAS"), IP-VPN/MPLS routers, VideoOnDemand routers. In addition, pure data connectivity is also provided to interconnect LAN at distant customer sites.

Since 2002 Belgacom has the obligation to transport xDSL bitstreams for OLOs to local or to regional ATM switches. This regional connectivity is ensured through the ATM technology.

Swibel is a data network used for network supervision, and is at service of other products and services of the transmission, switching and data network.

Recently, Belgacom invested in Ethernet/MPLS technology which will later take over the functions currently ensured by the ATM network and the SDH transmission network. Therefore the costs related to these new investments are isolated in the model and parked in a specific pool.

Except these new investments, the overall data network architecture is now aligned as much as possible with the BIPT model and with the underlying assumptions for BROBA model.

Different components can be identified:

- The DSLAM network composed of the DSLAM equipment and the DSLAM-ATM regional backhaul links.
- The Regional ATM networks composed of the local ATM switches, the Area ATM switches and the ATM-ATM regional&core backhaul links between local and area switches. In fact there are 8 regional networks corresponding to the 8 interconnect areas used also in BRIO.
In accordance to the BIPT BROBA model, these Regional networks implement data Virtual Paths (VPs) of different capacity. The BIPT model differentiates local VPs and non-local VPs; local VPs establish data connectivity from a port on a switch (local or area) and another port of the same switch; non-local VPs establish data connectivity from a port in a local switch to a port of an area switch.
- The ATM-ATM express backhaul links ensure data connectivity between the areas.
- The various data edge equipment implementing layer 3 functions and higher level services (Broadband Access Servers for IP routing and traffic policing , Video On Demand servers , IP-VPN routers for MPLS based VPN services, etc.).
- The access ports on the regional ATM networks granting physical access to the data VPs of the regional ATM networks.

Similarly to the other network technologies and domains (transmission, switching, access copper), the data network model is a step wise allocation flow starting from direct cost sources (data equipment assets) crosses 12 intermediate steps ending up at the End User Services level .

The numerous intermediate steps are necessary in order to allow other network domains to contribute to the data network construction: the transmission network allocation flow provides the capacity links between data equipment (available at NLS1 level), the network activities allocation flow provides the data network staff related costs (available at PRIMARY_ACT level), the logistics allocation flow provides the accommodation costs related to the data equipment (available at CP3 level).

The global allocation view is presented in Figure 14.

Four main streams can be separated: the ATM resources stream, the data access equipment stream, the data edge equipment stream and the copper line stream (for xDSL services).

14.2 ATM data allocation stream

As described above, the ATM network provides regional transport capacity as Virtual Paths (VP) subject to the BIPT BROBA model; the allocation flow has been aligned on the BIPT BROBA model objects.

14.2.1 From Assets to cost pools

The ATM allocation stream originates at the asset valuation level. The ATM asset is decomposed in regional ATM VP switching (backbone equipment) and in ATM access interfaces.

The asset cost (CAPEX cost) of the VP switching component is based on the inventory of VPs configured on the ATM network using the BIPT BROBA tariff (only the ATM CAPEX component of the tariff, the OPEX and backhaul components have been extracted). Because BIPT BROBA tariffs per VP are purely cost oriented, they provide a convenient way to derive the CAPEX cost of each VP.

The asset cost (CAPEX cost) of the ATM access interface components is based on the inventory of tributary trunks ending on an ATM switch (the regional inter-switch trunks are not in the scope as they are part of the BROBA VP switching component). These tributaries link the data equipment from outside the ATM network to the ATM network.

The two constituents of the ATM asset are separated in two cost pools: ATM Backbone Equipment and ATM Access interface.

14.2.2 ATM regional network and ATM regional tributaries (CP2-NLS3 allocation steps)

As the *ATM Backbone Equipment* cost pool carries the investment costs of all regional VPs, the costs are simply propagated in different steps to *ATM Regional Transport* devoted to represent the ATM regional networks.

In the intermediate steps, then *ATM Regional Transport* is completed with building and power related costs, OPEX costs and the regional interswitch backhaul costs (only the backhaul transmission costs, not the ATM interfaces).

The *ATM access interfaces* cost pool carries the investment costs of ATM interfaces for all ATM tributaries: these are the data links between non ATM data equipment or customer CPE data equipment and the regional ATM networks. Also the interfaces allowing to leave a regional ATM network and to enter another regional ATM network are members of the tributaries. Note that the ATM interfaces for the regional links between ATM switches of a same regional ATM network are thus not included in the tributaries.

The *ATM access interfaces* cost pool is distributed towards the backhaul capacities of these data links. The driver used is the “%Invest_of_consumed_interfaces”: the percentage of investment value of the interface capacities occupied by those links.

14.2.3 ATM based services and constitution of Monitoring network DCN-Swibel (NLS3-NLS4 allocation step)

The purpose of this allocation step is to eliminate the ATM tributary data trunks to the different service platforms and to attribute the ATM regional networks object *ATM Regional Transport* to the service transported on it.

Except for *DATA Trunk ATM-DSLAM* and for *DATA Trunk ATM-ATM Express*, the tributary data trunk can be directly associated to a technical service.

Driver: Direct

14.2.3.1 DATA Trunk ATM-DSLAM:

The network layer service *DATA Trunk ATM-DSLAM* models the links between the DSLAMs and the closest ATM switch of the ATM regional network. These links are the DSLAM-ATM backhaul links also modelled in the BIPT BROBA model: the BIPT model allocates a portion of these costs to “BROBA-end-user-line”. The “BROBA-end-user-line” is represented in the data model by the Network Layer Service *xDSL_Connectivity*.

Driver: bandwidth_used

In the BIPT model, the portion of the ATM-DSLAM backhaul link cost to end user line is calculated as the ratio between the bandwidth used by xDSL services versus the bandwidth installed for xDSL services. This ratio is taken over in our data model.

14.2.3.2 DATA Trunk ATM-ATM Express:

The network layer service *DATA Trunk ATM-ATM Express* captures the links between the ATM switches at area level (non local switches). As opposed to the previous ones, these links are not in the scope of the BIPT BROBA model.

Driver: %VPBandwidth

The cost of these links is distributed to various services as a percentage of the amount (cumulated bandwidth) of inter-area VPs configured for these services. The source used to compute these amounts is the ATM inventory database from the Umbrella operational inventory system.

14.2.3.3 ATM Regional Transport

The ATM regional transport networks are fully constituted (all components required to build the network are present in the modelled object) at NLS3 level to provide the network function in *ATM Regional Transport*. The costs are now allocated to all services using the Regional transport.

Driver: VP_valuation

This is done based on the value of the regional VPs configured on the regional ATM network for the different service categories. The CAPEX VP valuation has already been used to calculate the value of the backbone VP switching component of the ATM network asset. This component is completely included in *ATM_Regional_Transport*. Using the value of used regional VPs as driver succeeds to deaggregate a large part of the NLS3 cost (ATM equip part) in the categories of services defined hereabove and also it succeeds

to take into account VP characteristics like Peak Cell Rate, the Sustained Cell Rate, the Quality of Service, and the distance aspect (local, non-local) that also do impact costs of other cost contributors.

14.2.3.4 Swibel (NLS4 allocation level)

For monitoring and administration of network equipment purposes, an internal IP Data Communication Network is built to interconnect Operation Support Systems (OSS), Mediation Devices and the numerous network equipments. This internal network is named Swibel and is made of IP routers interconnected by backhaul lines (internal leased lines) configured on the transmission network and by ATM regional VPs. At the NLS3 level of allocation all ingredients for the Swibel network are present (transmission backhaul appear at NLS1, dedicated IP routers at CP3, ATM regional VPs at NLS3).

14.2.4 Monitoring the network (NLS4-NLS5 allocation step)

The purpose of this allocation step is to eliminate the DCN-Swibel cost object and to allocate it to the various networks or service platforms according to the number of equipments monitored.

Driver: #TMN_points

The estimated amount of equipments having a Telecommunication Management Network- IP stack in each category. These amounts are retrieved from the network inventory system.

14.2.5 BROBA, Access to Internet, Access to Explore services (NLS5-NLS6 allocation step)

The purpose of this allocation step is to eliminate the remaining technical objects of the data network to come to full network services. At this stage, 4 technical blocks remain:

Swibel_transmission
Swibel_switching
xDSL_ATM_Regional_Transport
xDSL_Connectivity

14.2.5.1 Swibel_transmission

The costs of the Data Communication Network devoted to the administration of the transmission network are allocated to the services delivered by the transmission network that is the large variety of leased capacities (leased lines, access lines to data networks (IP-VPN), interconnect links, PRAs, etc). Note that these costs are particularly required to guarantee the Service Level Agreements with the customers.

Driver: Cumulated Nbr visited transmission functions

The allocation is based on a measure of the amount of equipment that needs to be monitored for a given service. The more equipments must be monitored the more alarm traffic will occur in case of problems. From the inventory system, the detailed routing configuration data has been used to compute the cumulated nbr of equipments involved in the different leased capacities.

14.2.5.2 Swibel_switching

The costs of the Data Communication Network devoted to the administration of the voice switching network are allocated to the various voice traffic types delivered by the switching network.

Driver: Volume of successful calls

14.2.5.3 xDSL_ATM_Regional_Transport

As a result of the allocation flow, the *xDSL_ATM_Regional_Transport* object records the costs of all VPs dedicated to ADSL, SDSL services (access to internet, access to BILAN or IPVPN, BROBA VPs, VoIP, VoD). In this allocation step, this cost is split in their contribution to a variety of broadband services.

Driver: VP_valuation

Similarly to section 14.2.3.3 and for the same reasons as exposed in that section, the value of the regional VPs configured on the regional ATM network for the different services is used as driver .

14.3 Data access equipment stream

The data access equipment stream treats the costs related to the ADSL/SDSL broadband connectivity service (also called bitstream service). Data access equipment stream considers the costs between and including the DSLAMs and the access ports to the ATM switches. In the model the broadband connectivity service (or bitstream) is captured as *xDSL_connectivity* (at NLS4 level).

14.3.1 From AC1/AC2 to NLS4: the network ADSL/SDSL bitstream service

The stream originates in the asset AC1546 accounting for the investment in DSLAM equipment and goes straightforward up to *NLS4_xDSL_connectivity*. Intermediate allocation levels (CP1-to-NLS4) serve to complete the *NLS4_xDSL_connectivity* service with other components originating from other streams: Network Primary activities, backhaul links between DSLAM-ATM (see section 14.2.3.1), building and powering costs at CP2 level.

14.3.2 From NLS4 to NLS5: shift

One to one allocation (100%); no special split treatment or enrichment in this allocation step: it is introduced to synchronise the data access equipment stream with the ATM allocation stream.

14.3.3 From NLS5 to NLS6: ADSL/SDSL bitstream for Retail and Wholesale

In this step the costs of the network bitstream service *NLS5_xDSL_connectivity* are split in a variety of wholesale and retail services bitstream services.

Driver: Volumes in bitstream lines of each NLS6 category.

14.3.4 From NLS6 to EUS: Retail and Wholesale ATM based services

Eventually, in a last step the broadband ADSL/SDSL services being fully constituted at NLS6 level are now split into specific retail and wholesale products based on the volumes in the respective markets.

Driver: Volume in lines in respective products.

14.4 Data edge equipment stream

The data edge equipment (Broadband Access Server-BAS, Internet Management Server - IMS) stream is quite straightforward and runs directly from the specific assets accounting for their investment towards the end level services which are the retail/wholesale xDSL fast internet services. The BAS and IMS equipments are a direct cost to the variety of retail/wholesale xDSL services and are distributed according to their volume.

14.5 Copper line stream for data services

The copper line stream originates in the copper access domain (see section 10) up to the NLS1 level of allocation and flows directly towards the end level services which are retail/wholesale xDSL fast internet services and the BROBA –End User Line service. The copper line is a direct cost to the variety of xDSL services and is distributed according to the consumption of copper lines by the respective xDSL services.

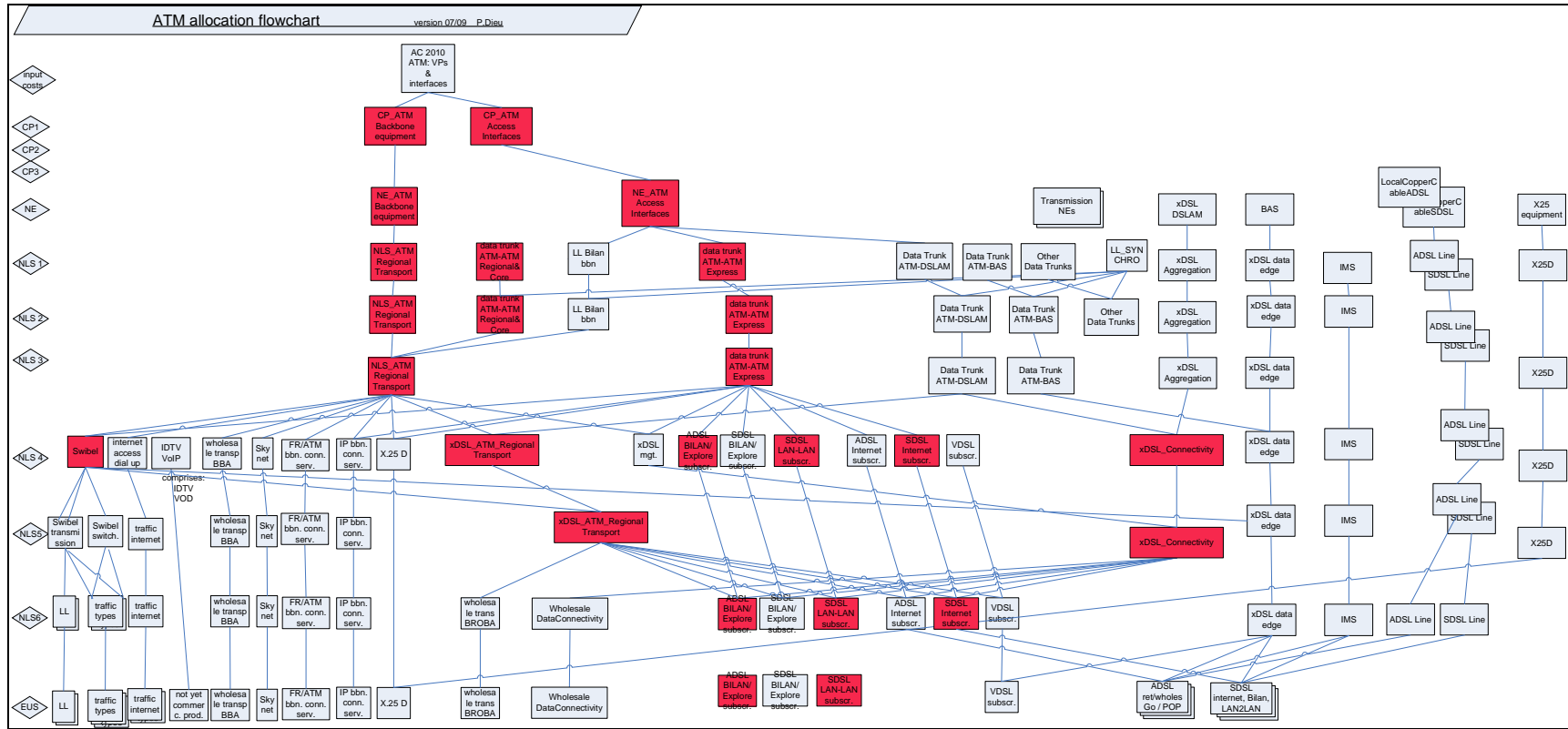

Figure 14 - Data ATM allocation flow

15 IT CAPEX cost allocation stream

The IT CAPEX cost for the model 2008 amounts to the sum of the depreciation of 2008 and the WACC (weighted average cost of capital) of 11,2% applied to the Net Book Value (NBV).

The depreciation 2008 and NBV of the following asset classes categories are considered:

- 1724 Network Management-SW-Configuration&Routing Manag.
- 1731 TMN-Trouble ticketing&fault management (Netcool)
- 25 xx
- 44 xx

Those asset classes are exclusively identified as “IT. All assets of those categories are depreciated over 4 years. Each of these assets is allocated to the unique IT activity “7.2.3. *Develop IT applications (CAPEX mandays) / capitalised IT material*”.

These costs are pooled together with other IT costs in one unique IT pool named “*ALL IT COSTS (CAPEX+OPEX)*”.