

B I P T

**BELGISCH INSTITUUT VOOR POSTDIENSTEN
EN TELECOMMUNICATIE**

**BESLUIT VAN DE RAAD VAN HET BIPT
VAN 11 AUGUSTUS 2014
BETREFFENDE
HET ADDENDUM BIJ HET REFERENTIEAANBOD
BROTSOLL BETREFFENDE HUURLIJNEN VAN DE
NIEUWE GENERATIE (NGLL)**

INHOUDSOPGAVE

1.	INLEIDING	4
1.1	RETROACTA	4
1.2	VOORAFGAANDE RAADPLEGINGSPROCEDURE	4
1.3	NATIONALE RAADPLEGINGSPROCEDURE	5
	1.3.1 <i>Wettelijke basis</i>	5
	1.3.2 <i>Resultaten van de raadpleging</i>	6
1.4	INSTITUTIONELE RAADPLEGINGEN	6
	1.4.1 <i>Raadpleging van de mediaregulatoren</i>	6
	1.4.1.1 <i>Wettelijke basis</i>	6
	1.4.1.2 <i>Resultaten van de raadpleging</i>	7
	1.4.2 <i>Europese raadpleging</i>	7
	1.4.2.1 <i>Wettelijke basis</i>	7
	1.4.2.2 <i>Resultaten van de raadpleging</i>	8
1.5	JURIDISCH KADER.....	8
2	ANALYSE	10
2.1	NIET-OPNAME VAN DE DIENST "TRANSPARENT" (VPLS-T MODE)	10
	2.1.1 <i>Probleemstelling</i>	10
	2.1.2 <i>Reactie(s)</i>	10
	2.1.3 <i>Analyse van het BIPT en conclusie</i>	10
2.2	GEBRUIKSBEPERKINGEN VOOR SOMMIGE VLAN'S	11
	2.2.1 <i>Probleemstelling</i>	11
	2.2.2 <i>Reactie(s)</i>	11
	2.2.3 <i>Analyse van het BIPT en conclusie</i>	11
2.3	GEBRUIK VAN EEN ETHERNET-SWITCH BIJ DE EINDKLANT EN OP HET NIVEAU VAN HET AGGREGATIEPUNT VAN DE ALTERNATIEVE OPERATOR	12
	2.3.1 <i>Probleemstelling</i>	12
	2.3.2 <i>Reactie(s)</i>	12
	2.3.3 <i>Analyse van het BIPT en conclusie</i>	12
2.4	ADDENDUM "FEASIBILITY FEEDBACK AND TIMING ESTIMATES FOR FIBER INSTALLATION"	13
	2.4.1 <i>Probleemstelling</i>	13
	2.4.2 <i>Reactie(s)</i>	14
	2.4.3 <i>Analyse van het BIPT en conclusie</i>	14
2.5	SLA'S (SERVICE LEVEL AGREEMENTS)	14
	2.5.1 <i>Probleemstelling</i>	14
	2.5.2 <i>Reactie(s)</i>	15
	2.5.3 <i>Analyse van het BIPT en conclusie</i>	15
2.6	UITFASERING	16
	2.6.1 <i>Probleemstelling</i>	16
	2.6.2 <i>Reactie(s)</i>	16
	2.6.3 <i>Analyse van het BIPT en conclusie</i>	16
2.7	VERZOEK OM PRIJSOPGAVE VOOR AANSLUITING OP GLASVEZEL	16
	2.7.1 <i>Probleemstelling</i>	16
	2.7.2 <i>Reactie(s)</i>	17
	2.7.3 <i>Analyse van het BIPT en conclusie</i>	17
2.8	BEVEILIGING OPTIONS FOR PARTIAL CIRCUITS AND BACKHAULS	17
	2.8.1 <i>Probleemstelling</i>	17
	2.8.2 <i>Reactie(s)</i>	17
	2.8.3 <i>Analyse van het BIPT</i>	17

2.9	TOEGANG TOT DE "MANHOLES"	17
3	BESLUIT	18
4	BEROEPSMOGELIJKHEDEN	20
BIJLAGE A.	VOORSTEL VAN BELGACOM VOOR EEN ADDENDUM BIJ HET REFERENTIEAANBOD	
BROTSOLL	21	

1. INLEIDING

1.1 RETROACTA

1. In zijn besluit van 8 augustus 2013 betreffende de analyse van de huurlijnenmarkten heeft het BIPT Belgacom verplicht tot de publicatie van een referentieaanbod voor een transportdienst gebaseerd op de Ethernet-technologie ("NGLL" of "Next Generation Leased Lines", zie § 4:10.1) met de mogelijkheid tot een technologische keuze zolang de DWDM/SDH-infrastructuur operationeel is (§ 4.163).
2. Overeenkomstig artikel 59, § 2 en § 3, van de wet van 13 juni 2005 betreffende de elektronische communicatie, heeft het besluit van het BIPT van 8 augustus 2013 betreffende de analyse van de huurlijnenmarkten de verplichting voor Belgacom behouden tot publicatie van een referentieaanbod betreffende de verrichtingen inzake toegang en interconnectie die nodig zijn voor de levering van afgevend segmenten van huurlijnen (§ 4.268). Dit referentieaanbod moet de klassieke huurlijnen en de "NGLL"-lijnen omvatten (§ 4.269).
3. Het voorstel voor een referentieaanbod is door Belgacom naar het BIPT overgezonden op 20 november 2013. Dat bevatte:
 - 3.1. het hoofdgedeelte van het aangepaste BROTSoLL-referentieaanbod, dat enkele kleine verschrijvingen rechtzet;
 - 3.2. een addendum bij het referentieaanbod voor de prijsopgaven voor de aansluiting op een gebouw door middel van glasvezel;
 - 3.3. bijlage 4, Pricing NGLL;
 - 3.4. bijlage 5, Technical specifications NGLL.
4. Het voorstel van Belgacom heeft betrekking op de kwalitatieve en kwantitatieve aspecten van de NGLL-lijnen. Dit ontwerpbesluit slaat echter alleen op de kwalitatieve aspecten. De tarieven van de NGLL-lijnen zullen worden behandeld in een later besluit.

1.2 VOORAFGAANDE RAADPLEGINGSPROCEDURE

5. Het geheel van de documenten die zijn voorgesteld door Belgacom is voor commentaar voorgelegd aan de sector van 28 november tot 18 december 2013 via e-mail (voorafgaande raadpleging).
6. Na afloop van deze voorafgaande raadpleging heeft het BIPT de opmerkingen ontvangen van het Platform Telecom Operators & Service Providers en van Belcenter.

1.3 NATIONALE RAADPLEGINGSPROCEDURE

1.3.1 Wettelijke basis

7. De nationale raadpleging wordt georganiseerd op basis van artikel 6 van de Kaderrichtlijn¹:

"Behalve in gevallen die vallen onder artikel 7, lid 9, artikel 20 of artikel 21, zorgen de lidstaten ervoor dat, wanneer de nationale regelgevende instanties voornemens zijn krachtens deze richtlijn of de bijzondere richtlijnen maatregelen te nemen, dan wel wanneer zij voornemens zijn krachtens artikel 9, leden 3 en 4, beperkingen vast te stellen die een belangrijke impact op de betrokken markt hebben, de belanghebbende partijen de mogelijkheid wordt geboden binnen een redelijke periode opmerkingen over de ontwerpmaatregel in te dienen. [...]"

"De resultaten van de raadpleging worden door de nationale regelgevende instanties openbaar gemaakt, behalve in geval van vertrouwelijke informatie overeenkomstig het communautair en nationaal recht betreffende zakelijke vertrouwelijkheid."

8. De Belgische wetgeving beoogt de organisatie van een dergelijke nationale raadpleging in de artikelen 139 en 140 van de wet van 13 juni 2005, en die zijn dus ook in dit geval van toepassing:

"Art. 139. Het Instituut kan voor de toepassing van deze wet een openbare raadpleging houden overeenkomstig artikel 14 van de wet van 17 januari 2003 met betrekking tot het statuut van de regulator van de Belgische post- en telecommunicatiesector."

"Art. 140. Voor zover een ontwerpbeslissing van het Instituut aanzienlijke gevolgen zou kunnen hebben voor een relevante markt, organiseert het Instituut een voorafgaande openbare raadpleging met een maximale tijdsduur van twee maanden, met inachtneming van de regels inzake vertrouwelijkheid van de bedrijfsgegevens."

Alle inlichtingen in verband met aan de gang zijnde openbare raadplegingen worden bij het Instituut gecentraliseerd."

De resultaten van de openbare raadpleging worden openbaar gemaakt, met inachtneming van de regels inzake vertrouwelijkheid van de bedrijfsgegevens."

De Koning bepaalt, na advies van het Instituut, de nadere regels van de openbare raadpleging en van de bekendmaking van de resultaten ervan."

¹ Richtlijn 2002/21/EG van het Europees Parlement en de Raad van 7 maart 2002 inzake een gemeenschappelijk regelgevingskader voor elektronische-communicatienetwerken en -diensten.

1.3.2 Resultaten van de raadpleging

9. Het ontwerpbesluit is voor nationale raadpleging voorgelegd van 7/02/2014 tot 5/03/2014. Daarbij zijn aan het BIPT opmerkingen meegedeeld door Belgacom, het Platform Telecom Operators en Belcenter.
10. De antwoorden op deze nationale raadpleging zijn opgenomen in deel 2 in elk van de paragrafen die overeenstemmen met de opmerkingen.

1.4 INSTITUTIONELE RAADPLEGINGEN

1.4.1 Raadpleging van de mediaregulatoren

1.4.1.1 Wettelijke basis

11. Na de nationale raadpleging en rekening houdend met de resulterende reacties werd het op 22 mei 2014 gewijzigde ontwerpbesluit toegezonden aan de gemeenschapsregulatoren (CSA, VRM, Medienrat) op 27 mei 2014 in overeenstemming met artikel 3, eerste lid, van het samenwerkingsakkoord van 17 november 2006²:

"Art. 3. Elke ontwerpbeslissing van een regulerende instantie die betrekking heeft op elektronischecommunicatienetwerken wordt door de desbetreffende instantie overgemaakt aan de andere regulerende instanties die zijn opgesomd in artikel 2, 2°, van dit samenwerkingsakkoord.

De regulerende instanties die geconsulteerd worden bezorgen binnen de 14 kalenderdagen hun opmerkingen aan de regulerende instantie die de ontwerpbeslissing heeft overgemaakt. Binnen deze termijn kan elk van de regulerende instanties die geconsulteerd worden vragen dat de ontwerpbeslissing aanhangig wordt gemaakt bij de Conferentie van Regulatoren voor de Elektronische-Communicatiesector (hierna genoemd de CRC). Dit verzoek tot onmiddellijke overmaking aan de CRC wordt gemotiveerd.

De betrokken regulerende instantie neemt de opmerkingen in aanmerking die de andere regulerende instanties eraan bezorgd hebben en maakt de gewijzigde ontwerpbeslissing over aan de andere regulerende instanties. Deze laatste beschikken na ontvangst van de gewijzigde ontwerpbeslissing over een termijn van 7 kalenderdagen waarbinnen zij kunnen vragen dat de gewijzigde ontwerpbeslissing aanhangig wordt gemaakt bij de CRC.

Na afloop van de in het tweede en derde lid voorziene termijn wordt de ontwerpbeslissing geacht, behoudens tegenbewijs, geen afbreuk te doen aan de bevoegdheden van de andere regulerende instanties."

² Samenwerkingsakkoord van 17 november 2006 tussen de Federale Staat, de Vlaamse Gemeenschap, de Franstalige Gemeenschap en de Duitstalige Gemeenschap betreffende het wederzijds consulteren bij het opstellen van regelgeving inzake elektronischecommunicatienetwerken, het uitwisselen van informatie en de uitoefening van de bevoegdheden met betrekking tot elektronischecommunicatienetwerken door de regulerende instanties bevoegd voor telecommunicatie of radio-omroep en televisie, BS 28 december 2006, p. 75371; ook beschikbaar op www.bipt.be.

1.4.1.2 Resultaten van de raadpleging

12. Het ontwerpbesluit en zijn bijlages zijn overgezonden aan de mediaregulatoren op 27 mei 2014. Zowel de CSA als de VRM antwoordden geen opmerkingen te hebben door middel van een brief op 10 resp. 16 juni. De Medienrat verkoos niet te antwoorden. Het BIPT besluit daaruit dat het ontwerpbesluit geen afbreuk doet aan de bevoegdheden van de andere regulatoren.

1.4.2 Europese raadpleging

1.4.2.1 Wettelijke basis

13. Op 4 juli is het aangepaste ontwerpbesluit overgezonden aan de Europese Commissie, aan BEREC en aan de nationale regelgevende instanties (NRI's) van de andere lidstaten conform artikel 7 van de Kaderrichtlijn³:

"3. Behalve wanneer anders bepaald in aanbevelingen of richtsnoeren die zijn vastgesteld op grond van artikel 7 ter, nadat de in artikel 6 bedoelde raadpleging is afgesloten, maakt een nationale regelgevende instantie, wanneer zij voornemens is een maatregel te nemen die:

1. valt binnen de draagwijdte van de artikelen 15 of 16 van deze richtlijn of de artikelen 5 of 8 van Richtlijn 2002/19/EG (toegangsrichtlijn); en
2. van aanzienlijke invloed is op de handel tussen de lidstaten,

de ontwerpmaatregel tegelijkertijd toegankelijk is voor de Commissie, BEREC en de nationale regelgevende instanties in andere lidstaten, vergezeld van een motivering, overeenkomstig artikel 5, lid 3, en brengt zij de Commissie, BEREC en de andere nationale regelgevende instanties daarvan op de hoogte. De nationale regelgevende instanties, BEREC en de Commissie krijgen een maand de tijd om opmerkingen in te dienen bij de nationale regelgevende instantie in kwestie. De periode van één maand kan niet worden verlengd. "

14. Artikel 141 van de wet van 13 juni 2005 bepaalt dat de Europese Commissie, BEREC en de nationale regelgevende instanties van de lidstaten als volgt moeten worden geraadpleegd:

"Art. 141. § 1. Voor zover een ontwerpbeslissing van het Instituut invloed kan hebben op de handel tussen de lidstaten en erop gericht is:

[...]

6° de wijziging van het referentieaanbod op te leggen, overeenkomstig artikel 59, § 4,

³ Richtlijn 2002/21/EG van het Europees Parlement en de Raad van 7 maart 2002 inzake een gemeenschappelijk regelgevingskader voor elektronische-communicatienetwerken en -diensten.

[...] raadpleegt het Instituut de Europese Commissie, BEREC en de nationale regelgevende instanties van de lidstaten.

[...]

§ 2. Het Instituut houdt zoveel als mogelijk rekening met de opmerkingen die het binnen de maand van de kennisgeving van de ontwerpbeslissing zijn toegezonden door de Europese Commissie, BEREC en de nationale regelgevende instanties van de lidstaten. "

1.4.2.2 Resultaten van de raadpleging

15. Het op 4 juli overgezonden ontwerpbesluit is geregistreerd als de zaak BE/2014/1640. De Europese Commissie deed op 10 juli het BIPT een verzoek om informatie toekomen, waarop het antwoord werd verstuurd op 14 juli.
16. De Europese Commissie zond haar besluit op 31 juli 2014. Zij had geen opmerkingen op het ontwerpbesluit.

1.5 JURIDISCH KADER

17. De wet van 13 juni 2005 betreffende de elektronische communicatie bepaalt dat operatoren met een sterke machtspositie op een markt na afloop van de analyse van deze markt (onder meer) verplichtingen kunnen worden opgelegd inzake toegang, niet-discriminatie, kostenbasing en transparantie.
18. Deze verplichtingen zijn aan Belgacom opgelegd, overeenkomstig het besluit van het BIPT van 8 augustus 2013. Om zich ervan te vergewissen dat deze verplichtingen wel degelijk worden nagekomen door Belgacom, wordt deze laatste ook verplicht om een referentieaanbod op te stellen voor een transportdienst die gebaseerd is op de Ethernet-technologie.
19. Het doel van de publicatie van een referentieaanbod is om duidelijkheid te bieden omtrent de voorwaarden waaraan voldaan moet worden om de diensten van de operator met een sterke machtspositie te kunnen genieten en om voldoende op voorhand te kunnen beoordelen of deze voorwaarden wel redelijk zijn. Overeenkomstig artikel 59, § 2, van de wet van 13 juni 2005 moet het referentieaanbod bovendien voldoende gedetailleerd en volledig zijn om te garanderen dat de operatoren geen middelen moeten betalen die niet nodig zijn voor de gewenste dienst. Hetzelfde artikel bepaalt verder nog: *"[In het referentieaanbod] wordt een beschrijving gegeven van de betrokken aanbiedingen, uitgesplitst in diverse elementen naargelang de marktbehoeften en de daaraan verbonden eisen en voorwaarden, met inbegrip van de tarieven"*.
20. Overeenkomstig artikel 59, § 5, van de wet betreffende de elektronische communicatie kan het BIPT het referentieaanbod wijzigen om de wettelijk bepaalde maatregelen op te leggen. Het referentieaanbod moet ook up-to-date gehouden worden. Overeenkomstig

artikel 59, § 5, van de wet van 13 juni 2005 moet het BIPT het referentieaanbod te allen tijde kunnen wijzigen om rekening te houden met de ontwikkeling van de Belgacom-aanbiedingen en de verzoeken van de alternatieve operatoren. Belgacom is verplicht om de verzoeken van het BIPT om publicatie van bijkomende elementen in te willigen.

21. Zoals artikel 59, § 4, eerste lid, van de wet betreffende de elektronische communicatie voorschrijft, moet het referentieaanbod door het BIPT worden goedgekeurd voordat het gepubliceerd wordt. Volgens artikel 59, §6 moet het BIPT in kennis worden gesteld van elke door Belgacom voorgestelde wijziging van het referentieaanbod ten minste 90 dagen voor het tijdstip waarop de wijziging in werking zou treden. Binnen die termijn kan het BIPT Belgacom meedelen dat het van plan is een besluit te nemen, wat de inwerkingtreding van de gewenste wijziging opschort. Het BIPT mag tevens alle aanpassingen opleggen die het nodig acht.
22. Tot slot legt het besluit van het BIPT van 08 augustus 2013 de volgende termijnen op (4 :270) voor de procedure volgens welke Belgacom de wholesaleoplossing moet voorleggen en ze operationeel maken:

"Uiterlijk 3 maanden na de publicatie van dit besluit moet Belgacom aan het BIPT een voorstel tot aanpassing van het referentieaanbod bezorgen waarin de NGLL-lijnen vervat zijn. Het BIPT zal vervolgens een of meer besluiten aannemen met betrekking tot de kwalitatieve en kwantitatieve aspecten van het voorstel voor een referentieaanbod. Het referentieaanbod zal operationeel moeten zijn uiterlijk 6 maanden na het besluit van het BIPT betreffende ten minste de kwalitatieve aspecten van het voorstel."

2 ANALYSE

23. Na zijn analyse van het voorstel voor een referentieaanbod en na de opmerkingen die ontvangen zijn tijdens de raadplegingsprocedure komt het BIPT tot de onderstaande conclusies.

2.1 NIET-OPNAME VAN DE DIENST "TRANSPARENT" (VPLS-T MODE)

2.1.1 Probleemstelling

24. In artikel 2, 30°, van de wet van 13 juni 2005 wordt een huurlijn gedefinieerd als “een elektronische communicatiedienst bestaande uit de levering van communicatiefaciliteiten met behulp waarvan transparante transmissiecapaciteit tussen netwerkaansluitpunten wordt geboden, met uitzondering van de schakeling op aanvraag”.
25. In het besluit van 8 augustus 2013 is geconcludeerd dat, gelet op de karakteristieken ervan (met name de transparantie), de NGLL-lijnen en de klassieke huurlijnen voldoende substitueerbaar waren om deel uit te maken van dezelfde productmarkt.
26. In zijn retailaanbod "Explore" definieert en biedt Belgacom twee soorten dienst: “Transparent” (of VPLS-T mode) en “VLAN based” (of VPLS-V mode) ⁴ Belgacom biedt de eerste dienst niet aan in zijn referentieaanbod voor de wholesalemarkt, terwijl deze dienst van nature beantwoordt aan de specificatie van transparantie die in de marktanalyse wordt gevraagd.

2.1.2 Reactie(s)

27. Belgacom heeft in zijn antwoord op de raadpleging laten weten dat het BROTSoLL-aanbod op een soortgelijke wijze geconfigureerd is als het aanbod VPLS-T Mode. Het preciseert bovendien dat de term “transparent” die wordt gebruikt om die “modus” te definiëren niet verwijst naar het feit dat die minder blokkeringen zou bieden voor de verschillende protocollen dan de VPLS-V Mode maar naar het feit dat de begunstigde de vrije keuze heeft van de nummering van de VLAN's.

2.1.3 Analyse van het BIPT en conclusie

28. Het BIPT leidt daaruit af dat het op de wholesale markt aangeboden product een zelfde transparantieniveau biedt ten aanzien van de protocollen en dus voldoet aan de vereisten in het marktanalysebesluit. Rekening houdende met de hierboven uiteengezette verduidelijking van Belgacom vindt het BIPT dat het aanbod daadwerkelijk beantwoordt aan de behoeften van de begunstigden en er derhalve geen wijziging nodig is van het ontwerp-referentieaanbod.

⁴ Brochure Belgacom "Service description Explore Ethernet VPN" van 28/09/2011

2.2 GEBRUIKSBEPERKINGEN VOOR SOMMIGE VLAN'S

2.2.1 Probleemstelling

29. Belgacom vermeldt gebruiksbeperkingen voor een groter aantal VLAN's dan in het aanbod WBA VDSL2 (zie p. 11 "VLAN limitation" van bijlage 5 bij het referentieaanbod in bijlage A).
30. Zoals uiteengezet in randnummer 4:78 van het marktanalysebesluit, maken de NGLL-lijnen geen gebruik van de ISAM-DSLAM's van Alcatel, noch de VDSL2-modems, en ze gebruiken geen apparatuur van laag 2 of 3 die niet door WBA wordt gebruikt. Er is dus geen verklaring voor de extra beperkingen ten opzichte van het aanbod WBA VDSL2.
31. Het BIPT vindt dat de beperkingen inzake gebruik van de VLAN's door objectieve elementen moeten worden gerechtvaardigd.
32. Bovendien vraagt een respondent te verduidelijken dat de OLO wel degelijk de volledige keuze van zijn VLAN's heeft en dat de keuzes van de sites ID, STAG en CTAG (zie p. 11 "NGLL" van bijlage 5 bij het referentieaanbod in de bijlage) wel degelijk losstaan van elkaar zonder andere beperkingen dan die welke in het aanbod zijn vermeld.

2.2.2 Reactie(s)

33. Belgacom rechtvaardigt de beperkingen in het gebruik van de VLAN's door de behoeften inzake beheer van de apparatuur die door Belgacom geïnstalleerd is aan de uiteinden van de lijnen.

2.2.3 Analyse van het BIPT en conclusie

34. Het BIPT is van oordeel dat Belgacom de gevraagde objectieve rechtvaardigingen heeft gegeven door het gebruik dat het er zelf van maakt te verduidelijken: VLAN 999 is voorbehouden voor het management van de CPE switch en de VLAN's 1000-1005 worden gebruikt voor intern gebruik van de CPE switch van Cisco. In dat opzicht hoeft het referentieaanbod dus niet te worden gewijzigd.
35. Voor het gebruik van VLAN 1 verantwoordt Belgacom de beperkingen door te verwijzen naar de waarschuwingen van zijn leverancier, in dit geval Cisco⁵. Een respondent heeft erop gewezen dat dit gebruik mogelijk is in het kader van het commerciële aanbod "Explore Wholesale", dat dezelfde apparatuur gebruikt. Deze reactie is via mail meegedeeld aan Belgacom, dat als volgt geantwoord heeft op 25 april 2014:

⁵ Cisco, VLAN Security White Paper, Precautions for the Use of VLAN 1, document beschikbaar via: http://www.cisco.com/en/US/products/hw/switches/ps708/products_white_paper09186a008013159f.shtml#wp39009.

"op speciaal verzoek en op risico van de operator die dat zou wensen, kunnen we overwegen om ook VLAN 1 open te stellen. Er moet echter worden opgemerkt dat dit in geen geval door Belgacom wordt aanbevolen, dat het in strijd is met de goede praktijken die worden aanbevolen door Cisco (cf. white paper hieronder in de mail) en dat in geval van moeilijkheden door het gebruik van dit VLAN 1 door een operator, Belgacom geenszins aansprakelijk kan worden gesteld voor de ondervonden problemen." (vrij vertaald)

36. Krachtens de verplichting tot non-discriminatie die opgelegd is aan Belgacom in het kader van deze markt (Sectie 4.3.6 van het besluit van 8 augustus 2013 betreffende de analyse van de huurlijnenmarkten) is het BIPT van oordeel dat het gebruik ervan dus ook mogelijk zou moeten zijn in het kader van BROTSoLL, en dit onder dezelfde voorwaarden als bij het aanbod Explore Wholesale. In het referentieaanbod moet Belgacom het verbod om VLAN 1 te gebruiken vervangen door de voorwaarden waaronder het kan worden gebruikt, in overeenstemming met zijn antwoord via mail van 25 april 2014.
37. Het BIPT vindt bovendien dat de vraag in verband met de vrije keuze van de site ID's, STags en CTags (zie p. 11 "NGLL" van bijlage 5 bij het referentieaanbod in de bijlage) gerechtvaardigd en redelijk is, omdat daarvoor geen technische wijziging nodig is in het referentieaanbod en aan het betrokken product. Het BIPT vraagt Belgacom om in de paragraaf "End-Customers sites" te preciseren dat de site ID's, S-Tags en C-Tags door de OLO vrij kunnen worden toegewezen, rekening houdend met de beperkingen die vermeld zijn in de paragraaf "VLAN Limitation".

2.3 GEBUIK VAN EEN ETHERNET-SWITCH BIJ DE EINDKLANT EN OP HET NIVEAU VAN HET AGGREGATIEPUNT VAN DE ALTERNATIEVE OPERATOR

2.3.1 Probleemstelling

38. In de huidige formulering ervan lijkt het deel "Configuring the NGLL service with Aggregation Point and End-Customer Sites" het gebruik op te leggen van een Ethernet-switch bij de eindklant en op het niveau van het aggregatiepunt van de alternatieve operator (zie p. 10 en 11 van bijlage 5); een respondent is van oordeel dat er geen reden is om het type van CPE op te leggen die bij zijn eindklant geïnstalleerd moet worden.

2.3.2 Reactie(s)

39. Belgacom preciseert dat het om zijn eigen apparatuur gaat en dat deze nodig is voor het eind-tot-eind beheer van de dienst. De switch op de OAL (OLO Access Line) is gemeenschappelijk voor alle lijnen die aan de operator worden verstrekt.

2.3.3 Analyse van het BIPT en conclusie

40. Het BIPT stelt vast dat de verduidelijking van Belgacom tegemoetkomt aan de ongerustheid die door de alternatieve operatoren was geuit. Het BIPT vraagt Belgacom niettemin om in het referentieaanbod te verduidelijken dat deze apparatuur door Belgacom wordt geleverd en integraal deel uitmaakt van de NGLL-dienst.

2.4 ADDENDUM “FEASIBILITY FEEDBACK AND TIMING ESTIMATES FOR FIBER INSTALLATION”

2.4.1 Probleemstelling

41. In het besluit van 8 augustus 2013 wordt bepaald dat Belgacom binnen een redelijke termijn en voor een redelijke kostprijs een prijsopgave zal verstrekken voor de aansluiting van gebouwen op zijn glasvezelnetwerk. Elke weigering zal moeten worden gemotiveerd op basis van dezelfde criteria als die welke voor de retailmarkt gelden. (§ 4:177). Er wordt bovendien gepreciseerd dat deze prijsopgave voldoende gedetailleerd zal zijn en dat Belgacom een addendum bij zijn referentieaanbod zal voorstellen in verband met de voorwaarden voor levering van prijsopgaven voor aansluiting op glasvezel; onder andere de termijn die voor de levering van de prijsopgave wordt voorgesteld, moet worden gerechtvaardigd door bewijsstukken.
42. Het voor raadpleging voorgelegde ontwerp van addendum beschrijft enkel de procedure in verband met de prijsopgave en geeft te weinig verduidelijking over de termijnen:
 - 42.1. Belgacom schrijft alleen maar: “Belgacom will provide in a reasonable timeframe, feasibility feedback and timing estimates for fiber installation to connect OLO customer building to Belgacom access network.” (deel 1 van zijn addendum “fiber study”).
 - 42.2. Bovendien schrijft Belgacom in verband met het specifieke geval waarin een gebouw niet aangesloten is op het glasvezelnetwerk van Belgacom (voorwerp van de verplichting vermeld in deel 4.3.5.6 van het besluit van 8 augustus 2013), het volgende: “*The feasibility study might result in extra-cost and extra leadtime in case the OLO end-customer is not connected yet to the Belgacom fiber network.*”.
43. Het BIPT erkent dat er onvoorzienbare omstandigheden kunnen zijn die het beletten om de termijn voor levering van een prijsopgave nauwkeurig te schatten. Belgacom moet echter de procedure in stappen verdelen en een maximumduur bepalen, waardoor het mogelijk zou moeten zijn om op te maken dat de termijn voor de prijsopgave voor aansluiting daadwerkelijk redelijk is, zoals geëist door het voormelde besluit.

2.4.2 Reactie(s)

44. In zijn antwoord op de raadpleging stelt Belgacom de volgende aanpassing voor:

8. Response Timers

75% of the requests for fiber feasibility will be treated in the 5WD
The remaining 25% will be treated in the 10WD

Those timers are given as guidance and might be subject to variation depending on:

- Complexity of the request
- Quality of input
- Exceptional volumes (eg. projects with dozens of sites)

In case of too complex request or missing info from customer, the timers above are no longer valid and Belgacom will inform within the standard delay the customer of the longer delay.

2.4.3 Analyse van het BIPT en conclusie

45. Het BIPT is van mening dat de door Belgacom voorgestelde termijnen kort genoeg zijn zodat een onderverdeling in stappen, zoals gevraagd in het ontwerpbesluit dat voor nationale raadpleging is voorgelegd, niet nodig is. Het BIPT keurt dus goed dat de eerste twee paragrafen worden opgenomen in het referentieaanbod.
46. Wat de derde paragraaf betreft kan het ontbreken van enige aanwijzing inzake duur en de algemeenheid van de term "complex" de bruikbaarheid van voorgestelde timers tenietdoen:
- 46.1. Voor de gevallen van "missing info from customer" moet Belgacom zich ertoe verbinden de begunstigde daarvan op de hoogte te brengen binnen ten hoogste 5 dagen en te preciseren dat de timer begint te lopen vanaf de datum van ontvangst van de volledige informatie, met specificatie van de vereiste inlichtingen.
- 46.2. Wat betreft de gevallen van "too complex request" moet Belgacom binnen 5 dagen de begunstigde laten weten dat zijn verzoek onder deze categorie valt en hem een redelijke termijn toestaan om zijn verzoek te behandelen en daarbij de redenen verduidelijken waarom zijn verzoek onder deze categorie valt.

2.5 SLA's (SERVICE LEVEL AGREEMENTS)

2.5.1 Probleemstelling

47. Het Platform wenst de kwestie van de SLA's meer in detail te bespreken (zie §§ 12 en 13 van het referentieaanbod) met Belgacom en het BIPT. Ter inleiding stelt het de volgende punten voorop:

- 47.1. Noodzaak om de versies van de SLA's te nummeren om ze eenduidig te identificeren;
 - 47.2. Waarborg inzake beschikbaarheid per maand in plaats van per jaar;
 - 47.3. De parameters van de SLA's zijn niet strikt genoeg;
 - 47.4. Noodzaak tot een SLA 7d/7 24 u/24;
 - 47.5. In paragraaf 13.6 is er sprake van "E-line" in plaats van "NGLL";
 - 47.6. Vraag naar operationele verslagen.
48. In het voor raadpleging voorgelegde ontwerpbesluit had het BIPT bovendien verklaard open te staan voor het houden van trilaterale vergaderingen om alle problemen in het kader van deze raadpleging te bespreken. Het BIPT was echter van oordeel dat dergelijke vergaderingen enkel zouden moeten plaatshebben als er werkelijke moeilijkheden waren om een akkoord te bereiken tijdens rechtstreekse gesprekken tussen de alternatieve operatoren en Belgacom.

2.5.2 Reactie(s)

49. Wat de SLA betreft, stelt Belgacom voor om zijn referentieaanbod aan te passen en daaraan twee optionele SLA's toe te voegen die worden aangeboden in zijn "retail"-aanbiedingen (6d/7 15 u/24 en 7d/7 24u/24); daartoe stelt Belgacom de volgende tekst voor:

"As well for the yearly availability as for the other parameters (repair timer 5 hours), the SLA applicable for NGLL is the standard retail SLA. In the retail SLA, some options such as the extension of the intervention window to 7/24 are available at extra costs. This option can be added to the NGLL SLA with the associated cost."

50. Belgacom heeft het BIPT mondeling laten weten dat de rapporten inzake follow-up van SLA's al bestaan en geleverd worden.
51. Het BIPT constateert bovendien dat er tijdens de raadplegingsperiode geen onderhandelingen zijn geweest tussen Belgacom en de alternatieve operatoren.

2.5.3 Analyse van het BIPT en conclusie

52. Het BIPT aanvaardt de tekst die Belgacom heeft voorgesteld in verband met de SLA's voor zover dat daarin een uitdrukkelijke verwijzing wordt toegevoegd naar de SLA 6d/7 15u/24, alsook de hyperlinks waarmee de beschrijving van de SLA's kan worden teruggevonden. In het andere geval zouden de SLA's als bijlage bij het referentieaanbod moeten worden gevoegd.

53. Het BIPT neemt akte van de levering van de rapporten inzake follow-up van SLA's en vraagt om dit uitdrukkelijk te vermelden in het referentieaanbod.
54. Het BIPT vraagt om het gehele document te harmoniseren wat betreft de benaming NGLL of E-Line, naar keuze van Belgacom, om elke bron van verwarring in de terminologie te vermijden.
55. Tenslotte beschikt het BIPT alsnog niet over genoeg informatie om zich uit te spreken over de punten 47.2, 47.2, 47.3 hierboven. Daarover zal beslist worden in een apart besluit.

2.6 UITFASERING

2.6.1 Probleemstelling

56. Wat betreft de eventuele uitfasering van een (deel) van deze aanbiedingen (zie secties 5.3 - wat de aanbiedingen inzake Partial Circuit betreft - en 7.4 - voor het NGLL-aanbod - van het referentieaanbod in de bijlage), herinnert het BIPT eraan dat het besluit van 8 augustus 2013 in paragraaf 4 :221 Belgacom ertoe verplicht een alternatieve oplossing te bieden. De beschouwde secties moeten die verplichting weerspiegelen.

2.6.2 Reactie(s)

57. Belgacom kondigt in zijn bijdrage aan dat het aan deze voorwaarde zal voldoen.

2.6.3 Analyse van het BIPT en conclusie

58. Het BIPT neemt kennis van de verbintenis van Belgacom, dat een tekst ad hoc zal opstellen.

2.7 VERZOEK OM PRIJSOPGAVE VOOR AANSLUITING OP GLASVEZEL

2.7.1 Probleemstelling

59. Het Platform is bezorgd over een vraag naar informatie met meer elementen dan nodig is en over de Chinese Wall die nodig is om ze te beschermen (zie sectie 6 Addendum Fiber Study).
60. Na afloop van de voorafgaande raadpleging vond het BIPT het verzoek om inlichtingen niet buitensporig (behalve dat de lijst volledig moet zijn en dus geen formuleringen mag bevatten zoals "...") en wijst erop dat Belgacom onderworpen is aan een Chinese Wall-verplichting (die voortvloeit uit de non-discrimatieverplichting) voor al zijn gereguleerde wholesaleproducten, zelfs wanneer dat punt niet wordt vermeld in het referentieaanbod.

2.7.2 Reactie(s)

61. Belgacom kondigt in zijn bijdrage aan dat het alle vermeldingen zal verwijderen die de indruk kunnen wekken dat de lijst niet volledig is.

2.7.3 Analyse van het BIPT en conclusie

62. Het BIPT neemt kennis van de verbintenis van Belgacom om alle vermeldingen te verwijderen die de indruk kunnen wekken dat de lijst niet volledig is.
63. Ondanks het ontbreken van een uitdrukkelijk antwoord veronderstelt het BIPT dat Belgacom overeenkomstig de non-discriminatieverplichting de gepaste maatregelen zal instellen om te zorgen voor een Chinese Wall tussen zijn wholesale-entiteit enerzijds en zijn retailentiteit anderzijds.

2.8 BEVEILIGING OPTIONS FOR PARTIAL CIRCUITS AND BACKHAULS

2.8.1 Probleemstelling

64. Een respondent heeft vragen bij het verschil tussen de aanbiedingen "shared" en "dedicated" (architectuur, functies, toepassingsvoorwaarden) in sectie 14 van het referentieaanbod voor de NGLL-lijnen⁶.

2.8.2 Reactie(s)

65. Belgacom heeft duidelijk gemaakt dat de titel van de sectie specifiek verwijst naar de traditionele huurlijnen en dus niet van toepassing is op de NGLL-lijnen.

2.8.3 Analyse van het BIPT

66. Om alle verwarring te vermijden vraagt het BIPT aan Belgacom om in de Executive Summary van die sectie toe te voegen dat deze niet van toepassing is op de NGLL-lijnen.

2.9 TOEGANG TOT DE "MANHOLES"

67. Belgacom is van oordeel dat de marktanalyse geen datum voor verstrekking van een referentieaanbod voor dat punt oplegt, dat de complexiteit van de kwestie het heeft belet om dat aanbod in dezelfde termijnen als zijn andere voorstellen op te stellen maar dat het aan het BIPT heeft laten weten dat het aan een voorstel werkt.
68. Het BIPT is het niet eens met het standpunt van Belgacom wat de termijn betreft, maar dat punt zal apart worden behandeld door het BIPT als voorwerp van een afzonderlijk besluit betreffende het referentieaanbod, dat door Belgacom zal worden voorgesteld in het kader van het besluit van 8 augustus 2013 betreffende de analyse van de huurlijnenmarkten.

⁶ De respondent zou meer details willen hebben over de verschillende soorten van "Fiber"-verbindingen. "Wat is het verschil tussen "Shared" en "Dedicated D 1"; Belgacom spreekt van Shared Ring of Dedicated Ring. Wat is het gebruik in de oplossing Explore? Is dat een Shared of een Dedicated verbinding?" (vrij vertaald)

3 BESLUIT

69. Het BIPT is van oordeel dat het referentieaanbod BROTSoLL, gewijzigd door het addendum in verband met de huurlijnen van de nieuwe generatie (NGLL) dat voorgelegd is door Belgacom, voldoet aan het regelgevingskader en keurt dat addendum goed, zoals het opgenomen is in bijlage B, mits de volgende aanpassingen worden aangebracht:
- 69.1. Het referentieaanbod moet het gebruik van VLAN 1 toestaan in dezelfde omstandigheden als in de huidige praktijk van het aanbod Explore Wholesale, overeenkomstig het antwoord van Belgacom via e-mail van 25 april 2014.
 - 69.2. In de paragraaf "End-Customer sites" zal Belgacom preciseren dat de alternatieve operator de vrije keuze heeft van toewijzing van de site ID's, S-Tags, C-Tags onder voorbehoud van de elders gepreciseerde beperkingen.
 - 69.3. Het deel "Configuring the NGLL service with Aggregation Point and End-Customer Sites" zal verduidelijken dat de Ethernet-switches apparatuur zijn van Belgacom die integraal deel uitmaken van de dienst.
 - 69.4. Belgacom zal het addendum "Feasibility feedback and timing estimates for fiber installation" verduidelijken door daarin de twee eerste paragrafen van zijn voorstel op te nemen en door de derde te vervangen zoals gevraagd is in § 44 hierboven.
 - 69.5. Er zullen "Improved SLAs' 6d/7 15u/24 worden toegevoegd die identiek zijn aan die van het retailaanbod, zoals door Belgacom voorgesteld is in zijn antwoord op de nationale raadpleging. Belgacom zal ook de hyperlinks naar de relevante documenten vermelden of deze documenten als bijlage toevoegen aan zijn referentieaanbod.
 - 69.6. De levering van de rapporten inzake follow-up van SLA's zal worden vermeld in het referentieaanbod.
 - 69.7. De §§ 5.3 en 7.4 van het referentieaanbod zullen worden aangevuld met het feit dat Belgacom een alternatieve oplossing zal voorstellen voor elke uitfazering, overeenkomstig het besluit van 8 augustus 2013 betreffende de analyse van de huurlijnenmarkten.
 - 69.8. Belgacom zal alle vermeldingen verwijderen die de indruk kunnen wekken dat de lijst van de inlichtingen die vereist zijn bij een verzoek om aansluiting op vezel, niet volledig is.

- 69.9. Er zal worden verduidelijkt dat het deel "securisation options for partial circuits and backhaul" niet van toepassing is op de NGLL-lijnen.
- 69.10. De identificatie van de dienst zal in het gehele aanbod worden geharmoniseerd als "NGLL" of "E-Line", ter wille van de coherentie en om elke vorm van verwarring te voorkomen.
70. Belgacom moet dit besluit uitvoeren uiterlijk een maand na de publicatie ervan op de website van het BIPT, behalve wat de bepalingen betreft waarvoor dit besluit uitdrukkelijk in een andere termijn voorziet.
71. Vervolgens, zoals artikel 59, § 4, van de wet van 13 juni 2005 voorschrijft, moet het referentieaanbod BROTSoLL, zoals door Belgacom gewijzigd om zich te voegen naar dit besluit, door het BIPT worden goedgekeurd voordat het gepubliceerd wordt. Hiertoe vraagt het BIPT aan Belgacom om het referentieaanbod te bezorgen dat aangepast is op grond van de documenten goedgekeurd door dit besluit, door enkel de in dit document vereiste aanpassingen op te nemen.

4 BEROEPSMOGELIJKHEDEN

72. Overeenkomstig artikel 2, § 1, van de wet van 17 januari 2003 betreffende de rechtsmiddelen en de geschillenbehandeling naar aanleiding van de wet van 17 januari 2003 met betrekking tot het statuut van de regulator van de Belgische post- en telecommunicatiesector hebt u de mogelijkheid om tegen dit besluit beroep in te stellen bij het hof van beroep van Brussel, Poelaertplein 1, B-1000 Brussel. Het beroep wordt, op straffe van nietigheid die ambtshalve wordt uitgesproken, ingesteld door middel van een ondertekend verzoekschrift dat wordt ingediend ter griffie van het hof van beroep van Brussel binnen een termijn van zestig dagen na de kennisgeving van het besluit of bij gebreke aan een kennisgeving, na de publicatie van het besluit of bij gebreke aan een publicatie, na de kennisname van het besluit.
73. Het verzoekschrift bevat op straffe van nietigheid de vermeldingen vereist door artikel 2, § 2, van de wet van 17 januari 2003 betreffende de rechtsmiddelen en de geschillenbehandeling naar aanleiding van de wet van 17 januari 2003 met betrekking tot het statuut van de regulator van de Belgische post- en telecommunicatiesector. Indien het verzoekschrift elementen bevat die u als vertrouwelijk beschouwt, dan moet u dat uitdrukkelijk aangeven en op straffe van nietigheid, een niet-vertrouwelijke versie van dat verzoekschrift indienen. Het Instituut publiceert op zijn website het verzoekschrift dat door de griffie van het gerecht genotificeerd is. Elke belanghebbende partij kan in de zaak tussenkomen binnen dertig dagen na deze publicatie.

Charles Cuveliez
Raadslid

Axel Desmedt
Raadslid

Luc Vanfleteren
Raadslid

Jack Hamande
Voorzitter van de Raad

BIJLAGE A. VOORSTEL VAN BELGACOM VOOR EEN ADDENDUM BIJ HET REFERENTIEAANBOD BROTSOLL

BIJLAGE A. VOORSTEL VAN BELGACOM VOOR EEN ADDENDUM BIJ HET REFERENTIEAANBOD BROTSOLL



Belgacom
Reference Offer
for
Terminating Segment
of
Leased Line

BROTSoLL

General Disclaimer :

The content of this present draft offer is submitted by Belgacom under the reserve of the grounds that Belgacom has developed in the framework of the recourse introduced against the decision of BIPT of 17 January 2007 and 8 August 2013. No adverse recognition can be deduced from the communication of the present offer in said framework or in any other framework.

Valid from XX/XX/20XX

This document starts to produce effects as of xx/xx/20xx and until one subsequent Reference Offer is validly published - As from xx/xx/20xx interested Beneficiaries are in a position to make a request for the services covered by the present document.

TABLE OF CONTENTS

1.	<u>SCOPE OF THE DOCUMENT</u>	5
2.	<u>ABBREVIATIONS IN THE DOCUMENT</u>	5
3.	<u>GENERAL SITE REQUIREMENT</u>	5
4.	<u>DESCRIPTION</u>	6
5.	<u>PARTIAL CIRCUIT</u>	8
5.1	<u>PARTIAL CIRCUIT – BELGACOM SITED</u>	8
5.2	<u>PARTIAL CIRCUIT – CUSTOMER SITED</u>	9
5.2.1	<i>NETWORK INTERFACE PARTIAL CIRCUIT CUSTOMER SITED</i>	10
5.2.2	<i>OTHER BANWDITH REQUIREMENTS</i>	10
5.3	<u>OFFER VALIDITY</u> :	10
5.4	<u>PARTIAL CIRCUIT PRICING PRINCIPLES</u>	10
6.	<u>BACKHAUL CONNECTION</u>	12
6.1	<u>THE “COLO TO COLO” LINK</u>	12
6.2	<u>THE “COLO TO POP” LINK</u>	12
6.3	<u>NETWORK INTERFACE</u>	13
6.4	<u>SIGNAL</u>	13
6.5	<u>PREREQUISITE</u>	13
6.6	<u>OTHER BANWDITH REQUIREMENTS</u>	13
7.	<u>NEXT GENERATION LEASED LINES (NGLL)</u>	14
7.1	<i>NGLL SERVICE</i>	14
7.2	<i>SERVIE AND BANDWIDTH AVAILABLE</i>	15
7.3	<i>AGGREGATION POINT AND END-CUSTOMER POINT</i>	16
7.4	<i>OFFER VALIDITY</i>	16
8.	<u>INTERNAL CABLING FOR COLO ENDING SERVICES</u>	16
9.	<u>IMPLEMENTATION</u>	16
10.	<u>CONNECTION</u>	16
11.	<u>TARIFF STRUCTURE</u>	17
11.1	<u>COLOCATION COSTS</u>	17
11.2	<u>LINK COSTS</u>	17
11.3	<u>COST OF INTERNAL CABLING</u>	17
12.	<u>SERVICE LEVEL GUARANTEE PARTIAL CIRCUITS AND BACKHAULS</u>	18
12.1	<u>SCOPE</u>	18
12.1.1	<u>SCOPE OF THE SLA</u>	18
12.1.2	<u>CONTACT PERSONS</u>	18
12.1.3	<u>BELGACOM’S OBLIGATIONS</u>	18
12.1.4	<u>CUSTOMER’S OBLIGATIONS</u>	18
12.1.4.1	<i>GENERAL OBLIGATIONS</i>	18
12.1.4.2	<i>SITE ACCESS</i>	18

12.1.4.3	COOPERATION WITH THIRD PARTIES	19
12.1.4.4	INTEGRITY OF EQUIPMENT	19
12.1.5	FORCE MAJEURE	19
12.2	PROVISIONING SERVICES	19
12.2.1	<u>DEFINITIONS RELATING TO THE INSTALLATION OF THE BELGACOM SERVICE CIRCUITS FOR THIS PROJECT.</u>	19
12.2.2	<u>PROVISIONING PROCEDURE</u>.....	20
12.2.2.1	INITIATING THE PROVISIONING PROCEDURE	20
12.2.2.2	FEEDBACK TO OPERATOR.....	20
12.2.2.3	CIRCUIT INSTALLATION	21
12.2.2.4	CLOSING OF THE ORDER	21
12.2.3	<u>BELGACOM'S OBLIGATIONS</u>.....	21
12.2.3.1	GUARANTEED FEEDBACK	21
12.2.3.2	GUARANTEED COMPLIANCE WITH THE RFS DATE	23
12.2.3.3	GUARANTEED PROVISIONING TIME.....	23
12.2.4	<u>CUSTOMER'S OBLIGATIONS</u>.....	23
12.2.4.1	SENDING THE COMPLETED ORDER FORM	23
12.2.4.2	PROVISION OF THE NECESSARY SPACE.....	24
12.2.4.3	ELECTRICAL AND PHYSICAL ENVIRONMENT	24
12.3	<u>REPAIR SERVICES</u>.....	24
12.3.1	<u>DEFINITIONS RELATED TO THE REPAIR OF THE SERVICE CIRCUITS</u>	24
12.3.1.1	DEFINITION OF CIRCUIT REPAIR TERMINOLOGY	24
12.3.1.2	CONTACT NUMBERS FOR REPORTING A SERVICE DISRUPTION	25
12.3.1.3	TYPE OF SERVICE DISRUPTION & STOP-CLOCKS	25
12.3.2	<u>REPAIR PROCEDURE</u>	26
12.3.2.1	LAUNCHING REPAIR OPERATIONS	26
12.3.2.2	FEEDBACK TO OPERATOR.....	26
12.3.2.3	REPAIR OPERATIONS.....	27
12.3.2.4	CLOSING OF THE SERVICE DISRUPTION.....	27
12.3.3	<u>BELGACOM'S OBLIGATIONS</u>.....	27
12.3.3.1	GUARANTEED FEEDBACK.....	27
12.3.3.2	GUARANTEED REPAIR TIME	28
12.3.4	<u>CUSTOMER'S OBLIGATIONS</u>.....	28
12.3.4.1	CONTACT PERSON.....	28
12.3.4.2	DETERIORATION OF SERVICE QUALITY	28
12.4	<u>MAINTENANCE</u>	29
12.4.1	<u>DEFINITIONS RELATED TO THE MAINTENANCE OF THE SERVICE CIRCUITS</u>.....	29
12.4.2	<u>MAINTENANCE PROCEDURE</u>.....	29
12.4.2.1	PROACTIVE MAINTENANCE	29
12.4.2.2	MAINTENANCE WORK PLANNED ON OPERATOR'S SITE	29
12.4.3	<u>BELGACOM'S OBLIGATIONS</u>.....	30
12.5	<u>COMPENSATION</u>	30
12.5.1	<u>PROVISIONING</u>.....	30
12.5.2	<u>REPAIRS</u>.....	30

12.5.3	<u>AVAILABILITY</u>	31
13.	SERVICE LEVEL GUARANTEE NGLL	32
13.1	SERVICE LEVEL PARAMETERS	32
13.2	INCIDENT MANAGEMENT	32
13.3	FEEDBACK TO OLO	33
13.4	SERVICE TESTORATION TIME CALCULATION	33
13.5	HOW TO CALCULATE THE SITE AVAILABILITY	33
13.6	SLA PENALTIE.....	34
13.7	E-TROUBLESHOOTING	35
14.	<u>SECURISATION OPTION PARTIAL CIRCUITS AND BACKHAULS</u>	35
14.1	<u>EXECUTIVE SUMMARY</u>	35
14.2	<u>STANDARD EQUIPMENT</u>	35
14.3	<u>SECURISATION PACKAGE</u>	37
14.4	<u>SECURISATION SERVICES</u>	38
14.5	<u>PACKAGE PRICING</u>	38
14.6	<u>SECURISATION OPTIONS</u>	41
	<u>APPENDIX 1 : LIST OF THE AREA ACCESS</u>	43

1. Scope of the document

The purpose of this document is to define the Belgacom Reference Offer for Terminating Segment of Leased Line (BROTSoLL).

To be eligible, a Terminating Segment of Leased Line must connect two "sites" being in the same Access Area. They are defined in the Annex 1. A link between two different Access Area is not concerned by this offer.

2. Abbreviations in the document

BGC :	Belgacom
PoP :	Point of Presence
Colo :	Colocation as defined in the BRUO
NGLL:	Next Generation Leased Lines
OAP:	OLO Aggregation Point
APAL:	Aggregation Point Access Line
SR:	Belgacom Service POPCPE: Customer Premises Equipment

3. General Site requirement

In order to order a service as described hereafter, all end points of any services located outside a Belgacom building have to follow and comply with the Site requirement as described in the annex hereafter.

4. Description

The present offer will regroup different type of Terminating Segment of Leased Line services.

Those services are called :

4.1 Partial Circuit and Backhaul

Partial Circuit

Partial circuit can be only ordered to connect any location except Colo to the Operator network.

- Belgacom Sited
- Customer Sited (covers Po2PoP)

Backhaul connection

- Colo2Colo
- Colo2PoP
- BROBA/BRIO handover point 2PoP

Backhaul connection can be ordered to connect Belgacom location where the Operator is subscribing to the following services :

- o Belgacom Colocation Services
- o Belgacom Reference Interconnect Offer
- o Belgacom Reference Unbundling Offer
- o Belgacom Reference Offer Bitsream Access

Both products and are using different interfaces and bandwidths as described in the section hereafter.

All those connections are point to point, permanent and transparent connectivity services.

4.2 NGLL connection

NGLL can be ordered to connect Operator network to any location.

- OLO Aggregation Point
 - o Belgacom-sited (Colo)
 - o Customer-sited (POP)
- End-customer site
 - o Customer-sited (POP/end-user)



All those connections are MPLS based services.

5. Partial Circuit

The Terminating Segment of Leased Line service enables the establishment of Leased Lines between two termination points of which at least one is located in the Belgacom Network. Therefore, Belgacom provides one or two Partial Circuit(s). Each Partial Circuit includes one of the termination points of the Leased Line and is linked to the Operator's Network at a Demarcation Point. For the sake of clarity it is noted that the Operator remains responsible towards its customers for the provision of Leased Lines involving one or two Belgacom Partial Circuit.

Two cases are possible as far as the location of the Demarcation Point related to a Partial Circuit is concerned: inside a technical building of the Operator or inside a Belgacom technical building. In the former case, the Partial Circuits are called Customer-sited Partial Circuits, in the latter case, they are called Belgacom-sited Partial Circuits.

The housing of a Demarcation Point in the context of the Terminating Segment of Leased Line service is available at all Belgacom buildings housing Area Access Points and at all Belgacom Local Exchange buildings, unless in case of technical unfeasibility which will be duly justified by Belgacom to the BIPT. The length of a Partial Circuit is defined as the straight line distance between the Belgacom local distribution frame of the Local Exchange area where the Demarcation Point is located and the Belgacom local distribution frame at which the Belgacom end-user termination point is directly connected.

In case the Demarcation Point related to a Partial Circuit is located outside a Belgacom building and subject to the conditions mentioned hereafter, Belgacom can in principle provide the Partial Circuit in the same way as it provides a Belgacom Leased Line. The conditions which are applicable to Leased Lines related to the move of one of the end-points and to the upgrade or downgrade of the Leased Line, are also applicable to Partial Circuits, provided that from the viewpoint of the operational processes the Belgacom-"end-user" relationship existing in the Leased Line service is replaced by the Belgacom-Operator relationship in the Terminating Segment of Leased Line service. Belgacom will not interact with the customer of the Operator. Subject to the same conditions, the basic SLA for Leased Lines, available on Internet, will be applicable.

5.1 Partial Circuit – Belgacom sited

The Terminating Segment of Leased Line service allows the establishment of permanent Leased Lines with a bit rate of 64 kbit/s, n*64 kbit/s (n=2, 4, 6, 8, 10), 2 Mbit/s and 34 Mbit/s. The interfaces offered at the end-user sites are:

- for 64 kbit/s Partial Circuits: V.35, V.36/V.11, X.21 (X.24/X.27), G.703 (64 kbit/s) codir
- for n*64 kbit/s Partial Circuits: V.35, V.36/V.11, X.21 (X.24/X.27), G.703/G.704 (FE1)
- for 2 Mbit/s and 34 Mbit/s Partial Circuits: G.703 electrical
- for STM-1 (VC4) Mbit/s Partial Circuits : G 655/G.707

The same interfaces are offered at the Demarcation Point, except for Belgacom-sited 64 kbit/s and n*64 kbit/s Partial Circuits for which only a G.703/G.704 2048 kbit/s is offered.

Fractional E1, Multi Fractional E1 are also available to terminate any n*64 connection.

Fractional STM-1 to terminate n*64 kb/s, E1s, E3 is also available but is subject to feasibility study and only available in the Belgacom LEX or AGE.

In case of Partial Circuit Customer sited, Interconnect Service Transport offers also Ethernet bandwidth at following speed : Fast Ethernet (100M), Gigabit Ethernet (1 Gbps).

Network interface Partial Circuit Belgacom sited

Signal	Interface	Local access
N*64 Kbps	X21,V35 or G703/704	
2 Mbps	G 703/704	Coax
34 Mbps	G 703/704	Coax
155 Mbps	G 655 - SC - 1310 nm SM	Optical fiber
Ethernet	RJ 45 - Cat 5	Twisted Pair - maximum length of the channel link is limited to 100m
Fast Ethernet	RJ 45 - Cat 5	Twisted Pair - maximum length of the channel link is limited to 100m
Gigabit Ethernet	SC - 1310 nm SM	Optical fiber

5.2 Partial Circuit – Customer sited

The Terminating Segment of Leased Line service allows the establishment of permanent Leased Lines with a bit rate of 64 kbit/s, n*64 kbit/s (n=2, 4, 6, 8, 10), 2 Mbit/s and 34 Mbit/s. The interfaces offered at the end-user sites are:

- for 64 kbit/s Partial Circuits: V.35, V.36/V.11, X.21 (X.24/X.27), G.703 (64 kbit/s) codir
- for n*64 kbit/s Partial Circuits: V.35, V.36/V.11, X.21 (X.24/X.27), G.703/G.704 (FE1)
- for 2 Mbit/s and 34 Mbit/s Partial Circuits: G.703 electrical
- for STM-1 (VC4) Mbit/s Partial Circuits : G 655/G.707

The interfaces are offered at both Demarcation Points (End customer location and Point of Presence of the Operator).

Fractional E1, Multi Fractional E1 are also available to terminate any n*64 connection.

Fractional STM-1 to terminate n*64 kb/s, E1s, E3 is also available but is subject to feasibility study and only available in the Point of Presence of the Operator.

In case of Partial Circuit Customer sited, Interconnect Service Transport offers also Ethernet bandwidth at following speed : Ethernet (10M), Fast Ethernet (100M), Gigabit Ethernet (1 Gbps).

5.2.1 Network interface Partial Circuit Customer sited

Signal	Interface	Local access
N*64 Kbps	X21,V35 or G703/704	
2 Mbps	G 703/704	Coax
34 Mbps	G 703/704	Coax
155 Mbps	G 655 - SC - 1310 nm SM	Optical fiber
Ethernet	RJ 45 – Cat 5	Twisted Pair
Fast Ethernet	RJ 45 – Cat 5	Twisted Pair
Gigabit Ethernet	SC - 1310 nm SM	Optical fiber

5.2.2 Other bandwidth requirements

Operator may require other bandwidth for the partial circuit. However, if for any specific and well-defined reason, the provision of a service governed by these terms and conditions is technically difficult to implement or to Belgacom's economic disadvantage, Belgacom reserves the right not to provide the service, or to provide it under conditions and/or at a rate that departs from these terms and conditions and/or the rates in effect.

5.3 **Offer validity :**

The attention is drawn to the fact that Belgacom may withdraw one or more parts of its Partial Circuit offer, subject to a 1 year advance notice period, in case Belgacom at the same time ends the offering of the corresponding retail leased line offer.

5.4 **Partial Circuit Pricing Principles**

The prices for the Terminating Segment of Leased Line service are indicated in the CPL here under. The prices for Belgacom-sited Partial Circuits are only applicable in case the Demarcation Point is located in buildings allowing Collocation¹, Belgacom will provide to the Operator at its request all the information needed to allow the Operator to perform the Partial Circuit price calculations by itself. The prices for Belgacom-sited Partial Circuits have to be combined with the prices associated with the collocation of the Operator's transmission equipment inside the Belgacom building. These prices are to be established on the same basis as the principles applicable to Belgacom-sited Interconnect Links. All the principles and conditions applicable to the installation and operation of Belgacom-sited Interconnect Links are also applicable to Belgacom-sited Partial Circuits. The technical, planning and operational conditions applicable to the Terminating Segment of Leased Line service are, where relevant, to be included in the Interconnect Agreement.

A Partial Circuit is put at the disposal of the Operator for a fixed initial contract period of one year. At the end of this period, the contract is tacitly renewed for an unlimited period of time. The one-year term starts on the day following the date on which the Partial Circuit is put at the disposal of the Operator. The Operator can terminate the contract at any moment, provided that the requested termination date (i.e. the date at which the

¹ Main Body : Physical Collocation pt 9; Distant Collocation pt 8 and Co-mingling pt 12



contract for the Partial Circuit concerned will be terminated and the Partial Circuit concerned will be taken out of service) is at least 15 calendar days later than the day following the receipt of the notification of the cancellation. If the termination date is before the end of the initial one-year contract period, a cancellation fee corresponding to the rental fee for the cancelled Partial Circuit for the period between the termination date and the end of the initial contract period will have to be paid by the Operator.

If Operator is ordering more than 25 partial circuits per month, specific forecast process will have to be put in place between the Operator and Belgacom. Belgacom will be entitled to charge to the Operator specific project fee to coordinate installation and provisioning of the different partial circuits ordered by the Operator.

6. Backhaul Connection

6.1 The "Colo to Colo" link

The "Colo to Colo" link service enables the establishment of a service ending on one end in the colocation area of the operator and on the other end in another colocation area of the operator, in two different Belgacom buildings.

The Colocation of the operator may be sited in a LEX or in an AGE.

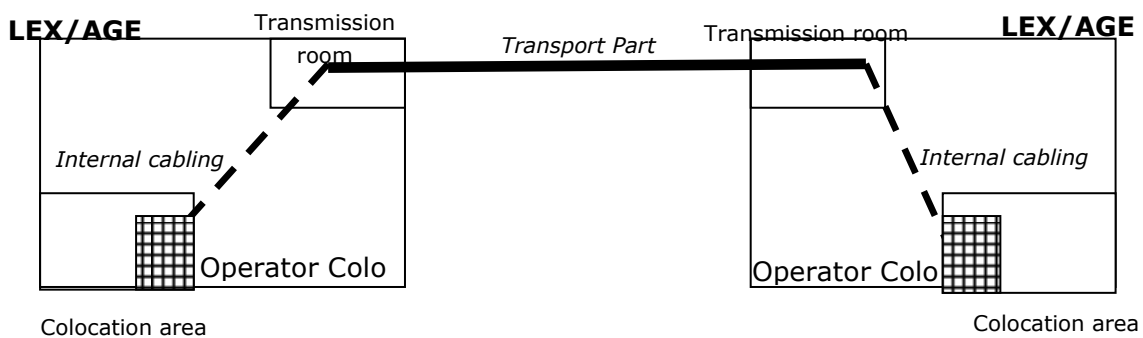

Service & Bandwidth Available for Colo to Colo

Leased Lines Type Services

At following speed : 2 Mbps, 34 Mbps, STM-1 (155 Mbps)

Ethernet Type Services

At following speed : Fast & Gigabit Ethernet.

6.2 The "Colo to PoP" link

The "Colo to PoP" link service enables the establishment of a service ending on one end in the colocation area of Operator, on the other end on a Point of Presence (PoP) of the operator.

The Colocation of the operator may be sited in a LEX or in an AGE.

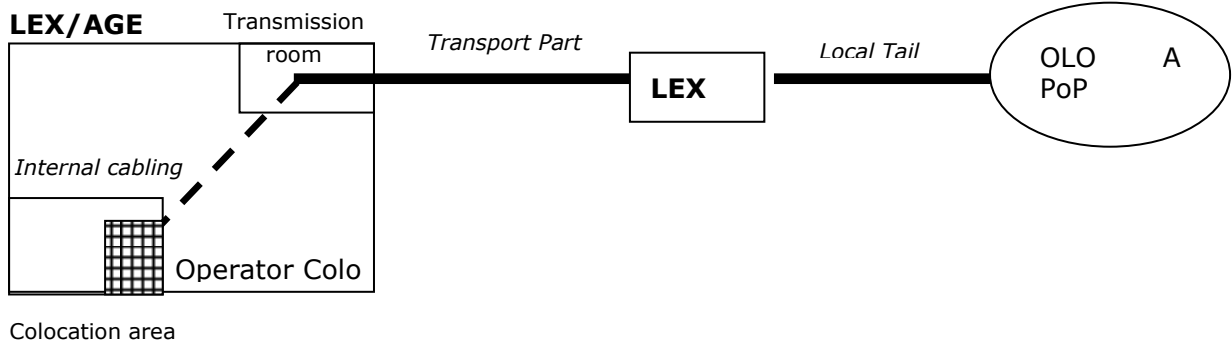

Service & Bandwidth Available for Colo to Colo

Leased Lines Type Services

At following speed : 2 Mbps, 34 Mbps, STM-1 (155 Mbps)

Ethernet Type Services

At following speed : Fast & Gigabit Ethernet

6.3 Network interface

Signal	Interface	Local access
2 Mbps	G 703/704	Coax
34 Mbps	G 703/704	Coax
155 Mbps	G 655 - SC - 1310 nm SM	Optical fiber
Fast Ethernet	RJ 45 - Cat 5	Twisted Pair
Gigabit Ethernet	SC - 1310 nm SM	Optical fiber

6.4 Signal

2,34,155 follow ITU-T Standardiation G 703/704, G 707, G 655

Gigabit Ethernet Standard: IEEE 802.3z full duplex (1000Base-LX)

6.5 Prerequisite

Colocation is a prerequisite for ordering the present Service.

The specific conditions for Colocation can be found in the frame of the BRUO, more particularly the General Terms and Conditions for Colocation, as these are available on the Belgacom Website.

6.6 Other bandwidth requirements

Operator may require other bandwidth for the partial circuit. However, if for any specific and well-defined reason, the provision of a service governed by these terms and conditions is technically difficult to implement or to Belgacom's economic disadvantage, Belgacom reserves the right not to provide the service, or to provide it under conditions and/or at a rate that departs from these terms and conditions and/or the rates in effect.

7. Next Generation Leased Lines (NGLL)

7.1 NGLL Service

NGLL is an Ethernet (Layer2) connectivity service; it is based on Ethernet over MPLS technology and can be accessed via Ethernet over copper (Ethernet in the First Mile = EFM) or Ethernet over fiber.

End-Customer sites

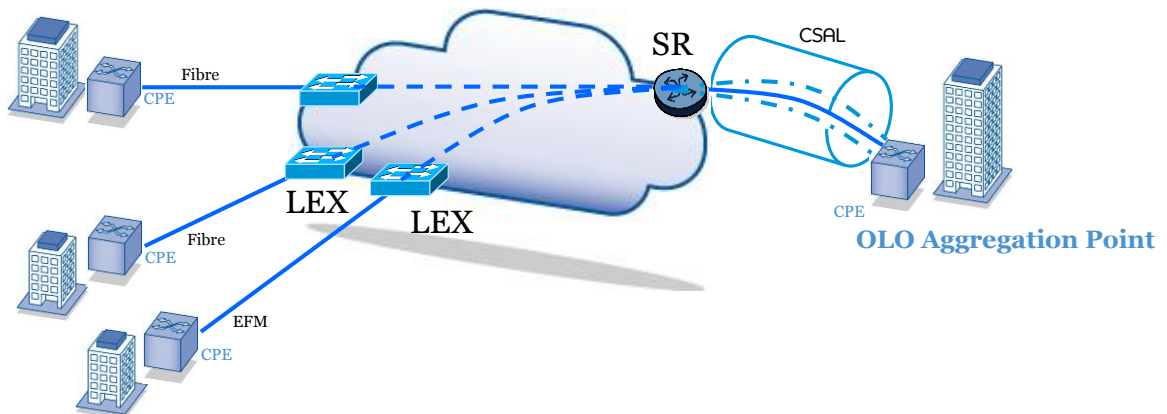

Per Area there are 2 Service Pops(SR). The OLO Aggregation Point (OAP) is connected to the Service POP of an Ethane AREA (not to a LEX).

End-user sites will be connected to the LEXs of one or more ETHANE AREAs.

NGLL : a NGLL is connecting **one** end-user site to **one** OLO Aggregation Point, **both located** in the same ETHANE AREA.

Therefore, an OLO having one or more end-user sites in a given Area must have an OLO Aggregation Point connected to at least one of two service POPs of this Area.

An OLO having end-users in more than one Ethane Area, must have also more than one OLO Aggregation Point.

Within the NGLL solution, traffic will always flow between a End-Customer site and OLO Aggregation Point.

Never between End-Customer Site and End-Customer Site (no any-to-any functionality).

The OLO Aggregation Point can be : always Belgacom Service POP

- An OLO POP
- A colocation

The end-customer site can be: always LEX

- An OLO POP
- An end-user site

Belgacom will propose the access technology Ethernet over copper (EFM) and fiber-based Ethernet, fast Ethernet and Gigabit Ethernet.

7.2 Service and Bandwidth available

OLO Aggregation Point:

<u>Bandwidth</u>	<u>Access</u>
100Mbps	Fiber
200Mbps	Fiber
300Mbps	Fiber
400Mbps	Fiber
500Mbps	Fiber
600Mbps	Fiber
700Mbps	Fiber
800Mbps	Fiber
900Mbps	Fiber
1Gbps	Fiber

End-Customer site:

<u>Bandwidth</u>	<u>Access</u>
2Mbps	Copper or Fiber
4Mbps	Copper or Fiber
6Mbps	Copper or Fiber
8Mbps	Copper or Fiber
10Mbps	Copper or Fiber
20Mbps	Copper or Fiber
30Mbps	Fiber
40Mbps	Fiber
50Mbps	Fiber
60Mbps	Fiber
70Mbps	Fiber
80Mbps	Fiber
90Mbps	Fiber
100Mbps	Fiber
200Mbps	Fiber
300Mbps	Fiber
400Mbps	Fiber
500Mbps	Fiber
600Mbps	Fiber
700Mbps	Fiber
800Mbps	Fiber
900Mbps	Fiber

1Gbps	Fiber
-------	-------

7.3 OLO Aggregation point and End-customer point

A start configuration consists of an OLO Aggregation Point and one or more End-Customer Sites.

OLO Aggregation Point (OAP):

The OLO Aggregation Point is connected using a Gigabit Ethernet access line, called Aggregation Point Access Line (APAL).

The traffic of all Remote Sites will be delivered on the OLO Aggregation Point Access Line.

End-Customer site:

The End-Customer Sites can be connected via Ethernet over copper (EFM) or Ethernet over fiber.

7.4 Offer validity

The attention is drawn to the fact that Belgacom may withdraw one or more parts of its NGLL offer, subject to a 1 year advance notice period, in case Belgacom at the same time ends the offering of the corresponding retail service.

8. **Internal cabling for Colo Ending Services**

Belgacom delivers a full end-to-end Service, including the internal cabling from Colocation to the Belgacom Transmission room. For avoidance of doubt, Belgacom will deliver the internal cabling on the infrastructure that is the most appropriate without reference to any other applications. Nonetheless, pricing of internal cabling will be charge separately from the charge of service itself.

In the BRIO handover this connection is limited to 2 Mbps and in BROBA handover, the following bandwidths are accepted : 2 Mbps, 34 Mbps & 155 Mbps.

9. **Implementation**

The implementation will be made in accordance with the technical specifications as defined in documents present at the following website :

http://www.belgacom.com/group/eu-en/annex/An_Network_specs.page

10. **Connection**

10.1 Partial Circuit and Backhaul

In case of any Colo Link services, the Network Termination Point (NTP) is located at the end of the indoor cable provided by Belgacom and connecting the Operator's transmission equipment to the Belgacom Access Point, at the Operator side (including the attached connector if this connector has been delivered and fixed by Belgacom).

The connection of the cable to the equipment of the operator is outside the responsibility of Belgacom.

10.2 NGLL

The termination point of the NGLL is the Gigabit interface of the Belgacom CPE switch.

11. Tariff structure

11.1 Colocation costs

Operator shall pay Belgacom the applicable costs for Colocation as specified in the relevant General Terms and Conditions for Colocation.

11.2 Link costs

For each circuit, the costs for the Access to the Service are charged both at the RFS date and further on on a monthly basis.

Installation costs at installation are charged per circuit.

Belgacom will not be charged any cost nor will Belgacom pay any fee for the installation of Belgacom equipment in Operator's building.

11.3 Cost of Internal cabling

The cost of internal cabling between Operator's colocation and the Belgacom Transmission room is not included in the tariffs further specified.

12. Service Level Guarantee Partial Circuits and Backhauls

12.1 SCOPE

12.1.1 SCOPE OF THE SLA

This Service Level Agreement sets out the terms and conditions under which Belgacom will provide installation, maintenance and repair services for the Belgacom Service. If Belgacom announces better service levels for Service than those described in this agreement, Operator will be informed and may request to benefit from them.

This SLA shall apply from the date of the installation of the circuit for the term specified in the Order Form signed by Operator.

Internal cabling is excluded from any SLA.

12.1.2 CONTACT PERSONS

For any questions regarding Terminating Segment of Leased Line Service, Operator may:

- consult Belgacom's Internet site at <http://www.belgacom.be/>
- contact the Account Manager;
- contact the Account Administrator of Belgacom's Customer Service department;

12.1.3 BELGACOM'S OBLIGATIONS

Belgacom will deliver the Service in accordance with the conditions herein described. The data registered in Belgacom's operational database will serve as sole proof of Belgacom's fulfilment of its obligations.

12.1.4 CUSTOMER'S OBLIGATIONS

12.1.4.1 General obligations

Considering that Operator's colocation will be available in the relevant sites, Operator will order a circuit in accordance with the provisioning process described here-under.

12.1.4.2 Site Access

Operator shall provide Belgacom's technicians with access to the site for provisioning, repair and maintenance. If necessary, Operator shall take all necessary steps to ensure full cooperation of the owner of the site(s.)

12.1.4.3 Cooperation with Third Parties

Operator shall ensure that any sub-contractors managing any part of Operator's network cooperate with Belgacom. Belgacom shall not be liable for any problems whatsoever attributable to third-party involvement.

12.1.4.4 Integrity of equipment

Operator shall be responsible for the integrity of any equipment installed by Belgacom on Operator's premises.

12.1.5 FORCE MAJEURE

Failure to comply or omission by one party under the terms or conditions of this SLA shall not constitute grounds for a claim by the other party against the former for damages or compensation, nor shall it be deemed to be a breach of obligations insofar as it is attributable to force majeure as defined in the General Terms & Conditions.

12.2 PROVISIONING SERVICES

12.2.1 DEFINITIONS RELATING TO THE INSTALLATION OF THE BELGACOM SERVICE CIRCUITS FOR THIS PROJECT.

Order Form:	Standard form used to order the SERVICE circuits offered by Belgacom, and which is an integral part of the Agreement.
RFS Date:	Ready For Service date, i.e., the date on which the circuit is ready for use and billed.
Order Registration	Entry in Belgacom's computer system of the order for the provision by Belgacom operators of the services on the circuit.
Order Registration Time:	Time elapsing between the date on which the duly completed and signed Order Form is submitted to Belgacom and the date the order is registered.
Provisioning Time:	Time elapsing between the registration of the order and the RFS date agreed by Belgacom.
RFB:	Ready For Belgacom. A Customer site is RFB once Operator has installed, on private premises, the infrastructure (i.e., cables, electrical and physical environment, space required for the equipment) necessary for the service to be provided to the telecommunications site indicated by Operator and once Operator has confirmed this to Belgacom or has appointed Belgacom to carry out the infrastructure work on the premises.
CRD:	Customer Request Date, i.e., the date requested by Operator for the delivery of the service, as specified on the Order Form.

EMC:	Electromagnetic Compliance.
Property survey:	Survey conducted by Belgacom representatives in the areas surrounding the Sites for the purpose of implementing a connection between Operator's Site and Belgacom's network.
Site Survey:	Visit of site(s) by Belgacom representatives for the purpose of assessing the work required to install the NTE (Network Connectivity Equipment) for the provision of the OMDF interconnection and, in general, of the Service requested by Operator.

12.2.2 PROVISIONING PROCEDURE

12.2.2.1 Initiating the provisioning procedure

Filling in the Order Form

Operator shall use a SERVICE order form to order the services.

- For both end sites, Operator must specify the precise location where the Service is to be delivered and, if possible, the type of work to be carried out on the private premises. If a SERVICE circuit is supplied to a site or telecommunications room that does not belong to Operator, Operator ordering the service shall be responsible for obtaining correct and complete information about the site or the telecommunications room from the third party and provide this to Belgacom.
- The duly completed and signed order form shall be sent to Belgacom:
 - o via the Account Administrator;
 - o via Operator's Account Manager.

Order Registration

The duly completed and signed order form is entered in Belgacom's computer systems on receipt so that Belgacom can proceed to provide the Service. This operation is generally performed within one working day of receipt of the order provided that the order form is properly completed. In other cases, Belgacom will contact Operator, so that the Order Form can, if possible, be completed.

The lead time for the provision of the service shall start on the date on which the correctly filled in order is entered in the Belgacom operational database.

12.2.2.2 Feedback to Operator

- Order Confirmation

Once the completed order form has been entered in its computer systems, Belgacom shall confirm receipt of the order form to Operator, along with the code numbers for the new circuit(s), by e-mail or fax. This generally takes place on the same day as the registration of the order. The guaranteed maximum confirmation time is specified in Point 12.2.3.1.

If possible, Belgacom will provide Operator with the planned circuit RFS date at the same time. Insofar as possible, the planned RFS date will reflect the CRD and the maximum provisioning time.
- Change to the planned RFS date

In principle, no change will be made to the planned RFS date confirmed to Operator once the order has been registered. Nevertheless, if additional actions are still necessary, Belgacom shall inform Operator of the status of the order and the reason for the delay within the timeframe specified. If possible, Belgacom will provide the new planned RFS date at the same time.

The planned RFS date may be changed in the following situations:

- o Operator has been unable to agree on a date for the site survey(s);
 - o Operator has asked to postpone the site survey(s);
 - o Operator has been unable to attend the site survey(s).
 - o The site survey(s) has been completed, but Operator has not been able to confirm the site(s) RFB;
 - o Cable work on the public or private property for which Belgacom needs a work permit must be carried out.
- The following situations can also result in a change in the planned RFS date and prevent Belgacom from setting an RFS date within the guaranteed deadline for additional feedback:
 - o Operator confirms that a site is RFB, but this is not actually the case;
 - o A site survey has been carried out and Operator has confirmed the site RFB, but only after the agreed date for additional feedback;
 - o Belgacom technicians have not been granted access to Operator' site.

12.2.2.3 Circuit Installation

- SERVICE infrastructure in place
If the SERVICE infrastructure is in place at each site and no other cabling work is required, the circuit can be provided directly.
- SERVICE Infrastructure not in place
If the SERVICE infrastructure is unavailable on one of the sites, the SERVICE circuit shall not be provided until the required infrastructure has been installed.
- SERVICE Equipment
If the SERVICE infrastructure is available, Belgacom can install the SERVICE equipment (i.e., the racks to hold the chassis, the chassis themselves, the OMDF and the cabling between the OMDF and the chassis, as well as any other equipment that is necessary to provide the Service, as defined in the Order Form.

12.2.2.4 Closing of the order

Once the order is closed, Belgacom will inform Operator by fax or e-mail that the circuit can be used and will be billed.

12.2.3 **BELGACOM'S OBLIGATIONS**

The following SLA timers do not cover the BROTSoLL lines finishing on BRIO handover point. To find it, please find the reference into the P&O of the BRIO offer.

12.2.3.1 Guaranteed Feedback

	Initial Feedback
Circuits	2 WD

Table 1: Guaranteed Feedback

This time is calculated from the date on which the duly completed order form is received. Additional feedback will also be provided if the initial schedule must be revised.

12.2.3.2 Guaranteed Compliance with the RFS Date

Belgacom shall comply with the planned RFS date, of which the Operator shall be notified when the order is registered.

Compliance with RFS Date
100%

Table 2: Guaranteed Compliance with the RFS Date

The RFS date shall not be binding where the provision of the circuit is delayed for reasons attributable to the Operator, such as the postponement or cancellation of a site survey by Operator, failure by the Operator to comply with Belgacom's technical specifications,, etc.

12.2.3.3 Guaranteed provisioning time

Where the Infrastructure is in place, Belgacom shall give an undertaking that the overall Provisioning Time for the Terminating Segment of Leased Lines shall not exceed the values given in the table below, except where the delay is at the Operator's request or mutual agreement has been reached on the timing of the project.

	64 - 128 kbps, n x 64 kbps	n x 64 kbps, 2 Mbps	34 Mbps	155 Mbps
Digital national LLs	10 WD	15 WD	30 WD	Project Based
BCS Dual-Ended				
High	10 WD			Project Based
End-to-End	10 WD			Project Based

Table 3: Guaranteed provisioning time

* If the Operator explicitly requests a new Syrar multiplexer, the standard provisioning time for 64 Kbps and 128 Kbps lines shall be 15 working days.

It should be noted that the standard Provisioning Time cannot be guaranteed for 140 Mbps leased lines due to the level of capacity concerned.

N.B.: For upgrades on an existing structure and line relocations, the standard provisioning time given in the table above shall be the time necessary for Belgacom to be ready to perform the physical upgrade or relocation. The precise time of the physical operation is mutually agreed with the Operator.

12.2.4 CUSTOMER'S OBLIGATIONS

12.2.4.1 Sending the completed order form

Operator shall provide Belgacom with the information specified in the order form.

12.2.4.2 Provision of the necessary space

Operator shall make sufficient space available in the telecommunications room for Belgacom to install the equipment and the entire infrastructure necessary to implement the circuit. If necessary, Operator shall obtain the consent of the owner of this telecommunications room.

12.2.4.3 Electrical and physical environment

- Electric power supply
If Belgacom's equipment is installed directly in the Operator's telecommunications room, the latter shall guarantee access to a power outlet that complies with Belgacom's requirements and that enables the connection equipment to operate properly. Operator shall also provide Belgacom with an isolating grounding rod connected to the building's grounding terminal, in compliance with Belgacom's requirements.
- Physical environment
If Belgacom's equipment is installed directly in the Operator's telecommunications room, Operator shall ensure that the physical conditions in the room comply with Belgacom's requirements, if necessary, regarding EMC, temperature, relative humidity, the ventilation system and safety regulations.

12.3 REPAIR SERVICES

12.3.1 DEFINITIONS RELATED TO THE REPAIR OF THE SERVICE CIRCUITS

12.3.1.1 Definition of circuit repair terminology

Trouble Ticket:	File created by front-end helpdesk operator in Belgacom's IT system when Operator reports a problem. This file contains the information already available in the legacy systems, the information provided by Operator and the information added by technicians during the repair process.
Trouble Intake:	Creation of the Trouble Ticket in the IT systems for the restoration of Belgacom's services.
Total Repair Time:	Time needed to restore the service for Operator. The time is calculated between the Trouble Intake and the technical closing of the Trouble Ticket, i.e., the moment the service is operational again.
Stop-Clock Time:	Time lost during repair activities due to causes beyond Belgacom's control, e.g., inability to access certain sites, delayed actions by third parties carrying out work before Belgacom, required line measurements, etc.
Net Repair Time:	Difference between the Total Repair Time and the Stop-Clock Time.
Time before First Action:	Interval between the Operator's report of the disruption and the first action taken by a Belgacom technician to restore this disruption, either via a remote or on-site operation.

Clock Hours: Target Repair Time expressed in Clock Hours means that the service is available 24 hours per day 7 days per week.
 NOC: Network Operations Center.

12.3.1.2 Contact numbers for reporting a service disruption

Operator may report a service disruption to the toll-free number below:

Repairs	
0800 33 100	(French)
0800 22 100	(Dutch)
0800 44 100	(German)
0800 55 100	(English)
+32 70 211 100	Outside Belgium (not toll-free)

Table 4: Contact numbers

12.3.1.3 Type of service disruption & stop-clocks

Type of service disruption

When reporting a service disruption, it is essential to clearly define the type of disruption, i.e., to distinguish between problems that have an impact on traffic and those that do not.

- Impact on traffic: A service disruption shall be deemed to have an impact on traffic when it necessitates immediate action by Belgacom in order to be restored, i.e., the case of a complete circuit failure.
- No impact on traffic: A service disruption shall be deemed not to have any impact on traffic when it does not require immediate action by Belgacom to be repaired, e.g., a recurring disruption, quality deterioration, etc.

Service disruptions that have no impact on traffic shall be reported in the same manner as those that do. However, since a solution to these problems generally requires a long-term assessment, Belgacom cannot guarantee the same repair time as it does for faults resulting in a complete circuit failure.

In case of quality deterioration and recurring disruptions, it is Operator’s obligation to decide if the problem has an impact on traffic. If this is the case, Operator shall authorize Belgacom to cut the disrupted circuit, if necessary, so that repair can begin immediately and within the agreed timeframe.

Stop-clock rules

There are three situations in which Belgacom may use a stop-clock:

- All possible (remote) tests have been conducted. Operator cannot cooperate due to a lack of staff on site, access to the site is not possible, or several attempts to contact Operator by telephone have failed (see section 12.3.4).
- Operator asks for the repair to be postponed.
- Monitoring in two cases:

- o If, when the Trouble Ticket is opened, Belgacom carries out a complete check of the circuit and does not identify any problem (no alarms, erroneous bits, clock problems; correct signal level, etc.); Operator does not want Belgacom to cut the circuit to conduct tests; Belgacom wants to be absolutely sure that there is or is not a fault in the circuit and shall monitor the circuit with Operator's approval.
- o Operator's circuit has been repaired and Operator agrees that it functions properly, but suggests that the circuit be monitored in order to fully check its stability.

If a stop-clock is used, this will be reported in detail in the system, i.e.,

- reason for stop-clock;
- action to be taken;
- timing;
- name of contact person in Operator's organization who agreed to the stop-clock (unless Operator cannot be contacted via telephone.)

12.3.2 REPAIR PROCEDURE

12.3.2.1 Launching repair operations

A service disruption may be notified either by a Customer's call or as a result of proactive internal monitoring and a routine test.

- The circuit management technology used enables proactive detection of service disruptions in SERVICE circuits. The management data is centralized in Belgacom's Network Operations Center. If necessary, Belgacom will itself launch the repair procedure, depending on how serious the problem is.
- When a service disruption is reported by phone by a Customer, the latter shall provide following information to Belgacom's Helpdesk:
 - o Allocated code: Code number of the SERVICE circuit
 - o Type of disruption: Whether or not the service disruption impacts traffic
 - o Description of the problem and possible conclusions such as:
 - "circuit out of order since..."
 - "brief failures of about ... seconds"
 - "recurring disruption"
 - "recently installed"
 - "equipment impacted"
 - o Contact for follow-up: Name, telephone and/or fax number, e-mail address of Operator/caller to be informed of the follow-up to the breakdown, during and outside working hours.
 - o Contact at Operator Sites: Name, telephone and/or fax number and access procedure for the on-site contacts in Belgium who are available to cooperate with Belgacom to repair the circuit failure, if necessary.

For each service disruption, a Trouble Ticket will be generated, and Belgacom will inform Operator of the Trouble Ticket number. This identification number shall be used by both Parties in any communication between them regarding the service disruption.

12.3.2.2 Feedback to Operator

With the agreement of Operator, Belgacom's NOC shall telephone the former regularly to inform him of the technical status, reporting details such as:

- the initial diagnosis;

- the estimated repair time (where possible);
- the impact of the service disruption;
- the on-site action required.

Initial action shall be taken within 30 minutes of notification of the disruption. The initial information shall be provided at regular intervals after the creation of the Trouble Ticket. In the case of service disruptions impacting traffic additional information shall be provided. The time is calculated as from the time the Trouble Ticket is registered in Belgacom's system.

If on-site action is required and Belgacom's technicians have not been authorized to enter the Site and therefore to carry out the operations necessary to clear the fault, Belgacom shall notify Operator. This situation shall then be Operator's responsibility, who must take the action necessary to remedy it. During this time, the repair process shall be put on hold (the stop-clock will be used) until the technicians are able to access the Site.

12.3.2.3 Repair operations

For on-site repair, specific access procedures shall be indicated at the time of the Trouble Intake.

- Internal escalation procedure
In the event of recurring problems, Belgacom's operators shall automatically brief their respective managers at specified intervals, in accordance with an internal emergency procedure. The manager concerned shall then take the measures necessary to restore the circuit as soon as possible.
- The different escalation levels are:

○ CSD Operator: Level 0	T0
○ TAC (Technical Assistance Center) Supervisor: Level 1	T0+3h
○ TAC (Technical Assistance Center) Manager: Level 2	T0+6h
○ ROC (Remote Operations Center) Director: Level 3	T0+12h

12.3.2.4 Closing of the service disruption

The Trouble Ticket may not be closed without the Operator's consent. Belgacom shall provide the following information to the Operator by telephone:

- the Trouble Ticket number;
- the time the circuit is put back into operation;
- the cause of the service disruption (if known;)
- the party (Operator, Belgacom, other) responsible for the service disruption (if known.)

If Operator requires additional time to conduct his/her own tests on the repaired circuit, a stop-clock shall be used. In the event of a disagreement, Belgacom shall conduct additional tests.

12.3.3 **BELGACOM'S OBLIGATIONS**

12.3.3.1 Guaranteed feedback

Maximum Response Time	Initial information within	Additional information within
30 min.	1 hour	To be agreed with Customer

Table 5: Feedback to Operator in case of service disruption

12.3.3.2 Guaranteed Repair Time

Disruptions impacting traffic

	Guaranteed Repair Time
64 – 128 kbps, n x 64 kbps	5 Clock Hours
2 – 34 – 155 Mbps	4 Clock Hours

Table 6: Guaranteed repair Time for disruptions impacting traffic

Disruptions not impacting traffic

	Guaranteed Repair Time
SERVICE Circuits	3 WD

Table 7: Target Repair Time for disruptions not impacting traffic

BCS Dual-Ended

	Guaranteed Repair Time
n x 64 kbps	5 Clock Hours
> 2 Mbps	3 Clock Hours

Table 8: Target Repair Time for BSC Dual-Ended

-
- All the above timeframes shall be calculated from the time of the Trouble Intake.
- Please note that the Belgacom Trouble Ticket System shall be the only reference that can be used to determine whether or not the Repair Time has been met.
- The guaranteed Repair Time shall not apply to cases of force majeure.
- The guaranteed maximum repair time shall only apply if the circuit is completely out of order (if the network connectivity equipment, the active route, and possibly the passive route, are out of order.)
- If a secure circuit (with both an active and passive route) becomes less secure (if the active route is out of order), the average time required to remedy the situation is eight hours.

12.3.4 CUSTOMER'S OBLIGATIONS

12.3.4.1 Contact person

Operator shall guarantee the availability of a Helpdesk, if possible. If Belgacom cannot contact Operator to inform him/her of the progress made in the repair process, Belgacom cannot guarantee feedback deadlines and repair times.

12.3.4.2 Deterioration of service quality

In the event of deterioration of the circuit quality, Operator shall authorize Belgacom to cut the circuit affected by the disruption in order to carry out repair measures. If Operator refuses, Belgacom shall deem the Trouble Ticket to be in stop-clock mode, since no repair operations are possible.

12.4 MAINTENANCE

12.4.1 DEFINITIONS RELATED TO THE MAINTENANCE OF THE SERVICE CIRCUITS

Circuit unavailability shall mean the amount of time in the course of the year that the circuit cannot be used because of a disruption attributable to Belgacom. Unavailability is based on the calculation of the Net Repair Time for each Trouble Ticket generated during the year, encompassing solely those Trouble Tickets for which Belgacom is responsible and which result in a complete circuit failure.

Circuit availability = 100% minus any time that the circuit is unavailable.

Work that is scheduled is not taken into account in the calculation of the availability rate.

12.4.2 MAINTENANCE PROCEDURE

12.4.2.1 Proactive maintenance

Belgacom performs maintenance operations on an ongoing basis in order to provide Operator better quality of service. Such maintenance operations include:

- repair operations that do not impact the Operator's traffic;
- changes in circuit routing for maintenance purposes;
- installation of new infrastructure within the network or on Operator's premises;

Belgacom shall inform Operator in advance of any maintenance operation required on the Operator's premises, so that the operation date can be agreed on, based on the Parties' availability.

12.4.2.2 Maintenance work planned on Operator's site

Operator shall inform Belgacom of all the maintenance work that it plans to carry out in its buildings that could affect the availability of the telecommunications services provided by Belgacom. This relates to work on electricity, internal cabling and any work carried out in the telecommunications room that could affect the availability of the telecommunications services provided by Belgacom.

Such information will make it easier to monitor any alarm signals that are displayed on Belgacom's network management platform, and will prevent Belgacom from carrying out unnecessary repair work.

Operator shall comply with the procedure set out below

For work that has been scheduled

- Notify Belgacom at the following e-mail address of the planned work five working days in advance: Planned.Works.NMC.TMON@belgacom.be
- Operator shall provide Belgacom with the following information:
 - the precise location of the planned work to be carried out;
 - the type of work planned;
 - the time and date this planned work will take place;
 - the duration of the planned work;
 - the Belgacom equipment concerned (label);
 - the contact person and his/her fixed-line or mobile telephone number.

- The TMON service shall send his Customer an acknowledgement of receipt and provide a number for the planned work (PW no.)
- Immediately before the start of the maintenance work and just after the completion, Operator shall call the TMON department at +32 2 246 98 23

Unscheduled work

- Operator shall notify Belgacom by calling: +32 2 246 98 23
- Operator shall provide Belgacom with the following information:
 - the precise location of the work to be carried out;
 - the type of work planned;
 - the time and date this planned work will take place;
 - the duration of this work;
 - the Belgacom equipment concerned (label);
 - the contact person and his/her fixed-line or mobile telephone number.

12.4.3 BELGACOM'S OBLIGATIONS

Guaranteed availability

Types	Minimum availability of the SERVICE circuit (yearly basis)
Standard Circuits	99.9%

Table 9: Minimum availability (on a yearly basis)

The availability of the services shall only be guaranteed on a yearly basis.

12.5 COMPENSATION

12.5.1 PROVISIONING

If the RFS date is not complied with for reasons attributable to Belgacom, Operator shall be entitled to the compensation specified in the table below.

The monthly subscription charge in the table is that for the SERVICE circuit:

No. of Days after RFS date	Compensation
1 - 5 WD	25% of the monthly charge
6 -10 WD	50% of the monthly charge
More than 10 WD	100% of the monthly charge

Table 10: Compensation for provisioning delays

12.5.2 REPAIRS

If the repair time for service disruptions impacting traffic is not complied with for reasons attributable to Belgacom, Operator shall be entitled to compensation, as specified in the table below. Operator shall not be entitled to compensation for disruptions for which itself or a third party is responsible. The monthly subscription charge in the table applies to the SERVICE circuits. The applicable repair time is the Net Repair Time, i.e., after stop-clock time has been deducted.

Net Repair Time	SERVICE circuits
> 5 working hours	10% of the monthly subscription charge
> 8 working hours	15% of the monthly subscription charge
> 12 working hours	20% of the monthly subscription charge
> 24 working hours	25% of the monthly subscription charge
> 48 working hours	30 % of the monthly subscription charge
> 72 working hours	35% of the monthly subscription charge

Table 11: Compensation for repair

12.5.3 AVAILABILITY

If the guaranteed minimum yearly availability of the circuit is not complied with for reasons attributable to Belgacom, Operator shall be entitled to the compensation specified in the table below. The term 'availability' is defined in Section 12.4.1.

Type	Compensation
SERVICE Circuit	10% of the yearly value of the `SERVICE circuit.

Table 12: Compensation related to the minimum availability guarantee (calculated on a yearly basis)

N.B.:

- The calculation period for the circuit availability is defined as follows: start date of the calculation period (dd/mm/yyyy) + 365 calendar days or 366 calendar days for leap years (= end date of the calculation period). The circuit must be operational on the end date of the calculation period.
- The yearly value of the circuit is calculated as follows: monthly circuit subscription charge applicable during the last month of the calculation period for circuit availability x 12.
- Calculation of availability is based on the opening of trouble tickets.

13. Service Level Guarantee NGLL

13.1 Service level parameters

Service Level Agreement (SLA) relates to the following parameters:

- Restoration of service (in the event of service disruption)
- Site availability.

Activation time limit	depending on the type of access and subject to availability study
Intervention window	10x5 (8 a.m. to 6 p.m., Monday to Friday)
Service reactivation time limit – Severity 1 incident	<= 5 hours
Annual availability	99.90%

Notes:

1. The activation time values are indicative values.

2. the installation lead time of any line needing splicing works in the public domain has increased significantly since February 2012. The installation lead time of any line without splicing works is NOT impacted by this new regulation.

In virtue of the article 192/2 of the RGIE/AREI (), and in order to insure the security of our technicians and other individuals, our technicians must consult the maps of the underground electric cables installed by any other utility company before carrying out any splicing works.*

In case of splicing works, the time needed to request and receive those maps introduces a delay in our current installation process. This delay is hardly predictable, as there is no binding and uniform duration for the utility companies to answer a plan request.

() RGIE=Règlement Général sur les Installations Electriques / AREI=Algemeen Reglement op de Elektrische Installaties.*

Table 13: Standard SLA – Service level parameters

13.2 Incident Management

An incident severity level is allocated to every reported incident. Four incident severity levels have been created to reflect the impact on the availability of an OLO site:

- Severity 1: service disrupted.
- Severity 2: deteriorated service (brief interruptions/slowness/quality problems).
- Severity 3: request for information, request for reconfiguration, etc.

In case of Severity 1 Belgacom guarantees to comply with the service reactivation time specified in the case of a Severity 1 problem and compensation can be claimed.

Should the service be unavailable due to *force majeure* (any problem falling outside the scope of Belgacom's responsibilities) or a fault by the OLO (site cannot be accessed, contact person cannot be reached, service breakdown attributable to actions performed by the OLO, application problems, etc.), the service reactivation time specified will be the target aimed for, but will not be binding.

In the case of a Severity 2 problem, the service reactivation time specified will be the target aimed for, but there is no possibility for compensation claim.

In the case of a Severity 3 problem, the target will be to resolve it within the best delay, at the latest on the following business day.

13.3 Feedback to OLO

The first feedback will be given within 15 minutes from the time of trouble ticket creation. This first feedback will provide information about the access test result and an explanation of what action(s) will be taken next to reactivate the service.

After one hour, the outcome of the first technical analysis will be reported.

You can follow the progress made and the action taken on our Internet site using our e-Troubleshooting tool.

Belgacom will inform you via e-mail when the service has been reactivated. You will be asked to confirm that the service has been reactivated. If you do not respond within 24 hours of being notified of the service reactivation, the trouble ticket will be closed.

13.4 Service restoration time calculation

The Service Restoration timeframe (the net restoration time) shall run from trouble ticket creation time until the time when the incident is definitively resolved. The following shall not be included or taken into account in the calculation of the Net Restoration Time:

- Trouble tickets relating to Service unavailability as a result of:
 - planned maintenance work (as described in the E-Line contract);
 - reasons attributable to the OLO (e.g., interruption as a result of action taken by the OLO, interruption due to transactions performed by or the operation of the router maintained and managed by the OLO, application incidents, etc.);
 - reasons attributable to third parties (e.g., break in a cable as a result of the actions of a third party);
 - force majeure;
- The time taken to resolve trouble tickets if the incidents are attributable to the OLO, such as the time Belgacom must wait for information from the OLO, to have access to the OLO site, for the OLO to be available, etc.;
- The time between the notification of a trouble ticket outside the intervention window and the start of the next intervention window;
- The period of the trouble ticket between the time the OLO is notified that the service is restored, and the time at which the OLO agrees to close the trouble ticket, or when the OLO is notified that the incident is not resolved.

13.5 How to calculate the site availability

Belgacom guarantees an Annual Site Availability for the SLA. This one is defined per OLO Site as 100% - A. A is equal to the net restoration time, expressed in hours. For Problem

Severity 1, the calculation is based on all the Trouble Tickets (repair ticket) taken into account during the measurement period, divided by 365 x 24.

The measurement period for the Annual Site Availability **shall start** on 1 January and end on 31 December:

- Sites that are set up during the measurement period shall be deemed to be 100% available -during the period prior to the installation;
- Sites that are closed during the measurement period shall be deemed to be 100% available during the period in which they are no longer in use;
- The same rules shall be applicable if, during the measurement period, the type of SLA is changed.
-

13.6 SLA Penalties

In case the SLA has been breached for a specific site, the customer can request penalties to be paid. Payment of these penalties is the only form of recoverable compensatory damages that a customer can get if the agreed upon service levels are not reached.

Penalties on the service restoration time for Severity 1 incidents			
Standard SLA	> 5 hrs => 5% of the monthly connectivity fee	> 10 hrs => 10% of the monthly connectivity fee	> 24 hrs => 25% of the monthly connectivity fee

Penalties on the availability level	
Standard SLA	< 99.90% => 1.5% of the annual connectivity fee
	< 99.70% => 5% of the annual connectivity fee

Payment of the penalties must always be requested by the Customer.

In case of failure to comply with the restoration time:

- The penalties are calculated as a percentage of the total monthly fee payable for the E-Line connectivity solution on the site concerned (access line & managed CPE).
- The penalties may not exceed 75% of the monthly fee for the E-Line connectivity solution (access line & managed CPE).
- Payment of the penalties can be claimed within three months of the end of the month in question.

In case of failure to comply with the availability level:

- The penalties are calculated as a percentage of the total annual fee payable for the E-Line connectivity solution on the site concerned (access line & managed CPE).
- The penalties may not exceed 5% of the annual fee for the E-Line connectivity solution (access line & managed CPE).
- Payment of the penalties can be claimed within three months of the end of the year in question

13.7 E-Troubleshooting

You can report a service disruption via the e-Troubleshooting application. Belgacom developed this to enable you to enter your information requests and incident reports via the Internet. On your trouble ticket you can always refer to your DSID (Data service Identifier), which you can find on the annex to the contract.

This online service allows you to monitor every aspect of your incident management. The service is available 24/7.

14. Securisation option for Partial Circuits and Backhails

14.1 Executive Summary

This document describes the packages of the different securisation which will be available on the access part of the Terminating Segment of Leased Line.

14.2 Standard equipment

- Mechanicals (rack, patch panel, interfaces...)
- Equipment (ADM-1, ADM-4, ADM-16 or VCTS)
- Connection to a fiber loop (if distance <300m)
- Fibre pose on private domain (ext. & int. cabling if distance < 50 meters) and cabling between the rack and the customer's application if those is located in the same room as the rack.

Version +

A securisation package called "Version+" is available in option. This package is composed by a 2nd equipment and a secured power supply.

		Standard	Premium	Excellence²
Standard equipment		X	X	X
2nd fiber introduction		-	O	X
Connection type	Shared	X	-	-
	Dedicated D1	-	X	-
	Dedicated D2	-	-	X
Version +		-	O	O
Service	High	X	X	X
	End-to-end	-	-	O

Table 14: Standard and Optional content of the packages

X: standard presenting package

² Only if BGC infrastructure available

O: Optional

If the customer wants effectively a customized installation, the account manager may present this following board:

(i.e.: the customer has already a secured power supply and wants only a 2nd equipment)

14.3 Securisation Package

The securisation offer will be presented to the customers as configurations with minimum options available. The purpose of this is that the securisation offer has to appear clear in the mind of the customer and standardizes the different processes (documentation, billing,...).

The securisation packages are available to secure the customer premise location or the point of presence of the operator between the customer end point and the first Belgacom building (LEX, AGE,...) from which the customer/ or the operator is connected.

In all cases, those securisation package won't be available in Belgacom site (co-mingling or physical colocation).

<u>SECURISATION STANDARD</u>		
<u>CONNECTION</u>	<u>SERIAL</u>	<u>OPTIONS</u>
SHARED RING	STANDARD EQUIPMENT	SECURED POWER SUPPLY

Table 15: Securisation Standard

<u>SECURISATION PREMIUM</u>		
<u>CONNECTION</u>	<u>SERIAL</u>	<u>OPTIONS</u>
DEDICATED RING (1LEX)	STANDARD EQUIPMENT	2 ND FIBER INTRODUCTION VERSION + SECURED POWER SUPPLY BATTERIES 2 ND EQUIPMENT

Table 16: Securisation Premium

<u>SECURISATION EXCELLENCE</u>		
<u>CONNECTION</u>	<u>SERIAL</u>	<u>OPTIONS</u>
DEDICATED RING (2LEX)	STANDARD EQUIPMENT 2 ND FIBER INTRODUCTION	VERSION + SECURED POWER SUPPLY 2 ND EQUIPMENT ADDITIONAL PROTECTION MECHANISM

Table 17: Securisation Excellence

14.4 Securisation services

Protection is based on SDH routing at cable level. The working and the protected paths can not use the same cable along the way.

Whenever failure occurs on the active optical path, the connection will be re-routed to the other optical path.

Following the option chosen by the customer, several options are available for the implementation of the second path :

1. using a second fiber intro (Premium package)
2. using a second intro and connected to another Belgacom building (Excellence package).

14.5 Package Pricing

Preliminary remark:

Belgacom Cosmopolitan Solution is only available under 300m from a fiber optic loop of a Telezone. For the distances > 300m, all the projects have to be studied case by case, and the customer will have to pay the entire connection cost to the Telezone (cost based).

In the following tables, a fiber introduction is an available³ pair of fiber optic provided by Belgacom into the building of the customer. A second introduction has to have a different path on the public and the private domain. This second path comes into the customer building by a different hole in the wall of the customer’s building.

Package 1: Standard

	Connection fee	
	Existing Fiber Introduction	Non Existing Fiber Introduction
Non-Recurent	0	2.478 €
Recurrent	0	0



³ An existing introduction with a sufficient number of pairs of fiber optic to realize the connection

Additional Costs		
	Non standard equipment & works	Secured power supply
Non-Recurrent	Upon quotation	2.478 €
Recurrent	0	49,58 €/month

Table 18: Package Standard prices

Package 2: Premium

Connection fee		
	Existing Fiber Introduction	Non Existing Fiber Introduction
Non-Recurrent	0	2.478 €
Recurrent	619,73 €	

Additional costs				
	Non standard equipment & works	Version +	2nd equipment	Secured power supply
Non-Recurrent	Upon quotation	4.957,87 €	3.718,40 €	2.478,94 €
Recurrent	0	Equipment based	Equipment based	49,58 €

2nd fiber introduction - Distance			
	0 - 100 m	100 -200 m	200 -300 m
Non-Recurrent	9.915,74 €	14.253,88 €	18.592,01 €
Recurrent	0	0	0

Table 19: Package Premium Prices per endpoint



Package 3: Excellence

Connection fee			
First fiber introduction exists			
Distance of the 2nd introduction			
	0 - 100 m	100 -200 m	200 -300 m
Non-recurrent	12.394,68 €	16.732,81 €	21.070,95 €
Recurrent	1.735,25 €		
No existing fiber introduction			
Distance of the 2nd introduction			
	0 - 100 m	100 -200 m	200 - 300 m
Non-recurrent	14.873,61 €	19.211,75 €	23.549,88 €
Recurrent	1.735,25 €		

Table 20: Package Excellence



Version + & 2nd equipment

Additional costs				
2 nd equipment				
	VCT-S	ADM-1	ADM-4	ADM-16
Non-recurrent	3.718,40 €			
Recurrent	322,26 €/month	570,16 €/month	1.561,73 €/month	Project based
Version + 2 nd equipment				
	VCT-S	ADM-1	ADM-4	ADM-16
Non-recurrent	4.957,87 €			
Recurrent	371,84 €/month	619,73 €/month	1.611,31 €/month	Project based

Table 21: Version + & 2nd equipment pricing

14.6 Securisation options

- 2nd equipment

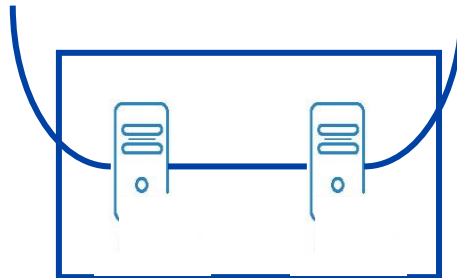

Figure 1: Securisation option Second ADM equipment

- 2nd introduction



Figure 2: Securisation Option Second fibre introduction

- Secured Power Supply

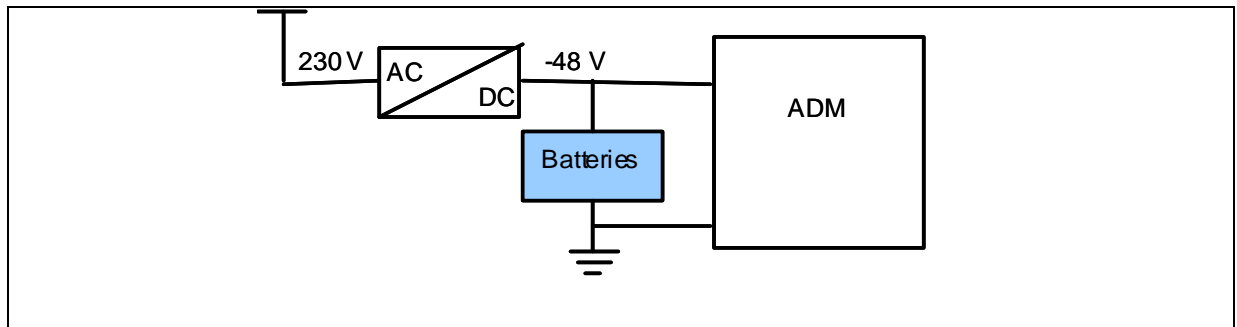

Figure 3: Securisation Option Secured Power Supply

Appendix 1 : List of the Area Access

A) List of BRIO Areas for Partial Circuits and Backhails

Access Area	Included Telephone Zones
Antwerpen	03
Bruxelles	02
Gent	09 (*), 052, 053, 054, 055
Kortrijk- Assebroek	050, 051, 056, 057, 058, 059
Liège	04 (*), 019, 080 (*), 085, 086, 087
Leuven- Hasselt	013, 014, 015, 016, 011, 012, 089
Mons- Charleroi:	065, 068, 069, 071, 060, 064, 067
Namur	081, 082, 083, 084, 061, 063, 010

(*) : for the sake of clarity, it is confirmed that where the present Reference Offer makes a reference to the zone codes indicated above, it should be noted that this is limited to the numbers which identify fixed network termination points. In particular, 09 and 04 are respectively limited to the number series 092, 093 and 042, 043. As far as the code 080 is concerned, the numbers starting with 0800 are excluded.

The names of the Access Areas are based upon the names of the cities (or agglomerations) in which the Area Access Points are located.

B) List of Service Areas for NGLL

a. Overview

5 Service Areas and 10 Service PoPs

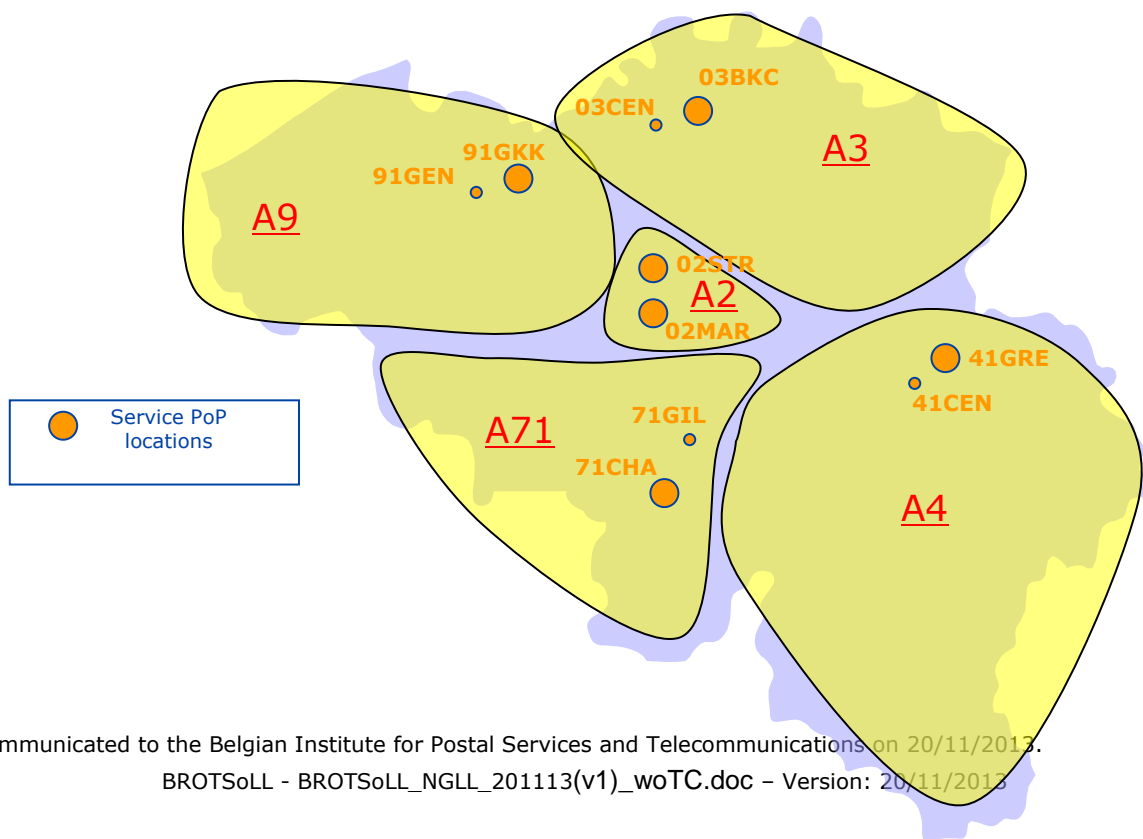

b. Definition of the Service Areas

Service Area Included Telephone Zones

A3:	03, 011, 012, 013, 014, 015, 016, 089
A2:	02
A4:	019, 04, 061, 063, 080, 081, 082, 083, 084, 085, 087
A71:	010, 060, 064, 065, 067, 068, 069, 071
A9:	050, 051, 052, 053, 054, 055, 056, 057, 058, 059, 09

- (*): For the sake of clarity, it is confirmed that the zone codes indicated above in the context of the present offer are limited to the numbers which identify fixed network termination points. In particular, 09 and 04 are respectively limited to the number series 092, 093 and 042, 043. As far as the code 080 is concerned, the numbers starting with 0800 are excluded.

c. List of Service PoPs

Area		City	Address	NCOW
A9	91GKK	Gent - Keizer Karel	Keizer Karelstraat 1	9265
A9	91GEN	GENT - CENTRUM	Sint Niklaasstraat 27	9223
A3	03CEN	Antwerpen - Centrum	Lange Nieuwstraat 106	3224
A3	03BKC	Antwerpen - Berchem	Karel Coggestraat 2	3227
A2	02MAR	Brussels - Marais	Rue du Marais - Broekstraat 72-74	2220
A2	02STR	Brussels - Paille	Rue Lebeau - Lebeustraet 2	2513
A71	71GIL	Charleroi - Gilly	Sentier de la Limite 80	7141
A71	71CHA	Charleroi - Centre	Rue de la science 2	7127
A4	41CEN	Liège - Centre	Rue de l'université 30	4223
A4	41GRE	Liège - Grétry	Rue d'Harscamp 17	4349

◆◆◆◆◆ End of document ◆◆◆◆◆

BROTSOLL

Annex 5

Technical specifications NGLL

Communicated to the Belgian Institute for Postal Services and Telecommunications on 20/11/2013.

BROTSOLL_Annex5_BROTSOLL_Annex5_NGLL_Technical_Specifications_201113(v1).docx - Version:
20/11/2013

Table of contents

CHAPTER 1 - INFORMATION ABOUT THIS DOCUMENT-----	3
1.1. SCOPE OF THIS DOCUMENT	3
1.2. ABBREVIATIONS	4
CHAPTER 2 - EXECUTIVE SUMMARY-----	5
2.1. NGLL SERVICE	5
CHAPTER 3 - NGLL BUILDING BLOCKS -----	6
3.1. CONNECTIVITY SERVICES	7
<i>MPLS TECHNOLOGY</i>	7
<i>ETHANE AREAS</i>	7
<i>ACCESS TECHNOLOGY</i>	9
<i>OVERALL SHAPING OF TRAFFIC:</i>	9
<i>ETHERNET ON FIBER ACCESS TECHNOLOGY</i>	10
<i>ETHERNET IN THE FIRST MILE (EFM) ACCESS TECHNOLOGY</i>	10
<i>CONFIGURING THE NGLL SERVICE WITH AGGREGATION POINT AND END-CUSTOMER SITES</i>	10
<i>VLAN LIMITATIONS:</i>	11
<i>PROTOCOL LIMITATIONS:</i>	12
3.2. CPE (CUSTOMER PREMISES EQUIPMENT)	13
3.3. QUALITY OF SERVICE (QoS)	14

Chapter 1 - Information about this document

1.1. Scope of this document

The purpose of this document is to describe the technical specifications of the Next Generation Leased Line service.

To allow the Operator to setup a service based on this service from Belgacom, this document is describing the interfaces.

The Operator willing to offer features which require other technical characteristics than those implemented and supported by Belgacom and described in the present reference offer, can implement them but without commitment of Belgacom on its correct functioning. Examples of such features are:

- Non-tested protocols or protocols not supported by Belgacom network equipments,
- Burst sizes, delay or jitter requirements, beyond the Belgacom retail applications.

Belgacom cannot guarantee, deliver support & be held liable regarding

- the correct functioning of such features in its network (at whatever time)
- the future evolution of other (supported or non-supported) features than those implemented and supported by Belgacom for its own services.

Any enumeration of supported or non-supported protocols or features listed in this document are not exhaustive and are based on the Belgacom best knowledge available at this moment.

1.2. Abbreviations

Abbreviation	Description
OAP	(OLO) Aggregation Point
APAL	(OLO) Aggregation Point Access Line
CBWFQ	Class-Based Weighted Fair Queuing
DS	Downstream
Gbps	Giga bit per sec (=1000Mbps)
HSCC	High Speed on Copper Concentrator
HSCR	High Speed on Copper Remote
Kbps	Kilo bit per sec
LAN	Local Access Network
LEX	Local Exchange
LTE	Line Termination Equipment
MAC@	MAC address
Mbps	Mega bit per sec (=1000Kbps)
MTU	Maximum Transmission Unit
NGLL	Next Generation Leased Line
OLO	Other Licensed Operator
p-bit	Priority bit
PoP	Point of Presence
QoS	Quality of Service
UNI	User Network Interface
US	Upstream
VLAN	Virtual LAN.

Chapter 2 - Executive Summary

2.1. NGLL service

Belgacom NGLL is an Ethernet (Layer2) connectivity service; it is based on Ethernet over MPLS technology and can be accessed via Ethernet over copper (Ethernet in the First Mile = EFM) or Ethernet over fiber.

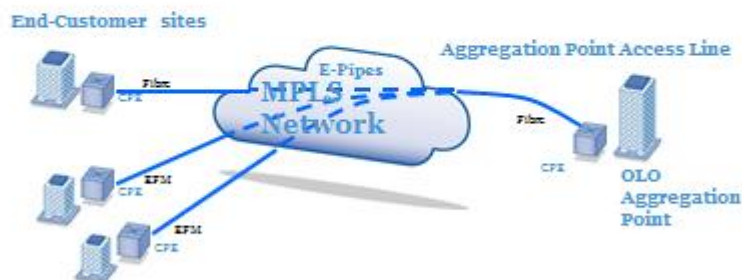

Figure 1: NGLL configuration

Chapter 3 - NGLL building blocks

The NGLL solutions are based on the following service building blocks:

- Connectivity services
 - CPE (Customer Premises Equipment) services
 - Class of Service/Quality of Service
-

3.1. Connectivity services

MPLS technology

The network is based on the Belgacom MPLS network ETHANE.

ETHANE areas

There are 5 Service areas in the Belgian Belgacom MPLS network, called ETHANE.

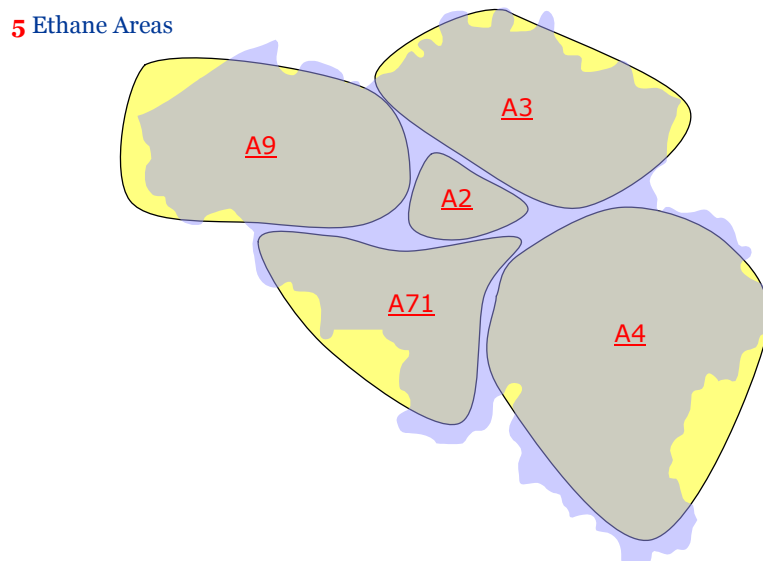

Figure 2: Services Areas

Per Area there are 2 Service Pops. The LEXs are interconnected by Ethernet Rings to the 2 Service Pops.

The OLO Aggregation Point is connected to the Service POP of an Ethane AREA (not to a LEX), via an “Aggregation Point Access Line” (APAL) and shall be geographically located in the same ETHANE AREA

End-user sites will be connected to the LEXs of one or more ETHANE AREAs.

Next Generation Leased Line : a NGLL is connecting **one** end-Customer site to **one** OLO Aggregation Point, **both located** in the same ETHANE AREA, using one e-pipe per End-Customer site.

An OLO having one or more End-Customer Sites in a given Area, must have at least 1 Aggregation Point connected to a POP of this Area.

An OLO having End-Customer Sites in more than one Ethane Area, must have also more than one OLO Aggregation Point.

Aggregation point must be in the same Service area as End-customer sites

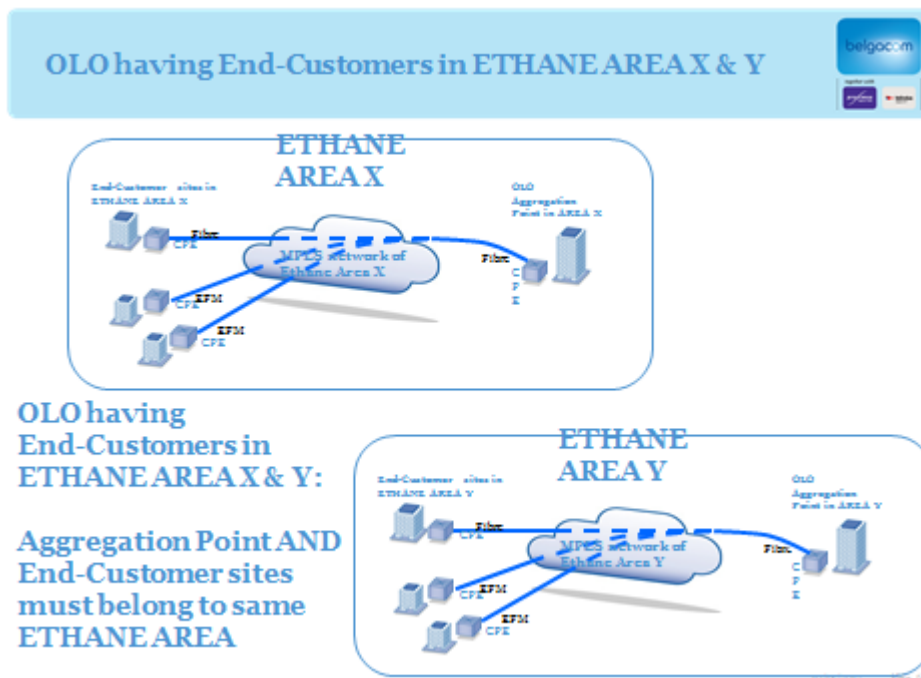

Figure 3: Aggregation points in the same area as End-customer site

In the NGLL solution, traffic will always flow between an End-Customer Site and the Aggregation Point, never between End-Customer Site and End-Customer Site (no any-to-any connectivity).

The Aggregation Point can be:

- An OLO POP: Customer Sited
- A colocation: BGC sited

The End-Customer site can be:

- An OLO POP: Customer Sited
- An end-user site : Customer Sited

Access Technology

End-customer Site:

The Access Technology is the technology used between the Ethane node in the LEX up to the LTE at End-Customer Site.

The choice of the Access Technology, Ethernet over copper (EFM) or Ethernet over Fiber, depends on bandwidth ordered, availability in the network and location in the network.

Olo Aggregation Point:

The Access Technology is the technology used between the Ethane node in the Service POP up to the LTE at OLO Aggregation Point. Always a Fibre link (one single link) is used.

Overall shaping of traffic:

The overall Ethernet flows on End-Customer and Aggregation Point access technology are shaped to a value, ordered by the OLO, and further called the bandwidth profile.

- 2Mbps to 10Mbps: 2Mbps steps (2,4,6,8,10)
- 10Mbps to 100Mbps: 10Mbps steps (10,...90, 100)
- 100Mbps to 1Gbps: steps of 100Mbps

There is no limitation to the data volume that can be transferred.

Ethernet on fiber access technology

The Ethernet on fiber access is a high-speed data transfer service, offering interface speed options from 10Mbps to 1Gbps between the site and the Ethane network, regardless of the distance between them. Traffic shaping increases granularity, allowing for bandwidth profiles from 2M up to 1G in smaller bandwidth steps.

The Ethernet access service is based on Belgacom's fiber optic infrastructure. This is a comprehensive service which includes the network infrastructure.

Ethernet in the First Mile (EFM) access technology

At the End-Customer Site, a High Speed on Copper End-Customer (HSCR) device is connected through one or more copper pair(s) (maximum 8) to a High Speed on Copper Concentrator (HSCC) in the closest LEX. From here, traffic is transported to the Ethane MPLS platform.

The availability of such service is determined by:

- the attenuation of the copper pairs (linked to the distance)
- the number of copper pairs available on the site

Available bandwidth profiles are 2, 4, 6, 8, 10 or 20 Mbps.

Configuring the NGLL service with Aggregation Point and End-Customer Sites

In the following paragraphs, a distinction will be made between Aggregation Point (AP) and End-Customer Sites.

A start configuration consists of an OLO Aggregation Point and one or more End-Customer Sites. Afterwards, adding End-Customer Sites to this configuration is relatively straightforward, with only the additional sites to be ordered and provisioned. The OLO defines if and when the bandwidth of the Aggregation Point needs to be adapted, taking into account the required service quality and the estimated implementation delay.

AGGREGATION POINT:

The OLO Aggregation Point is connected to a ETHANE Service Pop using a Gigabit Ethernet access line over fiber optic, called Aggregation Point Access Line (APAL).

The traffic of all End-Customer Sites will be delivered on the OLO Aggregation Point Access Line, which is terminated in a LTE and further is connected to a Belgacom managed CPE switch. The physical interface to the OLO, on the CPE switch, can be copper (=default) or fiber and must work in QinQ.

END-CUSTOMER SITES:

The End-Customer Sites can be connected via Ethernet over copper (EFM) or Ethernet over fiber, both Access Technologies are terminated by a LTE and further connected to a BGC managed CPE switch. The physical interface to the End-Customer, on the CPE switch, can be copper (=default) or fiber and must work in dot1Q.

NGLL presents an Ethernet interface to OLOs, simplifying the LAN/WAN boundary for Service Providers and OLOs, and enabling rapid and flexible service provisioning, because the service bandwidth is not directly tied to the physical interface.

A unique VLAN-id identifies the End-Customer Site at the Aggregation Point level (example in figure: site id 80 and S-tag 80). This is the so-called S-tag or outer tag at the Aggregation Point level. This solution is limited to 1000 VLANs (S-Tags) at the Aggregation Point level.

The End-Customer Site works in dot1Q and the Vlan tags (VLAN ids and p-bit) sent by a specific End-Customer site (example in figure 4: VLANs 30 & 50) are received unchanged at the OLO Aggregation Point switch as C-tags, under the S-tag, identifying the specific End-Customer site (example in figure 4: 80.30 and 80.50). The Aggregation Point device of the OLO must work in QinQ

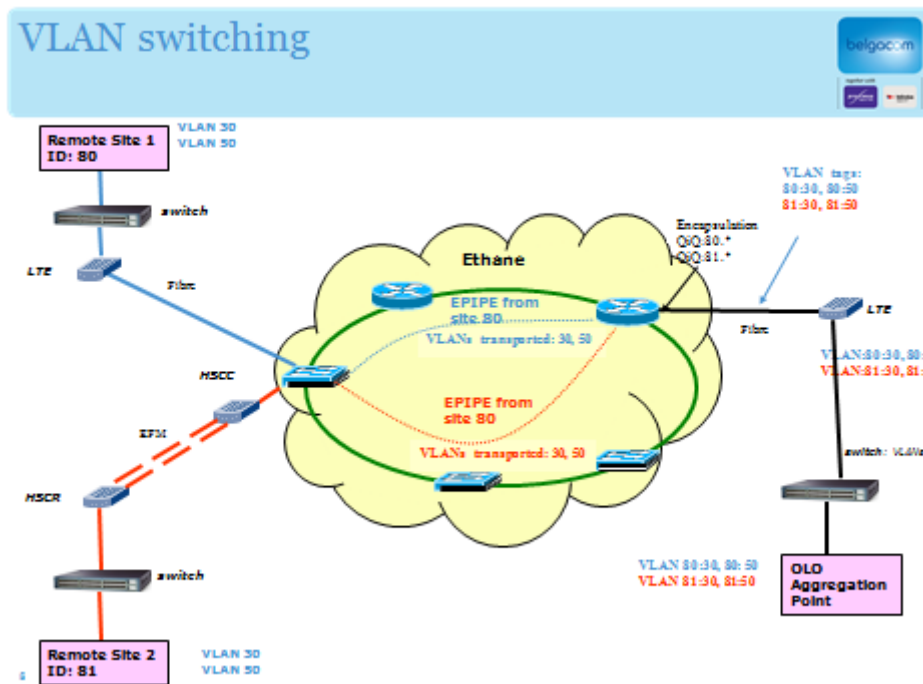

Figure 4: VLANs at End-Customer Site vs at OLO Aggregation Point

VLAN limitations:

Max 1000 S-tags @ Aggregation Point in range [2,4000], to be allocated by the OLO and configured by BGC and OLO.

Max 1000 C-tags @ End-Customer site in range [2,4000], to be allocated by the OLO and configured by BGC (in CPE switch) and OLO. VLAN id 999, 1002, 1003, 1004, 1005 and > 4000 are reserved and cannot be used by the End-customer.

Protocol limitations:

The service is intended for transport of IP packets by Ethernet frames (IPoE). Some protocols outside of this IPoE framework do not transparently pass.

Here is a list with known protocols for which Belgacom does not guarantee the correct functioning.

Layer 2 Control protocols and other L2 protocols:

Mac address	Application	Reference
01-80-C2-00-00-01	Pause frames	IEEE 802.3x
01-80-C2-00-00-02	Slow protocol (LACP IEEE 802.3ad, LAMP, EFM IEEE 802.3ah OAMPDU)	IEEE 802.3
01-80-C2-00-00-03	EAP over LANs	IEEE 802.1x
01-80-C2-00-00-30 To 01-80-C2-00-00-3F	CFM	IEEE 802.1ag and ITU Y.1731.

Cisco L2 Control protocols:

Destination Multicast Mac address	Application
01-00-0C-CC-CC-CC	Unidirectional Link Detection (UDLD)
01-00-0C-CC-CC-CC	Cisco Discovery Protocol (CDP)
01-00-0C-CC-CC-CC	VLAN Trunking (VTP)

The lists provided here above are indicative and non-exhaustive.

OLO has the opportunity to request on a project mode basis for ad hoc testing to check the transparency of any specific protocol in the context of NGLL.

Mac learning:

Because of MAC learning in several equipments in the NGLL configuration, the number of MAC addresses shall be limited to 500 per End-customer site and to 8000 per Aggregation point.

3.2. CPE (Customer Premises Equipment)

Demarcation point

The connectivity access lines are installed & configured by Belgacom, including the “demarcation” CPE, typically a switch. The OLO can install and configure his own CPE (e.g.: an IPVPN router) behind the Belgacom switch.

- The current demarcation CPE on the Aggregation Point and End-Customer Sites is a Belgacom-managed switch.
- Traffic is delivered to the end-customer via one customer-facing port (10BaseT RJ45, or 100BaseT RJ45, or 1000BaseT RJ45), or optionally optical LC connector.
- Ethernet MTU size: 1564 octets at End-User Demarcation point, including the C-tag VLAN.

In this document, the MTU size is defined as the “Ethernet MTU size” and the number 1564 octets is including following fields (cfr. Figure 3-3 from IEEE802.3-2005):

- | | |
|---------------------------|--|
| ○ Destination Address: | 6 octets |
| ○ Source Address: | 6 octets |
| ○ Qtag (is Ctag): | 4 octets |
| ○ Mac Client Length/Type: | 2 octets |
| ○ MAC Client Data +PAD: | 1542 octets (> 1500 octets in IEEE 802.3-2005) |
| ○ Frame Check Sequence: | 4 octets |
| <hr/> | |
| ○ Total: | 1564 octets |

Note that one C-tag at End-user demarcation point is obligatory for indicating the user priority (also for po).

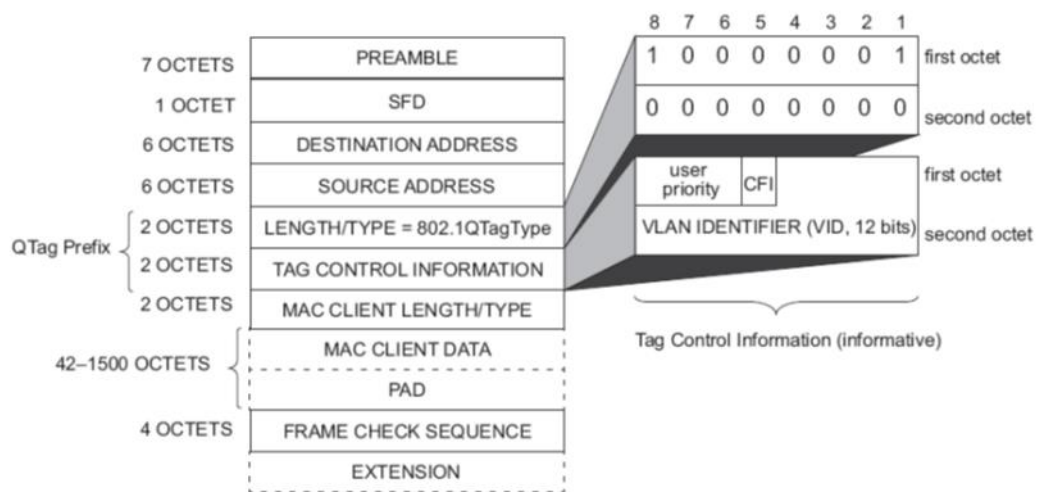

Figure 3-3—Tagged MAC frame format

Figure 5: Tagged MAC frame format

CPE synchronization:

No clock reference is provided by BGC.

3.3. Quality of Service (QoS)

The Quality of Service (QoS) classes available, are called:

- Best effort
- Business data
- Voice

The OLO must make sure p-bit values are 5, 3 or 0 in the traffic sent to Belgacom. Other p-bit marked Ethernet Frames (p1,p2,p4,p6,p7) are treated as “best effort” in the MPLS network.

Shaping of the overall traffic per site (End-Customer site and Aggregation Point) is performed in two steps per End-Customer site and per OLO Aggregation Point:

- Step 1: Shaping to “bandwidth profile” of the site, eg 500Mbps on fibre. (see higher)
- Step 2: Policing of the Voice (p5 marked) traffic : 0%, 25%, 50% or 75% of the access bandwidth profile.

The service Quality P=5 has the highest priority in the network and is also designed to offer better performance for jitter and delay sensitive traffic (eg. Voice and real-time traffic). The traffic sent tagged with P=5 should take into account that this service quality is less tolerant to bursts of data. It is advised to send traffic with an appropriate shaping and small packet size to avoid packet loss.

IMPORTANT:

Qos is offered only on p-bit:

P0: Best effort

P3: Business Data

P5: Voice

◆◆◆◆◆ End of document ◆◆◆◆◆